

# PUBLIC WORKS MANUAL

PHENIX CITY, ALABAMA



JANUARY 2022

DRAFT



# TABLE OF CONTENTS

<b>1.0 GENERAL INFORMATION .....</b>	<b>1-1</b>
<b>1.1 INTRODUCTION.....</b>	<b>1-1</b>
1.1.1 Purpose of the Manual .....	1-1
1.1.2 Use of the Manual.....	1-1
1.1.3 Authority (Governing Regulations) .....	1-2
<b>1.2 ABBREVIATIONS, ACRONYMS, AND DEFINITIONS .....</b>	<b>1-2</b>
1.2.1 Purpose .....	1-2
1.2.2 Word Usage.....	1-2
1.2.3 Abbreviations and Acronyms.....	1-2
1.2.4 Definitions.....	1-4
<b>1.3 DEVELOPMENT PROCESS.....</b>	<b>1-19</b>
1.3.1 Overview .....	1-19
1.3.2 Subdivision and Residential Projects .....	1-19
1.3.2.1 Pre-Application .....	1-19
1.3.2.2 Preliminary Plat.....	1-19
1.3.2.3 Construction Plans .....	1-20
1.3.2.4 Final Plat and As-Built Survey .....	1-20
1.3.2.5 Action on Final Plat .....	1-20
1.3.2.6 Administrative Subdivision .....	1-21
1.3.3 Site Development Projects .....	1-21
1.3.3.1 Permitted Uses.....	1-21
1.3.3.2 Conditional Uses .....	1-21
1.3.3.3 Traffic Impact Study.....	1-22
1.3.3.4 Pre-Application .....	1-22
1.3.3.5 Construction Plans .....	1-22
1.3.4 Rezoning.....	1-22
1.3.5 Permits.....	1-23
1.3.5.1 Land Disturbance Permit .....	1-23
1.3.5.2 Burn Permit.....	1-24
1.3.5.3 Permit to Construct a Turnout to Provide Access to a City Street (Commercial and Residential).....	1-24
1.3.5.4 Building Permit.....	1-24
1.3.5.5 Electrical Permit .....	1-24
1.3.5.6 Plumbing Permit .....	1-24
1.3.5.7 Gas Fitting Permit .....	1-24
1.3.5.8 HVAC / Mechanical Permit .....	1-25
1.3.5.9 Certificate of Occupancy.....	1-25

## TABLE OF CONTENTS

1.3.5.10	Swimming Pool Permit.....	1-25
1.3.5.11	Demolition Permit.....	1-25
1.3.5.12	Sign Permit.....	1-25
1.3.5.13	House Moving Permit.....	1-25
1.3.5.14	Food Service Establishment Permit.....	1-25
1.3.5.15	Other Permits.....	1-26
<b>1.4</b>	<b>EASEMENTS.....</b>	<b>1-26</b>
1.4.1	Overview.....	1-26
1.4.2	Dimensions.....	1-26
1.4.3	Obstructions and Access.....	1-26
1.4.4	Service Activations.....	1-27
1.4.5	Dedications.....	1-27
1.4.5.1	Dedication by Document.....	1-27
1.4.5.2	Dedication by Plat.....	1-28
<b>1.5</b>	<b>WARRANTY PERIOD.....</b>	<b>1-28</b>
<b>1.6</b>	<b>UPDATES AND WAIVERS.....</b>	<b>1-29</b>
1.6.1	Manual Updates.....	1-29
1.6.2	Project Specific Waivers.....	1-29
Appendix 1A.	Petition for Administrative Subdivision.....	1-32
Appendix 1B.	Petition for Subdivision.....	1-36
Appendix 1C.	Petition for Conditional Use.....	1-44
Appendix 1D.	Land Disturbance Permit Application and Checklist.....	1-46
Appendix 1E.	Petition for Rezone.....	1-51
Appendix 1F.	Request for Waiver.....	1-55
<b>2.0</b>	<b>TRAFFIC SIGNAL DESIGN.....</b>	<b>2-1</b>
<b>2.1</b>	<b>SIGNAL DESIGN ELEMENTS.....</b>	<b>2-1</b>
2.1.1	Signal Heads.....	2-1
2.1.2	Signal Supports.....	2-1
2.1.3	Cabinet and Controller Equipment.....	2-2
2.1.4	Communications.....	2-2
2.1.4.1	Extension of Existing System.....	2-2
2.1.4.2	New System Implementation.....	2-2
2.1.5	Signal Wiring, Conduit, and Junction Boxes.....	2-3
2.1.6	Power Supply.....	2-3
2.1.7	Vehicle Detection.....	2-3
2.1.7.1	Inductive Loops.....	2-3

## TABLE OF CONTENTS

2.1.7.1.1	Stop Line Detection.....	2-4
2.1.7.1.2	Advanced Detection.....	2-4
2.1.7.2	Video/Radar Detection .....	2-5
2.1.8	Railroad Pre-Emption.....	2-5
2.1.9	Emergency Pre-Emption .....	2-5
2.1.10	Intersection Signage.....	2-6
2.1.11	Pedestrian Signal.....	2-6
2.1.11.1	Warrants .....	2-6
2.1.11.2	Sequence.....	2-7
2.1.11.3	Timing.....	2-7
2.1.12	Intersection Lighting .....	2-7
<b>2.2</b>	<b>SIGNAL TIMING .....</b>	<b>2-7</b>
2.2.1	Phasing.....	2-8
2.2.2	Cycle Lengths .....	2-8
2.2.3	Actuated Timing Parameters .....	2-8
2.2.4	Signal Timing Plans.....	2-8
<b>2.3</b>	<b>PLANS PRODUCTION .....</b>	<b>2-8</b>
2.3.1	Traffic Signal Notes .....	2-9
2.3.2	Signal Plan .....	2-9
2.3.2.1	Installation Notes.....	2-9
2.3.2.2	Signal Head Displays .....	2-9
2.3.2.3	Signage Displays.....	2-9
2.3.2.4	Pre-Emption Phasing Diagram .....	2-10
2.3.2.5	Signal Sequence/Timing Chart .....	2-10
2.3.2.6	Conflict Monitor Chart .....	2-10
2.3.2.7	Wiring Diagram and Table .....	2-10
2.3.2.8	Materials List.....	2-10
2.3.3	Details and Standard Drawings.....	2-11
2.3.4	Communication Plan.....	2-11
2.3.5	Construction.....	2-11
Appendix 2A. Decorative Signal Pole Assembly .....		2-13
<b>3.0</b>	<b>TRAFFIC IMPACT STUDIES.....</b>	<b>3-1</b>
<b>3.1</b>	<b>TRAFFIC IMPACT STUDY REQUIREMENTS.....</b>	<b>3-1</b>
3.1.1	General.....	3-1
3.1.2	Applicability.....	3-1
3.1.3	Applicant Responsibility.....	3-2

**TABLE OF CONTENTS**

3.1.4 Capacity and Safety Issues .....3-2

    3.1.4.1 Vehicular Traffic Improvements .....3-3

    3.1.4.2 Pedestrian Traffic Considerations and Improvements .....3-3

    3.1.4.3 Bicycle Traffic Improvements .....3-3

**3.2 TRAFFIC IMPACT STUDY PROCEDURES AND CRITERIA .....3-3**

    3.2.1 Scoping Meeting / Telephone Conference .....3-3

        3.2.1.1 Purpose .....3-3

        3.2.1.2 Meeting / Telephone Conference Setup and Content .....3-4

        3.2.1.3 Results of Meeting / Telephone Conference .....3-4

    3.2.2 Evaluation Elements .....3-4

    3.2.3 Roadway Traffic Volumes / Traffic Counts .....3-5

    3.2.4 Intersection and Approach Level of Service .....3-6

    3.2.5 Trip Generation Rate.....3-6

    3.2.6 Preliminary Land Use Assumptions .....3-6

    3.2.7 Trip Generation Table .....3-6

    3.2.8 Trip Distribution .....3-7

    3.2.9 Intersection Delay .....3-7

    3.2.10 Driveway Access.....3-7

    3.2.11 Traffic Signals .....3-8

    3.2.12 Mitigation Measures.....3-9

    3.2.13 Traffic Signal Operations Improvements .....3-9

    3.2.14 Geometric Improvements, Street Widening, and Other Physical  
    Improvements.....3-9

**3.3 TRAFFIC IMPACT STUDY REPORT CONCLUSIONS ..... 3-10**

    3.3.1 Geometric Improvements.....3-10

    3.3.2 Responsibility .....3-10

**3.4 TRAFFIC IMPACT STUDY REPORT OUTLINE..... 3-10**

    3.4.1 Introduction .....3-10

    3.4.2 Proposed Development .....3-10

    3.4.3 Existing Traffic Conditions.....3-10

    3.4.4 Future Traffic Conditions .....3-11

    3.4.5 Summary and Conclusions.....3-11

**4.0 ROADWAY AND PARKING DESIGN .....4-1**

**4.1 INTRODUCTION.....4-1**

**4.2 ROADWAY DESIGN ELEMENTS.....4-1**

    4.2.1 Design Criteria.....4-1

---

## TABLE OF CONTENTS

4.2.1.1	Design Controls and Criteria .....	4-1
4.2.1.1.1	Street and Road Classifications.....	4-2
4.2.1.1.2	Design Vehicles .....	4-2
4.2.1.2	Design Speed.....	4-3
4.2.1.3	Horizontal Alignment .....	4-3
4.2.1.4	Vertical Alignment .....	4-4
4.2.1.4.1	Vertical Curves / Sight Distance.....	4-4
4.2.1.4.2	Vertical Grade .....	4-4
4.2.1.4.3	Vertical Clearance .....	4-4
4.2.1.5	Typical Street Section.....	4-4
4.2.1.5.1	Streets .....	4-5
4.2.1.5.2	Sidewalks.....	4-6
4.2.1.5.2.1	Design Criteria.....	4-7
4.2.1.5.2.2	Sidewalk Location .....	4-8
4.2.1.5.2.3	Sidewalk Installation .....	4-9
4.2.1.5.2.4	Inspections .....	4-9
4.2.1.5.2.5	Exceptions .....	4-10
4.2.1.5.2.6	Requests for Sidewalks .....	4-10
4.2.1.6	Clear Zone .....	4-11
4.2.1.7	Driveways.....	4-11
4.2.1.7.1	Design Criteria - Residential.....	4-12
4.2.1.7.2	Design Criteria - Commercial .....	4-12
4.2.1.7.3	Driveway Location.....	4-14
4.2.1.7.4	Driveway Spacing.....	4-15
4.2.1.7.5	Driveway Alignment.....	4-17
4.2.1.7.6	Shared Driveways.....	4-17
4.2.1.8	Private Streets.....	4-18
4.2.1.9	Greenways .....	4-18
4.2.1.10	Bicycle and Pedestrian Facilities .....	4-19
4.2.1.10.1	Shared Use Paths .....	4-20
4.2.1.10.2	Bicycle Lanes .....	4-21
4.2.1.10.3	Shared Roadway .....	4-21
4.2.1.11	Cul-de-sacs .....	4-22
4.2.1.12	Frontage Road / Service Drive .....	4-22
4.2.1.13	Median Openings.....	4-23
4.2.1.14	Guardrails.....	4-23
4.2.1.14.1	Embankment Criteria.....	4-23
4.2.1.14.2	Fixed Object Criteria .....	4-23
4.2.1.14.3	Non-traversable Hazard Criteria.....	4-24
4.2.1.14.4	Bridge Rail Ends, Transitions, and End Treatment Criteria.....	4-25
4.2.1.14.5	Ditch Section Criteria .....	4-25
4.2.1.15	Permanent Barricades .....	4-25

## TABLE OF CONTENTS

4.2.1.16	Storm Drainage Control .....	4-25
4.2.1.17	Transit Stops .....	4-25
<b>4.3</b>	<b>INTERSECTION DESIGN ELEMENTS .....</b>	<b>4-25</b>
4.3.1	Design Criteria.....	4-25
4.3.1.1	Angle of Intersection.....	4-25
4.3.1.2	Development Entrances.....	4-26
4.3.1.2.1	Signs .....	4-26
4.3.1.2.2	Landscaping.....	4-26
4.3.1.2.3	Islands .....	4-26
4.3.1.2.4	Gates .....	4-27
4.3.1.2.5	Water and Sanitary Infrastructure.....	4-27
4.3.1.3	Sight Distance.....	4-27
4.3.1.4	Roundabouts.....	4-30
4.3.1.4.1	Geometric Characteristics.....	4-31
4.3.1.4.2	Sight Triangle .....	4-31
4.3.1.4.3	Landscaping.....	4-31
4.3.2	Left Turn Lane Warrants at Unsignalized Intersections.....	4-32
4.3.3	Left Turn Lane Warrants at Signalized Intersections.....	4-35
4.3.4	Right Turn Lane Warrants .....	4-35
4.3.5	Deceleration Lanes and Tapers.....	4-36
4.3.6	Left Turn Lanes on Divided Roadways.....	4-38
<b>4.4</b>	<b>DESIGN OF PAVEMENTS .....</b>	<b>4-38</b>
4.4.1	Design Criteria.....	4-38
4.4.1.1	New Construction .....	4-38
4.4.1.1.1	Local Streets.....	4-38
4.4.1.1.2	Arterials and All Collectors.....	4-39
4.4.1.2	Pavement Repairs/Retrofit .....	4-39
4.4.1.3	Subgrade Construction .....	4-40
4.4.1.4	Base.....	4-40
4.4.2	Maintenance Process.....	4-40
<b>4.5</b>	<b>DESIGN OF UTILITIES IN STREET RIGHT-OF-WAY.....</b>	<b>4-41</b>
4.5.1	Permits.....	4-41
4.5.1.1	Warranty and Permittee Responsibilities.....	4-42
4.5.2	Design Criteria.....	4-42
4.5.2.1	General Locations .....	4-42
4.5.2.2	General Requirements.....	4-44
4.5.2.2.1	Electric Installations.....	4-44
4.5.2.2.2	Pipe Cover .....	4-45
4.5.2.2.3	Excavation and Backfill Requirements.....	4-45
4.5.2.2.4	Open Cut Installation .....	4-46
4.5.2.2.4.1	Asphalt Cuts .....	4-46

## TABLE OF CONTENTS

4.5.2.2.4.2	Concrete Cuts.....	4-47
4.5.2.2.4.3	Installation in Unpaved Streets.....	4-47
4.5.2.2.4.4	Asphalt Patches.....	4-47
4.5.2.2.4.5	Resurfacing/Permanent Patches .....	4-48
4.5.2.2.4.6	Driveway Replacement .....	4-49
4.5.2.2.4.6.1	Concrete Residential Driveway.....	4-49
4.5.2.2.4.6.2	Concrete Commercial Driveway.....	4-49
4.5.2.2.4.6.3	Asphalt Driveway .....	4-49
4.5.2.2.4.6.4	Replacement .....	4-50
4.5.2.2.5	Bore Installation.....	4-50
4.5.3	Maintenance Process.....	4-51
<b>4.6</b>	<b>STREET LIGHTING .....</b>	<b>4-51</b>
4.6.1	Requirements.....	4-51
4.6.2	Fixture Types.....	4-51
4.6.2.1	Standard Cobra Head Fixtures .....	4-52
4.6.2.2	Standard Decorative Fixtures.....	4-52
4.6.2.3	Specialized Decorative Fixtures .....	4-52
4.6.2.4	Decorative Pedestrian Lighting .....	4-52
<b>4.7</b>	<b>SIGNING AND PAVEMENT MARKINGS .....</b>	<b>4-54</b>
4.7.1	Application Process.....	4-54
4.7.1.1	New Developments.....	4-54
4.7.1.2	Existing Developments.....	4-55
4.7.2	Requirements.....	4-55
4.7.2.1	Street Name Signs .....	4-55
4.7.2.2	Regulatory Signs.....	4-56
4.7.3	Maintenance Process.....	4-56
4.7.3.1	Replacement for Street Name or Regulatory Signs .....	4-56
4.7.3.2	Replacement for Decorative Signs.....	4-56
<b>4.8</b>	<b>RIGHT-OF-WAY PLANTING.....</b>	<b>4-57</b>
4.8.1	Application Process.....	4-57
4.8.2	Design Criteria.....	4-58
4.8.2.1	Visibility at Intersections.....	4-58
4.8.2.2	Right-of-Way Trees .....	4-59
4.8.2.3	Irrigation.....	4-59
4.8.3	Maintenance Process.....	4-59
<b>4.9</b>	<b>ACCESS MANAGEMENT AND COORDINATION .....</b>	<b>4-59</b>
4.9.1	Application Process.....	4-60

**TABLE OF CONTENTS**

4.9.2 Design Criteria..... 4-61

**4.10 OFF-STREET PARKING..... 4-61**

**4.11 TRAFFIC CALMING (NEW DEVELOPMENTS ONLY)..... 4-62**

4.11.1 Existing Condition Analysis ..... 4-62

4.11.1.1 Minimum Vehicular Volume ..... 4-63

4.11.1.2 Speed ..... 4-63

4.11.1.3 Cut Through Traffic ..... 4-63

4.11.1.4 Crashes ..... 4-64

4.11.1.5 Street Grades and Alignment..... 4-64

4.11.1.6 Transit, School, and Emergency Routes..... 4-64

4.11.2 Results of Traffic Calming Analysis ..... 4-64

4.11.3 Neighborhood Petitions and Cost Share..... 4-65

4.11.4 Implementation ..... 4-66

4.11.4.1 Material Submittal ..... 4-67

4.11.4.2 Test Requirements ..... 4-67

4.11.4.3 Inspection..... 4-67

4.11.5 Maintenance ..... 4-67

4.11.6 Review and Analysis of Applied Solutions ..... 4-67

**4.12 CONSTRUCTION ..... 4-68**

Appendix 4A. Street Classifications..... 4-70

Appendix 4B. Standard Drawings and Details..... 4-98

Appendix 4C. Request for Sidewalk Construction Form ..... 4-108

Appendix 4D. Permit to Construct a Turnout to Provide Access to a City Street  
(Residential) ..... 4-110

Appendix 4E. Permit to Construct a Turnout to Provide Access to a City Street  
(Commercial)..... 4-114

Appendix 4F. Left/Right Turn Lane Quick Guide..... 4-118

Appendix 4G. Application for Installation of Underground Utility Permit..... 4-121

Appendix 4H. Traffic Sign Request Form (New Development) ..... 4-124

Appendix 4I. Traffic Sign Request Form (Existing Development) ..... 4-126

Appendix 4J. Descriptions of Stage 2 Traffic Calming Measures ..... 4-128

Appendix 4K. Traffic Calming Petition Package ..... 4-133

**5.0 GEOTECHNICAL ..... 5-1**

**5.1 INTRODUCTION..... 5-1**

**5.2 OVERVIEW OF GEOTECHNICAL INVESTIGATIONS ..... 5-1**



<b>5.3 EARTHWORK.....</b>	<b>5-2</b>
5.3.1 Earthwork Investigation.....	5-2
5.3.2 Embankment Fill .....	5-3
5.3.3 Rock Excavation and Blasting.....	5-4
5.3.4 Slopes.....	5-4
<b>5.4 RETAINING WALLS .....</b>	<b>5-4</b>
5.4.1 Overview .....	5-4
5.4.2 Acceptable Wall Types .....	5-5
5.4.3 Geotechnical Investigation .....	5-5
5.4.4 Drainage and Backfill Requirements.....	5-6
5.4.5 Stability Requirements.....	5-6
5.4.5.1 External and Internal Stability of Fill Walls.....	5-6
5.4.5.2 Deformations .....	5-7
5.4.5.3 Global Stability .....	5-7
5.4.6 Documentation and Notification Requirements .....	5-8
<b>5.5 DAM DESIGN GUIDELINES .....</b>	<b>5-8</b>
5.5.1 Overview .....	5-8
5.5.2 Definition of a Dam .....	5-8
5.5.3 Classes of Dams.....	5-9
5.5.4 Geotechnical Investigation .....	5-9
5.5.5 Design and Safety Requirements.....	5-10
5.5.6 Documentation and Notification Requirements .....	5-11
5.5.7 Types of Inspections .....	5-11
5.5.8 Inspection Guidelines.....	5-12
5.5.9 Emergency Action Plan .....	5-12
Appendix 5A. Visual Inspection Checklist.....	5-15
<b>6.0 DRAINAGE .....</b>	<b>6-1</b>
<b>6.1 INTRODUCTION.....</b>	<b>6-1</b>
<b>6.2 DESIGN ELEMENTS .....</b>	<b>6-1</b>
6.2.1 Stormwater Hydrology.....	6-1
6.2.2 Storm Drain Design .....	6-3
6.2.3 Surface Drainage.....	6-3
6.2.4 Detention and Retention Facilities .....	6-5
6.2.5 BMPs for Control of Pollutants .....	6-7
6.2.6 Erosion and Sediment Control.....	6-7

<b>6.3</b>	<b>MATERIAL REQUIREMENTS .....</b>	<b>6-7</b>
<b>6.4</b>	<b>SUBMITTAL REQUIREMENTS .....</b>	<b>6-7</b>
6.4.1	Plan Requirements.....	6-7
6.4.2	Application Requirements .....	6-8
6.4.3	Bonds and Fees .....	6-8
<b>6.5</b>	<b>MAINTENANCE AND ONGOING INSPECTION REQUIREMENTS .....</b>	<b>6-9</b>
Appendix 6A.	Drainage Details.....	6-11
Appendix 6B.	Stormwater Storage Facility Operation and Maintenance Agreement (Lee County).....	6-25
Appendix 6C.	Subdivision Stormwater Storage Facility Operation and Maintenance Agreement (Lee County).....	6-28
Appendix 6D.	Stormwater Storage Facility Operation and Maintenance Agreements (Russell County) .....	6-33
Appendix 6E.	Subdivision Stormwater Storage Facility Operation and Maintenance Agreement (Russell County) .....	6-36
Appendix 6F.	Stormwater Storage Facility Final Certification Form.....	6-41
<b>7.0</b>	<b>UTILITIES (POTABLE WATER AND SANITARY SEWER).....</b>	<b>7-1</b>
<b>7.1</b>	<b>GENERAL.....</b>	<b>7-1</b>
7.1.1	Potable Water and Sanitary Sewer Locations .....	7-1
7.1.2	Required Pre-Development Meeting.....	7-1
7.1.3	City Acceptance of Potable Water and Sanitary Sewer Infrastructure .....	7-1
<b>7.2</b>	<b>POTABLE WATER.....</b>	<b>7-2</b>
7.2.1	Potable Water Design Criteria .....	7-2
7.2.2	Potable Water Required .....	7-3
7.2.3	Potable Water Specifications and Details.....	7-4
<b>7.3</b>	<b>FIRE DEMANDS .....</b>	<b>7-4</b>
7.3.1	Residential Developments .....	7-5
7.3.2	Fire Hydrant Requirements.....	7-5
7.3.3	Sprinklers .....	7-6
7.3.4	Commercial and Industrial Fire Demands .....	7-6
<b>7.4</b>	<b>SANITARY SEWER.....</b>	<b>7-8</b>
7.4.1	Projects Not Reasonably Accessible to Sewer .....	7-9
7.4.2	Sanitary Sewer Design .....	7-9
7.4.3	Sanitary Sewer Specifications and Standard Details .....	7-9

**TABLE OF CONTENTS**

7.4.4 Sanitary Sewer Service Lines..... 7-10

7.4.5 Required Sewer Infrastructure Upgrades..... 7-12

**7.5 GREASE CONTAINMENT ..... 7-12**

**7.6 DISPOSAL OF WASTES OTHER THAN DOMESTIC..... 7-12**

7.6.1 Sanitary Sewer Use Ordinance..... 7-12

7.6.2 Illicit Discharge Elimination Ordinance..... 7-12

Appendix 7A. Water Distribution Specifications ..... 7-15

Appendix 7B. Water Line Details..... 7-54

Appendix 7C. Sanitary Sewer Specifications ..... 7-77

Appendix 7D. Sanitary Sewer Details .....7-118

**8.0 CONSTRUCTION .....8-1**

**8.1 INTRODUCTION.....8-1**

**8.2 CONSTRUCTION PROCESS.....8-1**

8.2.1 Contacts .....8-1

8.2.2 Materials .....8-1

8.2.3 Submittals .....8-1

8.2.4 Preconstruction Meeting.....8-2

8.2.5 Installation Requirements.....8-2

8.2.6 Inspection and Testing.....8-3

8.2.7 Erosion Control .....8-3

8.2.8 Maintenance of Traffic.....8-3

8.2.9 Jobsite Safety.....8-3

**8.3 TRAFFIC SIGNAL CONSTRUCTION.....8-4**

8.3.1 Materials Submittal.....8-4

8.3.2 Testing.....8-4

8.3.3 Inspection.....8-5

8.3.4 Closeout .....8-5

**8.4 ROADWAY CONSTRUCTION.....8-5**

8.4.1 Clearing and Grubbing .....8-5

8.4.2 Subgrade .....8-5

8.4.3 Base.....8-6

8.4.4 Asphalt .....8-8

8.4.4.1 Patching.....8-8

8.4.4.2 Leveling.....8-9

**TABLE OF CONTENTS**

---

8.4.4.3 Milling .....8-9

8.4.4.4 Asphalt Overlays and New Pavement..... 8-10

8.4.5 Curb and Gutter ..... 8-11

**8.5 DRIVEWAY CONSTRUCTION ..... 8-11**

**8.6 DRAINAGE CONSTRUCTION ..... 8-12**

8.6.1 Storm Boxes and Curb Inlets..... 8-12

8.6.2 Storm Piping..... 8-14

8.6.2.1 Reinforced Concrete Pipe (RCP)..... 8-14

8.6.2.2 High Density Polyethylene (HDPE) Pipe..... 8-15

8.6.2.3 Side-drain/Driveway Pipe ..... 8-16

**8.7 UTILITY CONSTRUCTION ..... 8-16**

8.7.1 Water ..... 8-16

8.7.2 Sanitary Sewer ..... 8-17

8.7.2.1 Gravity Sanitary Sewer ..... 8-17

8.7.2.2 Sanitary Sewer Manholes ..... 8-17

8.7.2.3 Sewer Force Mains..... 8-17

8.7.2.4 Sanitary Sewer Pump/Lift Stations ..... 8-18

8.7.2.5 Closed Circuit Television (CCTV) Inspection ..... 8-18

DRAFT

# 1.0 GENERAL INFORMATION

## 1.1 INTRODUCTION

The Phenix City Public Works Manual (**Manual**) provides the requirements for developments within the City limits and planning and utility jurisdictions of the City of Phenix City (**City**). The Manual focuses on the roles and requirements of the City's Engineering and Public Works Department and the City's Utilities Department. It clarifies the basis for consistent design standards and policies including the minimum requirements for designing and constructing traffic control devices, streets, parking lots, sidewalks, bicycle facilities, greenways, transit facilities, retaining walls, dams, drainage facilities, erosion and sediment control devices, and utilities. The requirements in the Manual should be followed to expedite the processing and approval of projects.

### 1.1.1 Purpose of the Manual

The purpose of the Manual is to provide the requirements for engineering design and construction of projects within the City and its jurisdictions. The Manual also addresses the objective of protecting the public health, safety, and welfare by focusing on sound design and construction requirements.

The Manual consolidates many of the regulatory requirements of the City. Due to the authoritative and legal nature of some of these documents, this Manual will not function as a substitute for or replacement of any regulations. Instead, it is intended to complement existing ordinances and policies and help the City maintain current technical standards pertinent to engineering design and construction.

### 1.1.2 Use of the Manual

This Manual establishes the standards and requirements governing the quality of design and construction for plan preparation and project construction. Anyone who wishes to construct transportation and/or utility infrastructure within the City or its jurisdictions must use this Manual along with any applicable regulations, ordinances, and standards to ensure compliance with all applicable design and construction requirements.

Compliance with the Manual's standards and requirements may not meet all conditions necessary for project approval. Other City departments as well as State and Federal Agencies may have additional requirements that must be addressed to obtain approval.

The Manual is not intended to replace engineering judgment or innovative efforts. However, any deviations from the requirements of the Manual are subject to the City Engineer's approval.

### 1.1.3 Authority (Governing Regulations)

This Public Works Manual is established by the authority conferred by Resolution \_\_\_\_\_ of the City Council of the City of Phenix City, Alabama, which was adopted on \_\_\_\_\_, 2022, and is effective as of \_\_\_\_\_, 2022.

## 1.2 ABBREVIATIONS, ACRONYMS, AND DEFINITIONS

### 1.2.1 Purpose

This section defines abbreviations, acronyms, words, terms, and phrases contained within this Manual. If a term is not listed in this section or is not defined elsewhere in the Code of Ordinances, the Zoning Ordinance, the Subdivision Regulations, or Sections 11-52-30 through 11-52-36 of the 1975 Code of Alabama, as amended; then the conventional meaning of such term shall apply.

### 1.2.2 Word Usage

The present tense of a word includes the future tense, and the future tense of a word includes the present tense. The singular number includes the plural, and words in the plural number include the singular. The words “shall” or “must” are mandatory. The word “may” is permissive and indicates an action or choice that is usually beneficial.

Where any word specifically defined in the Code of Ordinances, the Zoning Ordinance, the Subdivision Regulations, or any other City policies is used in this Manual but not specifically defined herein, then the definition contained in the applicable ordinance or code shall apply.

Any confusion or questions regarding the definition of a term used in this Manual or a conflict with the definition as used in other City ordinances or codes shall be decided by the City Engineer whose decision shall be final.

### 1.2.3 Abbreviations and Acronyms

The following abbreviations and acronyms are referenced within the Public Works Manual and are intended to have the following meanings:

<b>AASHTO</b>	American Association of State Highway and Transportation Officials
<b>ADA</b>	Americans with Disabilities Act of 1990
<b>ADEM</b>	Alabama Department of Environmental Management
<b>ADT</b>	Average Daily Traffic
<b>ALDOT</b>	Alabama Department of Transportation
<b>ANSI</b>	American National Standards Institute
<b>ASD</b>	Allowable Stress Design

<b>ASTM</b>	American Society for Testing and Materials
<b>BFE</b>	Base Flood Elevation
<b>BMP</b>	Best Management Practices
<b>CBMPP</b>	Construction Best Management Practices Plan
<b>CBOD</b>	Carbonaceous Biochemical Oxygen Demand
<b>CBR</b>	California Bearing Ratio
<b>CCTV</b>	Closed Circuit Television
<b>CO</b>	Certificate of Occupancy
<b>DRP</b>	Downtown Redevelopment Plan
<b>EAP</b>	Emergency Action Plan
<b>EPA</b>	Environmental Protection Agency
<b>ESAL</b>	Equivalent Single Axle Load
<b>ESC</b>	Erosion and Sediment Control
<b>ESCP</b>	Erosion and Sediment Control Plan
<b>FEMA</b>	Federal Emergency Management Agency
<b>FHWA</b>	Federal Highway Administration
<b>fps</b>	Feet per Second
<b>ft</b>	Feet
<b>ft/sec</b>	Feet per Second
<b>FTA</b>	Federal Transit Authority
<b>Gals</b>	Gallons
<b>gpm</b>	Gallons per Minute
<b>HDPE</b>	High Density Polyethylene
<b>HVAC</b>	Heating, Ventilation, and Air Conditioning
<b>IDDE</b>	Illicit Discharge Detection and Elimination
<b>IFC</b>	International Fire Code
<b>ISMA</b>	International Municipal Signal Association
<b>ITE</b>	Institute of Transportation Engineers
<b>lbs/s.y.</b>	Pounds per Square Yard
<b>LDP</b>	Land Disturbance Permit
<b>LED</b>	Light-Emitting Diode
<b>LID</b>	Low Impact Development
<b>LOS</b>	Level of Service
<b>LRFD</b>	Load and Resistance Factor Design
<b>MG</b>	Million Gallons
<b>mg/l</b>	Milligrams per Liter
<b>mph</b>	Miles per Hour
<b>MS4</b>	Municipal Separate Storm Sewer System
<b>MSDSAR</b>	Materials, Sources and Devices with Special Acceptance Requirements
<b>MSE</b>	Mechanically Stabilized Earth
<b>MUTCD</b>	Manual on Uniform Traffic Control Devices
<b>NCHRP</b>	National Cooperative Highway Research Program
<b>NEC</b>	National Electrical Code

<b>NEMA</b>	National Electric Manufacturers Association
<b>NHI</b>	National Highway Institute
<b>NOAA</b>	National Oceanic and Atmospheric Administration
<b>NPDES</b>	National Pollutant Discharge Elimination System
<b>NRCS</b>	Natural Resources Conservation Service
<b>O&amp;M</b>	Operation and Maintenance
<b>OSHA</b>	Occupational Safety and Health Administration
<b>PMP</b>	Probable Maximum Precipitation
<b>ppm</b>	Parts per million
<b>PROWAG</b>	Public Rights-of-Way Accessibility Guidelines
<b>psi</b>	Pounds per Square Inch
<b>PUD</b>	Planned Unit Development
<b>PVC</b>	Polyvinyl Chloride
<b>QA/QC</b>	Quality Assurance / Quality Control
<b>QCI</b>	Qualified Credentialed Inspector
<b>QCP</b>	Qualified Credentialed Professional
<b>RCP</b>	Reinforced Concrete Pipe
<b>ROW</b>	Right of Way
<b>sec</b>	Second
<b>SF</b>	Square Feet
<b>SID</b>	Significant Industrial Discharger
<b>SOP</b>	Standard Operating Procedure
<b>SPT</b>	Standard Penetration Test
<b>Sq. Ft.</b>	Square Feet
<b>SWMP</b>	Storm Water Management Plan
<b>TIS</b>	Traffic Impact Study
<b>TR-55</b>	Technical Release 55 "Urban Hydrology for Small Watersheds"
<b>TRM</b>	Turf Reinforcement Matting
<b>TSS</b>	Total Suspended Solids
<b>Typ</b>	Typical
<b>UPS</b>	Uninterruptible Power Supply
<b>USDA</b>	United States Department of Agriculture
<b>USGS</b>	United States Geologic Service

#### 1.2.4 Definitions

When used, the following terms shall have the following meanings:

**85<sup>th</sup> Percentile Speed:** The speed at which 85% of the vehicles are traveling at or below.

**95<sup>th</sup> Percentile Speed:** The speed at which 95% of the vehicles are traveling at or below.



**Alley:** A public right-of-way primarily designed to provide a secondary access to the side or rear of properties.

**Applicant:** One (1) individual who is duly authorized to submit development plans for review, request variances or changes in zoning classification, and apply for any form of development approval with respect to a development site. An Applicant may be the property owner(s), or any person having written authority from the property owner(s). This written authority shall be provided in any form that the Planning Director and/or the City Engineer determine to be appropriate.

**Application for Development:** The application forms and all accompanying documents required by these regulations or other regulations for the approval of subdivision plans or site plans.

**Architect:** An architect properly licensed and registered in the State of Alabama.

**Arterial Road:** A facility that serves as a primary artery of the City intended to mainly carry through traffic and to connect major activity centers in the City and its planning jurisdiction. Its function is to move intra-city and intercity traffic. The streets that are classified as arterials may also serve abutting property; however, their primary purpose is to carry traffic. Arterials should not be bordered by uncontrolled strip development. Access to these facilities should be carefully managed to ensure the capacity of the facility is not compromised by driveways. Arterials vary in width and parking on-street is prohibited. (Note: A list of all current arterial roads in Phenix City is included in Appendix 4A of this Manual.)

**As-Built Survey:** A survey performed to show that all improvements on a site were constructed in compliance with the specifications as outlined by the Engineer during the design process.

**Backwater:** Water backed up or retarded in its course when compared with its normal or natural condition of flow.

**Basin:** A basin is an extent of land where stormwater drains downhill into a body of water, such as a river, lake, reservoir, estuary, wetland, or ocean. The basin includes both the streams and rivers that convey the water as well as the land surfaces from which water drains into those channels and is separated from adjacent basins by a drainage divide. The basin acts like a funnel, collecting all the water within the area covered by the basin and channeling it into a waterway. Each basin is separated topographically from adjacent basins by a geographical barrier such as a ridge, hill, or mountain, which is known as a water divide.

**Bench Test:** A test carried out on a machine, a component, or software before it is released for use, to ensure that it works properly.

**Best Management Practices:** A physical, structural or managerial practice, which has gained general acceptance for its ability to prevent or reduce environmental impacts.

**Bicycle Facilities:** Portions of the roadways or right-of-way allocated to bicycle use, such as bicycle lanes or bicycle routes, or facilities developed exclusively for the use of bicycles and non-motorized transportation, such as bicycle paths.

**Building:** A structure with a roof and walls, such as a house, school, store, or factory.

**Centerline:** That line surveyed, monumented and designated by the City as the centerline of a street.

**Certificate of Occupancy:** A certificate issued by a local authority indicating that a building meets minimum building code requirements for occupancy.

**Certified Traffic Signal Technician:** Individual who is certified to install, maintain, and repair highway traffic signal systems, including wiring, conduits, poles, heads, controllers, switches, vehicle detectors, and special illumination and painting in connection with these signals.

**Channelization:** The separation or regulation of conflicting traffic movements into definite paths of travel by traffic islands or pavement marking to facilitate the safe and orderly movements of both vehicles and pedestrians.

**City:** The City of Phenix City, Alabama.

**City Council:** The City Council of the City of Phenix City, Alabama.

**City Engineer:** The licensed engineer employed by the City and designated by the City Manager to furnish engineering assistance in the administration and enforcement of these regulations.

**Collector Road:** A street whose primary function is to collect traffic from an area and move it to the arterial street system while also providing substantial service to abutting land uses. A collector roadway will generally have lower design speeds than arterial roadways but higher than local street. Collector roads are shown on the City's Major Street Plan.

**Comprehensive Community Master Plan:** Latest edition of master plan for Phenix City which includes the City's vision, goals, planning recommendations, and implementation action items for land use, housing, economic development, transportation, infrastructure, education, community facilities, natural and cultural resources, and special planning areas.

**Contract:** A formal and legally binding agreement between the City and the Contractor.

**Contractor:** The individual, partnership, firm, or corporation that has entered into a contract with the City or a private developer to perform the work.

**County:** Russell County and Lee County

**Crest:** The highest elevation reached by flood waters flowing in a channel, as in crest stage or flood stage. The term crest can also refer to a crest vertical curve used in design processes to change the grade of a roadway.

**Cross Slope:** The transverse slope of a roadway perpendicular to the direction of travel.

**Crown:** The vertex of an arch or arched surface. Center of roadway elevated above the sides.

**Cul-de-sac:** A local street with one outlet and having an appropriate terminal for the safe and convenient reversal of traffic movement.

**Curb Cut:** Vehicular entrance onto a public right-of-way from a public or private development. The intersection of two public rights-of-way is not considered a curb cut.

**Curve Number:** A number between 0 and 100 that indicates the runoff potential of a soil/vegetation combination when the ground is not frozen. The higher the curve number, the higher the runoff potential.

**Dam:** A barrier that impounds water or underground streams. Dams generally serve the primary purpose of retaining water, while other structures such as floodgates or levees (also known as dikes) are used to manage or prevent water flow into specific land regions.

**Delineated Unsuitable Materials:** Materials deemed unsuitable for use within an earthwork, such as tree stumps, with their approximate limits identified by an engineering assessment of subsurface exploration findings.

**Design Flood:** The flood magnitude selected for use as a criterion in designing flood control works. The largest flood that a given project is designed to pass safely. In dam design and construction, the reservoir inflow-outflow hydrograph used to estimate the spillway discharge capacity requirement and corresponding maximum surcharge elevation in the reservoir.

**Design Speed:** A selected speed used to determine the various geometric features of the roadway. The assumed design speed should be a logical one with respect to the topography, anticipated operating speed, the adjacent land use, and the functional classification of the highway.

**Design Storm:** The rainfall or precipitation amount and distribution adopted over a given drainage area, used in determining the Design Flood.

**Designer:** The person focused on the engineering design process, either an engineer or an individual working under the responsible control of an engineer.

**Detention Pond:** A relatively small storage lagoon for slowing stormwater runoff, generally filled with water for only a short period of time after a heavy rainfall.

**Developer:** The legal or beneficial owner(s) of a lot or parcel or any land proposed for inclusion in a development, including the holder of an option, contract to purchase, or a lease.

**Development:** The division of a parcel of land into two (2) or more parcels (See Subdivision); the construction, reconstruction, conversion, structural alteration, relocation, or enlargement of any buildings; any use or change in use of any buildings or land; any extension of any use of land or any clearing, grading, or other movement of land, for which an approved development plan is required pursuant to the Zoning Ordinance or other regulations, codes and ordinances of the City.

**Drainage:** The removal of surface water or ground water from land by drains, grading, or other means. Drainage includes the control of runoff to minimize erosion and sedimentation during and after development and includes the means necessary for water-supply preservation or prevention or alleviation of flooding.

**Drainageway:** Minor watercourses, ravines, and ditches, natural or man-made, which are defined either by soil type or the presence of intermittent or perennial streams.

**Drawings:** All officially approved plans which are on file with the City, or exact reproductions thereof, showing alignment, layout and design of structures,

profiles, typical cross-sections, accessory features, and particular location, character, dimensions, and details of the work.

**Easement:** The privilege or right of one property owner making limited use of another property owner's adjacent property.

**Easement, Public:** An easement intended to accommodate utilities and/or drainage facilities; or to provide public access to pedestrian ways, bikeways, greenways, public parks and other public facilities. Such easements shall be accepted for dedication by resolution of the City Council.

**Engineer:** A company or person properly licensed in the State of Alabama to perform engineering services and designated by the City to act within the scope of authority and/or the particular duties entrusted to them.

**Engineering Judgment:** The scientific process by which a design, installation, operation/maintenance, or safety problem is systematically evaluated by a properly licensed engineer.

**Erosion:** The process by which rain, running water, waves, moving ice, and wind dislodge the upper layers of soil. As usually employed, the term includes weathering, solution, corrosion, and transportation.

**Excavation:** The process of moving earth, rock, or other materials with tools, equipment, or explosives.

**Factor of Safety:** Ratio of the resistance to a definition of failure by a material, structure, or system relative to the demand placed on a material, structure, or system. Various modes of failure have established and routinely expected levels of minimum factors of safety that should be confirmed by engineering analysis prior to beginning construction activities.

**Filling:** The depositing of sand, gravel, earth, or other materials to alter the elevation of a given site.

**Final Plat:** The map or plan or record of all or a portion of a subdivision, and any accompanying materials presented for final approval and recording as required.

**Fire Apparatus Access Road:** A road that provides fire apparatus access from a fire station to a facility, building, or portion thereof. This is a general term inclusive of all other terms such as fire lane, public street, private street, parking lot lane, and access roadway.

**Flood Routing:** The process of determining progressively downstream the timing and stage of a flood at successive points along a river. Also the determination of the attenuating effect of storage on a flood passing through a valley, channel, or reservoir.

**Floodplain:** Any land area susceptible to flooding

**Force Mains:** Pipelines that convey wastewater under pressure from the discharge side of a pump or pneumatic ejector to a discharge point.

**Foundation:** A structure that transfers loads to the earth. Foundations are generally broken into two categories: shallow foundations and deep foundations.

**Freeboard:** The vertical distance between a design maximum water level and the top of a structure such as a channel, dike, floodwall, dam, or other control surface. The freeboard is a safety factor intended to accommodate the possible effect of unpredictable obstructions, such as ice accumulations and debris blockage that could increase stages above the design water surface.

**Frontage Road:** A subsidiary road running parallel to a main road or highway and giving access to houses and businesses.

**Geosynthetic:** A fabric-like material made from polymers such as polyester, polyethylene, polypropylene, polyvinyl chloride (PVC), nylon, chlorinated polyethylene, and others. It can serve in several major functions: separation, reinforcement, filtration, drainage, and moisture barrier.

**Geotextile:** A fabric made from petroleum products or fiberglass. It has four major uses: drainage, filtration, separation, and reinforcement.

**Grade:** The slope of land or stream bed or a built feature such as a street, curb, gutter, etc, specified in percentage terms.

**Gravity Flow:** The downhill flow of water or sanitary sewage through a system of pipes, generated by the force of gravity.

**Greenway:** Interconnected corridors of natural land, preserved as open space, which follow natural, water, or man-made features. They connect people and places together, and when they include trails, they provide routes for alternative non-motorized transportation; a specific type of greenspace.

**HEC-RAS:** Computer program that models the hydraulics of water flow through natural rivers and other channels.

**Highway Capacity Manual:** A publication of the Transportation Research Board of the National Academies of Science in the United States that provides a collection of techniques for estimating the capacity and determining the level of service for transportation facilities.

**Horizontal Alignment:** A series of horizontal tangents (straight roadway sections), circular curves, and spiral transitions used for the roadway's geometry.

**Hydrograph:** A graph showing stage, flow, velocity, or other hydraulic properties of water with respect to time for a particular point on a stream.

**Hydrostatic Pressure:** The pressure exerted by a fluid at equilibrium at a given point within the fluid, due to the force of gravity.

**Impervious:** The portion of a sub-basin, sub-watershed, or watershed, expressed as a percentage, which is covered by surfaces that do not allow surface water penetration such as roof tops, parking lots, sidewalks, driveways, streets, and highways.

**Infiltration:** The process whereby the downward movement of precipitation is interrupted and redistributed.

**Infrastructure:** Facilities and services needed to sustain industrial, residential, and commercial activities. Infrastructure may include, but not be limited to, water and sewer lines, streets, communication lines, drainage facilities, and utilities.

**Intersection Sight Triangle:** Areas at the corners of intersections of roads and driveways where views of approaching traffic should not be obstructed.

**Interstate:** Controlled access facilities with four or more lanes that provide fast and efficient movement of large volumes of traffic over a considerable distance by prohibiting access (ingress and egress) except at controlled intervals.

**Karst Topography:** A landscape that is characterized by numerous caves, sinkholes, fissures, and underground streams.

**Landscape Architect:** A landscape architect properly licensed and registered in the State of Alabama.

**Level of Service (LOS):** A qualitative measure describing traffic conditions along a given roadway or at a particular intersection, including travel speed and time, freedom to maneuver, traffic interruptions, and comfort and convenience as experienced and perceived by motorists and passengers. Six levels are defined from A to F, with A representing the best conditions and F the worst.

**Licensed Professional Engineer:** An engineer properly licensed and registered in the State of Alabama.

**Local Commercial Streets:** All minor streets, marginal access streets and cul-de-sacs serving primarily commercial developed property. (Note: A list of all current local roads in Phenix City is included in Appendix 4A of this Manual.)

**Local Residential Streets:** All minor streets, marginal access streets and cul-de-sacs serving primarily residential property. (Note: A list of all current local roads in Phenix City is included in Appendix 4A of this Manual.)

**Lot:** A parcel of land occupied by or designated to be developed for one (1) or more buildings or principal uses, and the accessory buildings or uses customarily incidental to such uses including such open spaces and yards as are designed and arranged or required by this Manual for such building, use, or development (see also Development Site).

**Lot, Corner:** A lot abutting two (2) or more streets at their intersection. If the two (2) streets form an angle of more than 135 degrees, as measured at the point of intersection of their center lines, the lot shall not be considered a corner lot.

**Lot, Double Frontage:** A lot, other than a corner lot, which has frontage on more than one street.

**Lot Line:** A line bounding a lot which divides one lot from another or forms a street or any other public or private space.

**Luminaire:** A complete lighting unit consisting of a lamp or lamps together with the parts designed to distribute the light, to position and protect the lamps, and to connect the lamps to the power supply.

**Maintenance Bond:** A type of surety bond purchased by a contractor or owner that protects the owner of a completed construction project for a specified time period against defects and faults in materials, workmanship, and design that occur prior to the bond's expiration date.

**Mechanically Stabilized Earth (MSE) Wall:** Soil constructed with artificial reinforcing. It can be used for retaining walls, bridge abutments, dams, seawalls, and dikes. The reinforcing elements used can vary but include steel and geosynthetics.



**National Electrical Code (NEC):** The benchmark for safe electrical design, installation, and inspection to protect people and property from electrical hazards.

**National Electrical Safety Code:** A United States standard of the safe installation, operation, and maintenance of electric power and communication utility systems including power substations, power and communication overhead lines, and power and communication underground lines.

**NEMA-Compatible Controller:** A traffic signal controller that is compatible with the National Electrical Manufacturers Association's (NEMA) minimal functional standards.

**Noncircular Failure:** A slip surface within a soil and/or rock mass that is not circular and can be irregular based on the presence of locally weaker materials. Most commercially available computer programs that facilitate slope stability analysis allow for evaluation of circular and noncircular failure surfaces to aid identification of the critical slip surface.

**NQ Core:** Size of rock core commonly collected by core drilling techniques. The outside diameter of collected core is 1.875 inches.

**NRCS Curve Number Method:** Relates soil type, soil cover, land use type, and antecedent moisture conditions to a curve number. Used to determine the depth of runoff for a given area.

**Open Channel:** A system of conveyance channels in which the top flow boundary is a free surface (e.g., ditches, flumes).

**Overtopping:** To rise above; exceed in height; tower over.

**Owner:** A person who, or entity which, alone, jointly or severally with others, or in a representative capacity (including, without limitation, an authorized agent, attorney, personal representative or trustee) has legal or equitable title to any property in question.

**Parcel:** See Lot, Development Site.

**Peak Flow:** The maximum flow rate of the hydrograph.

**Peak Hour:** A part of the day during which traffic congestion on roads is at its highest.

**Performance Bond:** A surety bond issued by an insurance company or a bank to

guarantee satisfactory completion of a project by a contractor.

**Planning Commission:** The Phenix City Planning Commission acts as an advisory board to the City Council on all planning and development issues, including the development and maintenance of the Comprehensive Community Master Plan, and assures that the Comprehensive Plan is implemented by reviewing development applications on a case-by-case basis.

**Plans:** See Drawings

**Plasticity Index:** Range of moisture contents where soil exhibits plastic properties. Difference between liquid and plastic limit as defined by ASTM D 4318.

**Plat:** A plan, map, or chart of a piece of land with actual or proposed features.

**Ponding:** The natural formation of a pond by an interruption of the normal streamflow.

**Ponds:** Natural or artificial bodies of water which retain water year round. A pond is a body of water of less than two (2) acres. Artificial ponds may be created by dams or may result from excavation. The shoreline of such bodies of water shall be measured from the maximum condition rather than from the permanent pool in the event of any difference.

**Precondition Survey:** Paper or video documentation of the conditions of a dwelling or structure, including cracks and other distress. The precondition survey is intended to protect all parties relative to possible damage and/or damage claims after blasting.

**Preconstruction Conference:** A meeting that is held prior to starting construction to define the responsibilities of the construction team and the procedures necessary for job execution.

**Preliminary Plat:** A map and related materials indicating the proposed layout of a development submitted for preliminary approval in accordance with all requirements.

**Probable Maximum Precipitation:** The greatest depth of precipitation for a given storm duration that is physically possible over a particular drainage basin at a certain time of year.

**Proposal:** The written offer for the work, when submitted by the bidder in the required manner on the prescribed proposal form properly signed and guaranteed.

**Public Hearing:** An open gathering of officials and citizens where citizens are permitted to offer comments.

**Queue:** A line or sequence of people or vehicles awaiting their turn to proceed.

**Radius of Curvature:** The reciprocal of the curvature. For a curve, it equals the radius of the circular arc which best approximates the curve at that point.

**Rational Method:** A simple procedure for calculating the direct precipitation peak runoff from a watershed, using the rainfall intensity, the area of the watershed, and the runoff coefficient appropriate for the type of watershed runoff surface.

**Retaining Wall:** A structure that holds back soil or rock from a building, structure or area. Retaining walls prevent downslope movement and provide support for vertical or near-vertical grade changes.

**Retention Pond:** A permanent pond used to slow storm water runoff and promote infiltration into the groundwater. See Wet Retention Pond and Dry Detention Pond.

**Return Period:** The mean number of such time units necessary to obtain a value equal to or greater than a certain value one time. For example, with a 1-year interval between observations, a return period of 100 years means that, on average, an event of this magnitude or greater is not expected to occur more often than once in 100 years.

**Review Team:** Team of peers with assigned roles who perform a well-defined review process to identify issues of non-compliance for correction.

**Right-of-Way:** A strip of land used or intended to be used for passage of the general public and occupied or intended to be occupied by a street, road, bicycle path, pedestrian way, crosswalk, utilities, railroad or similar facility; and dedicated to public use through acceptance by the City Council.

**Roadway:** The portion of a right-of-way intended for use by vehicular and bicycle traffic.

**Running Slope:** The slope of a surface which is parallel to the direction of travel.

**Scale:** The relative proportion of the size of different elements of the built environment to one another; the measurement of the relationship of one object to another.

**Sharrows:** A road marking in the form of two inverted V-shapes above a bicycle, indicating which part of a road should be used by cyclists when the roadway is shared with motor vehicles.

**Shelby Tube:** Aluminum thin-wall pipe used to attempt collection of fine-grained soils with minimal disturbance by hydraulic pushing of the pipe. Sample collection guidance is provided by ASTM D 1587.

**Shop Drawings:** Fabrication plans for any part of the work including, but not limited to, water and sanitary mains and appurtenances, precast concrete items, structural steel items, or other metal items, and connections thereof, which the contractor is required to submit to the City Engineer.

**Sidewalk:** A paved path provided for pedestrian use.

**Sight Distance:** The length of roadway visible to a driver as defined in the AASHTO Green Book.

**Signal Warrant Analysis:** An analysis that determines if an intersection meets the required criteria to justify a traffic signal installation.

**Site Plan:** A plan, drawn to scale by a licensed engineer or other qualified professional, showing uses, structures, and all other physical features proposed for the development site, including bufferyards, parking, landscaping, and drainage facilities, in accordance with the requirements of the Zoning Ordinance.

**Specifications:** Written technical and other requirements for the Work, prepared by or on behalf of the City, which are on file with the City, containing directions, provisions, and technical and general requirements for the Work, together with such as may be added as Supplemental Specifications or Provisions.

**Split Phasing:** A traffic signal design that gives a green phase for all vehicle movements of one direction followed by a phase for all movements of the opposite direction.

**Spread:** The width of water transported on the pavement measured from the face of the curb.

**SPT N Value:** In accordance with ASTM D 1586, the number of blows/drops of a 140 pound weight that free falls 30 inches is required to drive a split-spoon

sampler between 6 and 18 inches of penetration. The resultant N value has units of blows per foot of penetration.

**Standard Drawings:** Drawings approved for repetitive use or accepted by the City showing details to be used where appropriate.

**Standard Specifications:** A book of specifications approved or accepted by the City for general application and repetitive use.

**Standpipe:** A series of pipes which connect a water supply to hose connections, basically an extension of the fire hydrant system.

**State:** The State of Alabama.

**Stopping Sight Distance:** The distance needed for drivers to see an object on the roadway ahead and bring their vehicles to a safe stop before colliding with the object.

**Street:** Any street, avenue, boulevard, road, parkway, viaduct, drive, or other right-of-way provided for vehicular traffic and travel.

**Street, Loop:** A circular or semi-circular road designed around landscaped greenspace or a rain garden, with outlets that begin and end on the same road. A one-way loop street can be used as an alternative to the cul-de-sac.

**Subdivider:** Any person who, having an interest in land, causes it directly or indirectly, to be divided into a subdivision as defined herein.

**Subdivision:** Any division, redivision, or consolidation of a tract, parcel, or lot of land by means of mapping, platting, conveyance, change or rearrangement of boundaries in accordance with the Subdivision Regulations. All subdivisions are also developments (See Development).

**Subdivision Regulations:** The Subdivision Regulations of the City of Phenix City, Alabama.

**Subgrade:** The soil or rock leveled off to support the foundation of a structure or roadway.

**Taper:** A series of channelizing devices or pavement markings placed to move traffic out of or into its normal path.

**Time of Concentration:** The time required for water to flow from the hydraulically farthest point on the watershed to the gauging station, culvert, or other point of interest.

**Traffic Calming:** A set of techniques that serves to reduce the speed of traffic. Such strategies include lane narrowing, traffic circles, sharp offsets, yield points, sidewalk bulge-outs, surface variations, and visual clues on a vertical plane.

**Traffic Impact Study:** An evaluation of the adequacy of the existing or future transportation infrastructure to accommodate additional trips generated by a proposed development, redevelopment, or land rezoning.

**Trip Distribution:** A model of the number of trips that occur between each origin zone and each destination zone.

**Turnout:** The portion of a driveway or side road that connects to a public road.

**Vertical Clearance:** The minimum specified height of a bridge or overhead projection above the roadway.

**Water Supply:** The system made up of water sources, treatment, and conveyance systems to provide potable water and fire protection to the community.

**Watershed:** An area of land, due to its natural drainage pattern, that collects precipitation and drains or seeps into a marsh, stream, river, lake or groundwater. Topography is the key element affecting this area of land. The boundary of a watershed is defined by the highest elevations surrounding the stream. A drop of water falling outside this boundary will drain to another watershed.

**Weep Hole:** A small opening in the fascia of a retaining wall that allows water to drain by gravity from within a retaining wall.

**Wetland:** An area that is inundated or saturated by surface water or groundwater at a frequency and duration sufficient to support, and that, under normal circumstances, does support, a prevalence of vegetation typically adapted for life in saturated soil conditions, commonly known as hydrophytic vegetation. Wetlands generally include swamps, marshes, bogs, and similar areas. Standards for defining wetland boundaries consider hydrology, vegetation, and soil conditions.

**Work (The Work):** All performance required of the Contractor under the terms of the Contract.

**Zoning Ordinance:** A set of land use regulations enacted by the City of Phenix City to create districts, which permit certain land uses and prohibit others. Land uses in each district are regulated according to type, density, height, and the coverage of buildings.

## 1.3 DEVELOPMENT PROCESS

### 1.3.1 Overview

Any proposed development within the City of Phenix City is classified as either a subdivision project or a site development project. Based on the development's classification, the review and approval processes may vary. This section explains the process to obtain approval for a development. The Developer should consult with the City Departments early in the project to obtain advice and to receive guidance on the review and approval process.

### 1.3.2 Subdivision and Residential Projects

The subdivision of land must follow the requirements of the Phenix City Subdivision Regulations and must be approved by the Planning Commission. The Developer shall follow the process below to seek approval of a proposed subdivision.

#### 1.3.2.1 Pre-Application

The Developer shall submit a lot layout sketch to the Planning Commission Recording Secretary. It should include the location of the proposed subdivision, existing features (i.e., highways, drainage facilities, railroads, water bodies, etc.), site topography, and the proposed layout of the streets, lots, and blocks. The Planning Commission Recording Secretary will distribute the sketch to the City Departments who will review it and meet with the Developer to discuss the layout. If the City is agreeable, the Developer may prepare the Preliminary Plat for the subdivision.

#### 1.3.2.2 Preliminary Plat

The Developer shall submit a Preliminary Plat to the Planning Commission Recording Secretary. This submittal shall also include a completed Petition for Subdivision (see Appendix 1A), a complete legal description, and a list of names and mailing addresses of all adjoining and adjacent property owners. The information required on the preliminary plat, the number of copies required, the schedule of required fees, and the deadline for submittal are specified in the Phenix City Subdivision Regulations.

All City Departments will review the Preliminary Plat and provide input regarding adherence to the Subdivision Regulations and conformity with the Comprehensive Community Master Plan. The Planning Commission will also review the Preliminary Plat. If it is deemed acceptable, they will consider it for approval at a Public Hearing. Following the hearing, the Planning Commission will approve, approve conditionally, or disapprove the Preliminary Plat. Details of the approval process are spelled out in the Subdivision Regulations. If the Preliminary Plat is approved, the Developer may prepare Construction Plans.

### **1.3.2.3 Construction Plans**

Upon approval of the Preliminary Plat and prior to construction, the Developer shall prepare and submit Construction Plans to the Planning Commission Recording Secretary. Plans shall be signed and sealed by a licensed Professional Engineer registered in the State of Alabama and shall include a Title Sheet, Boundary Survey Sheet, Site Layout Plan Sheet, Plan and Profile Sheets for all roadways, Grading and Erosion Control Plan Sheet, Overall Utility Plan, Cross-Section Sheets, and Detail Sheets. Additional construction plan information including sheet size, required general notes, and the number of copies required are specified in the Phenix City Subdivision Regulations. The submittal shall also include all design calculations, a completed Land Disturbance Permit Application and Checklist (see Appendix 1C), and a wetland assessment performed by a qualified professional. All required permits and clearances must be submitted to the Engineering Department prior to their approval.

Upon approval from the Engineering Department, the Developer shall participate in a Preconstruction Meeting with the appropriate City Departments and shall notify the City Engineer, other City Departments, and the appropriate County Engineers (Russell County or Lee County) prior to starting construction. Construction requirements are specified in Section 8.0 – Construction.

### **1.3.2.4 Final Plat and As-Built Survey**

Upon completion of construction including all punch list items, a Final Plat and As-Built Survey shall be submitted to the Planning Commission Recording Secretary. The information required on the Final Plat and As-Built Survey, the number of copies required, the deadline for submittal, and a description of required certificates are specified in the Phenix City Subdivision Regulations. The As-Built Survey shall conform to the Standards of Practice for Surveying in the State of Alabama and shall be certified by a Licensed Surveyor in the State of Alabama.

The submittal shall also include Performance Bonds, a Maintenance Bond, a list of any protective covenants, a certificate from a Land Surveyor regarding permanent monuments, detailed final quantities with cost estimates, certifications from the Design Engineer ensuring conformity with the construction plans and Subdivision Regulations, and a plan for detention pond maintenance (if applicable). Details for each of these documents are specified in the Subdivision Regulations.

### **1.3.2.5 Action on Final Plat**

The Planning Commission shall approve the Final Plat and As-Built Survey after all conditions have been fulfilled in accordance with the Preliminary Plat and



proper installation of the improvements has been certified. The Developer shall record the Final Plat in the office of the Judge of Probate of Russell County or Lee County after approval. The number of required copies, bond requirements, and the deadline for this submittal are specified in the Subdivision Regulations.

**1.3.2.6 Administrative Subdivision**

If a resubdivision has no more than five contiguous lots fronting an existing street and no proposed new streets, the City Engineer may classify it as an Administrative Subdivision. In this case, engineering services are not needed, and the Developer does not need to submit a Preliminary Plat or Construction Plans. The Developer shall submit a Final Plat for an Administrative Subdivision which meets all requirements listed in Section 1.3.2.4 of this Manual and in the Subdivision Regulations. The Planning Commission must receive a completed Petition for Subdivision (see Appendix 1A), a complete legal description, and the Final Plat prior to granting approval of an Administrative Subdivision.

**1.3.3 Site Development Projects**

Site development projects include proposed non-residential construction projects. Site plan approvals may require rezoning, conditional use approval, and/or a traffic impact study. All site plans must be presented to the City and approved before any construction is allowed on the site.

**1.3.3.1 Permitted Uses**

The City's Zoning Ordinance identifies which uses are permitted. It shall be the property owner's responsibility to coordinate with the City to determine that the proposed project is a permitted use that meets all provisions of the Zoning Ordinance. If the project is not a permitted use, conditional use approval is required by the City Council.

**1.3.3.2 Conditional Uses**

The City's Zoning Ordinance identifies uses which are permitted only upon approval of a conditional use application. Conditional uses must be consistent with the Comprehensive Plan, the Zoning Ordinance, and any other City development policies and/or regulations.

To request a conditional use, the Developer must submit a Petition for Conditional Use (see Appendix 1B) to the Planning Commission Recording Secretary. A site plan and a list of names and mailing addresses of adjoining and adjacent property owners must be submitted with the petition. Following a public hearing, the Planning Commission will recommend that the conditional use be approved, approved with conditions, or denied. After receiving the Planning Commission's recommendation, the City Council will ultimately approve

or deny the request for conditional use.

#### **1.3.3.3 Traffic Impact Study**

Depending on the type, size, and intensity of a development, the City may require a Traffic Impact Study. The study may be required concurrent with a rezoning request, conditional use request, or during the site plan project approval process. The requirements of a Traffic Impact Study are discussed in detail in Section 3.0 – Traffic Impact Studies.

#### **1.3.3.4 Pre-Application**

The Developer shall submit a site plan sketch to the Planning Commission Recording Secretary. It shall include the location of the proposed site, existing features (i.e., highways, drainage facilities, railroads, water bodies, etc.), site topography, and the proposed layout of the structures, roadways, and parking areas. The Planning Commission Recording Secretary will distribute the sketch to the City Departments who will review it and meet with the Developer to discuss the layout. The City will communicate any general comments or concerns to be implemented into the construction plans for the site development. After this meeting, the Developer may prepare the construction plans.

#### **1.3.3.5 Construction Plans**

Regardless of the size of the development, construction plans must be submitted by the Developer and approved by the City before any work can begin on the site. Plans shall be signed and sealed by a licensed Professional Engineer registered in the State of Alabama. The submittal shall also include a completed Land Disturbance Permit Application and Checklist (see Appendix 1C). Specific requirements for engineering plans are shown in the Land Disturbance Checklist.

If the development meets the requirements shown in Section 8.2.4, the Developer shall participate in a Preconstruction Meeting with the appropriate City Departments after receiving plan approval from the City's Engineering Department. The Developer shall notify the City Engineer, other City Departments, and the appropriate County Engineers (Russell County or Lee County) prior to starting construction. Construction requirements are specified in Section 8.0 – Construction.

### **1.3.4 Rezoning**

Property owners may request a zoning change by submitting a Petition for Rezone to the Planning Commission Recording Secretary. A plat of the property, a complete legal description, and the names and mailing addresses of all adjoining and adjacent property owners must be submitted with the Petition. Specific requirements for the plat,

submittal deadlines, fees, and a copy of the Petition for Rezone is included in Appendix 1D.

### 1.3.5 Permits

The City requires permits to ensure that proper requirements, conditions, and standards are adhered to in design and construction. The permits also help the City monitor progress and ensure quality in the constructed project. There are several departments within the City from which permits are required during specific points in the design and construction process. Pertinent permits that are issued by the City include:

- Land Disturbance Permit
- Burn Permit
- Permit to Construct a Turnout to Provide Access to a City Street (Commercial and Residential)
  
- Building Permit
- Electrical Permit
- Plumbing Permit
- Gas Fitting Permit
- HVAC / Mechanical Permit
- Certificate of Occupancy
- Swimming Pool Permit
- Demolition Permit
- Sign Permit
- House Moving Permit
- Food Service Establishment Permit

All permits are available on the City's website along with a corresponding fee schedule and specific requirements and guidelines for each permit.

Each permit is discussed below. However, this information is not meant to provide all details regarding each permit. The Developer should refer to the appropriate regulation, ordinance, or code that describe the permit requirements in more detail. Performing any work without the required/appropriate permit will result in a stop work order and a potential fine.

#### 1.3.5.1 Land Disturbance Permit

Prior to disturbing an area greater than or equal to one acre, a Land Disturbing Permit must be obtained. The engineer of record must submit a CBMPP with corresponding engineering plans to the City's Engineering Department for review. After the plans have been approved, any other required State and Federal permits have been obtained, and copies of all permits have been submitted to the Engineering Department, then the Engineering Department will

issue the Land Disturbing Permit.

**1.3.5.2 Burn Permit**

Burn Permits are required within the fire jurisdiction of the City of Phenix City. Construction burn permits are free and valid for two weeks. Permits are issued by the Phenix City Fire/Rescue Department.

**1.3.5.3 Permit to Construct a Turnout to Provide Access to a City Street (Commercial and Residential)**

These permits are issued by the City Engineering Department prior to construction of a commercial or residential driveway onto a City street. The permits are valid for one year from the date of application. The applicant must contact the Engineering Department for a site evaluation prior to beginning work on the driveway. A pre-poured framing inspection is also required. The applicant must adhere to all EPA and ADEM regulations throughout the construction process. The permit applications are included in Section 4.0 – Roadway and Parking Design.

**1.3.5.4 Building Permit**

Building Permits are issued by the Phenix City Building Department. Applications must include proof of a State of Alabama Home Builders License (residential), State of Alabama General Contractor License (non-residential), and a City of Phenix City Business License. Completed design plans, a site plan, energy forms, a subcontractor list, and any applicable driveway permits shall also be submitted with the application. Throughout construction, all provisions of the Building Laws and Zoning Ordinance shall be followed.

**1.3.5.5 Electrical Permit**

Electrical Permits are issued by the Phenix City Building Department. Applicants must have a current State of Alabama Electrical License and a City of Phenix City Business License.

**1.3.5.6 Plumbing Permit**

Plumbing Permits are issued by the Phenix City Building Department. Applicants must have a current State of Alabama Plumbers License and a City of Phenix City Business License.

**1.3.5.7 Gas Fitting Permit**

Gas Fitting Permits are issued by the Phenix City Building Department. Applicants must have a current State of Alabama Gas Fitters License and a City of Phenix City Business License.

**1.3.5.8 HVAC / Mechanical Permit**

HVAC / Mechanical Permits are issued by the Phenix City Building Department. Applicants must have a current State of Alabama HVAC License and a City of Phenix City Business License.

**1.3.5.9 Certificate of Occupancy**

Certificates of Occupancy are issued by the Phenix City Building Department. Commercial structures must be approved by the City of Phenix City Fire Code Official and a Code Enforcement Officer. New buildings must pass final inspection. Home businesses will require a signed Home Occupancy Statement and proof of home ownership or approval from the landlord to operate the home-based business.

**1.3.5.10 Swimming Pool Permit**

Swimming Pool Permits are issued by the Phenix City Building Department. Applicants must have a current State of Alabama General Contractor License and a City of Phenix City Business License. A site plan produced from an accurate field survey showing the proposed pool, nearby structures, all utilities, all easements, and a fence must be submitted with the permit application.

**1.3.5.11 Demolition Permit**

Demolition Permits are issued by the Phenix City Building Department. Applicants must have a City of Phenix City Business License and must provide written verification that all utilities within the demolition site have been disconnected.

**1.3.5.12 Sign Permit**

Sign Permits are issued by the Phenix City Building Department. Applicants must have a City of Phenix City Business License. A site plan and two complete sets of plans must be submitted with the application.

**1.3.5.13 House Moving Permit**

House Moving Permits are issued by the Phenix City Building Department. Applicants must have a City of Phenix City Business License.

**1.3.5.14 Food Service Establishment Permit**

Food Service Establishment Permits are issued by the Phenix City Building Department. Applicants must have a Food Service Permit from the County Health Department and a City of Phenix City Business License.

**1.3.5.15 Other Permits**

It is not the responsibility of this Manual or the City to inform each development applicant of all permits that may be required. Applicants should note that other governmental agencies may require additional permits under their respective jurisdictions. The applicant may be required to obtain various permits from County, State and Federal agencies for a project. It is the responsibility of the applicant to determine which permits are required.

## **1.4 EASEMENTS**

### **1.4.1 Overview**

When a project constructs facilities that will be publicly owned and maintained outside of public ROW or within an existing easement, a new easement must be dedicated. Easements shall be dedicated either by document or by plat. All easements needed for a development shall be identified during the plan review process. Off-site easements shall be acquired by the Developer. These off-site easements shall be recorded by deed of easement prior to construction approval and shall be dedicated to the City.

### **1.4.2 Dimensions**

The standard easement width for water, sewer, and storm drain is based on two times the depth of cover (measured from finished grade to the bottom of the pipe or structure) plus the width of the pipe(s) rounded up to the nearest multiple of five (5) feet with a minimum easement width of twenty (20) feet. The easement shall be centered upon the utility. Utility and drainage easements may be combined, subject to approval by the City Engineer, and shall be at least thirty (30) feet wide, fifteen (15) feet on each side of the property lines of lots. The easement widths shall be extended when necessary to provide space for utility bracing and other construction.

Easements for installation of water and sewer utilities may require additional width to ensure a 10-foot separation between structures and the installed utility. The actual easement width shall be calculated based on the actual installed depths. The infrastructure shall be centered in the easement and shall be verified in the as-built drawings. If it is determined that the water, sewer, or storm drain line was not installed in the dedicated easement to allow for proper maintenance, then the easement shall be promptly rededicated in the installed location. The City will typically accept a tolerance of up to eighteen (18) inches before a rededication of the easement will be required.

### **1.4.3 Obstructions and Access**

No fences, trees, or any other obstructions shall be allowed in easements without City approval. In cases where easement obstructions are allowed by the City, a Hold Harmless Agreement will be required with the dedication of the easement. The developer shall provide adequate access along all easements for maintenance/construction equipment and vehicles. Adequate access requires a stable

and drivable path for said equipment and vehicles. All permanent easements shall be graded and smoothed to allow access and use by mowing equipment and maintenance vehicles prior to acceptance by the City. Permanent easements shall be completely cleared of all trees, brush, boulders, and debris. All rocks shall be buried, crushed, or removed from the easement where, in the opinion of the City, they present a hazard for access and use of the easement. Typically, no rock shall remain on the ground surface that is larger than a No. 1 stone classification. All creek and ditch crossings shall also be made accessible for mowing and maintenance equipment as deemed appropriate by the City.

#### **1.4.4 Service Activations**

Water or sewer services shall not be activated prior to the legal dedication of all necessary easements. Prior to easement dedication, any testing and water main disinfection procedures may proceed in order to complete construction, but domestic services shall not be provided until the necessary easements are granted.

#### **1.4.5 Dedications**

All water and sewer utility and storm drain easements shall be dedicated to the City as Drainage and Utility Easements unless otherwise approved and shall not be combined with any other utility easements (i.e., gas, electric, communications, etc.). City Drainage and Utility Easements are exclusive and shall not be used to install other non-City owned and maintained utilities. One possible exception is when another utility requires a perpendicular crossing. Where other utilities must be installed inside a City of Phenix City Drainage and Utility Easement and where approved by the City, an Easement Encroachment Agreement will be required for the encroaching utility.

##### **1.4.5.1 Dedication by Document**

Easements to be dedicated by document shall include a vicinity map showing the general location of the property, a legal description of the easement area, and a surveyed drawing showing the easement limits and the installed location of the utility. The legal description and drawing shall be prepared by a licensed professional land surveyor in the State of Alabama. The full easement package shall be submitted to the City Engineer for review and approval along with as-built drawings for the development.

After the legal description and exhibit have been submitted and approved, the City will assist the Developer in submitting it to City Council for approval. After City Council has approved the easement document, the Developer shall coordinate with the City to record the easement. Proof of ownership will be required before the easement document can be recorded and must be in a form acceptable to the City.

#### 1.4.5.2 Dedication by Plat

Easements to be dedicated by plat shall be identified during the review process and shall be shown on the preliminary plat included in the plans. All plats shall be prepared by a licensed professional land surveyor in the State of Alabama and shall be submitted to the City for review. Plats shall adhere to all applicable City Zoning Ordinances and Subdivision Regulations. All easements shall be shown and clearly labeled on the plat. The easement widths shall be clearly identified and shall meet the easement width requirements based on proposed installation depths.

All easements shown on the final plat shall be in the as-built location of the infrastructure and shall be surveyed by a licensed professional land surveyor in the State of Alabama prior to submittal. If the final plat is recorded prior to infrastructure being installed, the City shall check the recorded plat against the surveyed as-built drawings prior to accepting the infrastructure. If any discrepancies are discovered between the recorded easement and as-built locations or if installed depths would hinder the maintenance or repair of the infrastructure, the Developer will be required to revise the plat and easements as necessary prior to preliminary acceptance of the affected infrastructure.

### 1.5 WARRANTY PERIOD

The Developer is responsible for repairing all damages caused to infrastructure within the development due to construction activity as well as any defects in materials and workmanship associated with the installed infrastructure for a period of not less than two years from the date of the City's final written acceptance of the infrastructure, or the signing of the final plat, whichever is later.

The Developer shall notify the City of Phenix City Utilities Department of any repairs or maintenance needed on the water and/or sanitary infrastructure, and the Developer shall coordinate with said Utilities Department to have a Utilities Department representative present to observe any repairs and/or maintenance provided by the Developer to said infrastructure. The City may provide repair and emergency response services for water and sanitary sewer related issues within the development after preliminary acceptance and during the warranty period if the issues are not timely and satisfactorily addressed by the Developer.

The Developer will be responsible for all costs associated with any repairs or emergency response services provided by the City during the preliminary acceptance or warranty periods. Costs will include all labor, equipment, materials, and contractor fees for the work.

When new infrastructure which is going to be dedicated to the City of Phenix City is under warranty, the developer is responsible for said infrastructure which includes but is not limited to repairs, maintenance, stoppages, and underground utility marking.



## 1.6 UPDATES AND WAIVERS

### 1.6.1 Manual Updates

Updates to this Manual will be issued as needed. All updates will be posted on the City's website along with the date that the revisions go into effect. Manual users may suggest revisions to the Manual by submitting their suggestions to the City in writing. If the City agrees that the requested revisions are appropriate, the Manual will be updated. The full Manual will be reviewed and updated as needed. Manual users are responsible for ensuring that they are using the most current version.

### 1.6.2 Project Specific Waivers

The City may make project specific waivers to an existing City standard when one of the following conditions applies.

1. The standard is not applicable to the situation.
2. Topography, right-of-way, or other geographical conditions impose undue hardship to the Developer as determined by the City Engineer or extraordinary environmental damage and an equivalent alternative that can achieve the same design objective is available and does not compromise public safety.
3. A waiver is required to address a specific design or construction problem that will result in an undue hardship to the Developer with little or no material benefit to the public if not granted.
4. A new technology is available that results in an economic benefit to the project, accomplishes the same design objective, reduces environmental intrusion, and does not compromise public safety.

While the City is not required to issue a waiver, they will only consider waivers for these four conditions. To apply for a waiver, the Developer must submit a written waiver request. The request shall be submitted to the proper governing authority on the City's Request for Waiver form (see Appendix 1E) and shall state why a waiver is being requested, facts relevant to the waiver request, and an explanation of why the Developer feels that the waiver should be approved.

The proper governing authority will review the completed Request for Waiver form and any relevant attachments and will respond in writing to either approve the waiver as requested, approve the waiver with conditions, or deny the waiver request. An explanation will be provided with conditional approvals and denials. Any approved waiver is project specific and does not indicate a precedent for standard modification.

## **References**

*Code of Ordinances of the City of Phenix City, Alabama* (Amended January 25, 2021)

*Phenix City's Zoning Ordinance* (Amended July 15, 2014)

*Phenix City's Subdivision Regulations* (Amended and Approved April 12, 2016)

*Code of Alabama* (1975)

*Standards of Practice for Surveying in the State of Alabama* (2017)

*A Policy on Geometric Design of Highways and Streets*, 7th Edition, American Association of State Highway and Transportation Officials (2018) (AASHTO Green Book)

DRAFT

**APPENDIX 1A**  
**PETITION FOR ADMINISTRATIVE SUBDIVISION**

DRAFT

DRAFT



DRAFT

**THE FOLLOWING INFORMATION MUST BE SHOWN ON ALL PLATS TO BE SUBMITTED FOR AN ADMINISTRATIVE SUBDIVISION.**

- 1) TITLE
- 2) DATE
- 3) NAMES, ADDRESSES, AND SIGNATURES OF PROPERTY OWNERS
- 4) DIAGRAM SHOWING GENERAL LOCATION OF SUBDIVISION
- 5) STATED AND GRAPHIC SCALE
- 6) NORTH ARROW
- 7) AT LEAST TWO (2) CORNERS OF THE SUBDIVISION SHALL BE REFERENCED TO THE STATE PLANE COORDINATE SYSTEM (IF AN ESTABLISHED AND PROVEN POINT IS WITHIN ONE HALF (0.5) MILE OF THE SUBDIVISION.
- 8) PROPERTY LINES WITH ACCURATE DIMENSIONS, BEARINGS, TANGENT DISTANCES, RADII, CENTRAL ANGLES, ARC LENGTHS, AND DEGREES OF ALL CURVES
- 9) DESCRIPTION OF ALL MONUMENTS
- 10) NUMBERS TO IDENTIFY EACH BLOCK AND LOT
- 11) AREA OF EACH LOT
- 12) TOTAL ACREAGE
- 13) PRESENT ZONING OF PROPERTY
- 14) PURPOSE OF WHICH SITES OTHER THAN RESIDENTIAL LOTS MAY BE USED
- 15) EXISTING STRUCTURES LOCATED AND DIMENSIONED SO THAT CONFORMANCE WITH ANY APPLICABLE REGULATIONS CAN BE VERIFIED
- 16) LOCATION, DIMENSIONS, AND PURPOSE OF ANY EASEMENTS
- 17) NAMES & ROW WIDTH OF EACH STREET OR OTHER PUBLIC ROW
- 18) ROW LINES OF STREETS
- 19) NAMES AND ADDRESSES OF ALL ADJOINING PROPERTY OWNERS
- 20) PRESENT ZONING OF ADJACENT PROPERTY
- 21) THE FOLLOWING NOTES REGARDING EASEMENTS:
  - a. EASEMENTS ARE PRIVATELY MAINTAINED.
  - b. STRUCTURES ARE PROHIBITED ON EASEMENTS.
  - c. ACCESS TO EASEMENTS SHALL NOT BE RESTRICTED.
  - d. NO TREES OR SHRUBS PLANTED WITHIN RIGHT-OF-WAY OR EASEMENTS UNLESS APPROVED OTHERWISE BY THE LOCAL GOVERNING AUTHORITY.
- 22) CERTIFICATION OF TITLE SHOWING THAT THE APPLICANT IS THE OWNER OF THE LAND WITHIN THE SUBDIVISION

- 23) CERTIFICATE OF THE OWNER DEDICATING STREET RIGHT-OF-WAYS AND ANY SITES FOR PUBLIC USE.
- 24) CERTIFICATE OF ACCEPTANCE BY THE CITY COUNCIL OF ANY LAND, RIGHT-OF-WAYS, OR EASEMENTS DEDICATED TO THE CITY
- 25) CERTIFICATE BY THE CITY ENGINEER AND CITY UTILITIES DIRECTOR THAT THE SUBDIVISION MEETS ALL THE REQUIREMENTS FOR REQUIRED STREET AND UTILITY IMPROVEMENTS (IF THERE ARE ANY IMPROVEMENTS)
- 26) CERTIFICATE OF APPROVAL BY COUNTY ENGINEER (IF THE SUBDIVISION IS LOCATED WITHIN THE PLANNING JURISDICTION ONLY AND NOT WITHIN THE PHENIX CITY LIMITS)
- 27) CERTIFICATE BY THE COUNTY HEALTH OFFICER (WHEN INDIVIDUAL SEWAGE DISPOSAL AND/OR WATER SYSTEMS ARE INSTALLED IN LIEU OF PUBLIC SYSTEMS)
- 28) CERTIFICATE BY THE PLANNING COMMISSION THAT THE FINAL PLAT HAS BEEN APPROVED
- 29) CERTIFICATE FROM CORRESPONDING UTILITY JURISDICTION IF ANY UTILITIES SHOWN ON PLAT DO NOT BELONG TO THE CITY OF PHENIX CITY OR ARE NOT UNDER THE JURISDICTION OF THE CITY OF PHENIX CITY
- 30) STATEMENT BY A LAND SURVEYOR REGISTERED IN THE STATE OF ALABAMA CERTIFYING THE PLAT

The original and six (6) black and white copies of the plat along with the completed Petition must be presented to the Planning Commission Recording Secretary at least ten (10) days prior to the Planning Commission meeting which it is to be considered. The complete legal description and adjoining property owners' names and addresses must also be submitted on paper and on a CD. The sheet size for the plat shall be a minimum of eighteen inches (18") by twenty-four (24") and not larger than twenty-four (24") by thirty-six (36"). There is a \$100.00 filing fee, which must be paid when all required documents are submitted.

\*The Planning Commission meets on the second (2<sup>nd</sup>) and fourth (4<sup>th</sup>), Tuesdays of each month at 5:15pm EST.

\*All survey data and accompanying plats or drawings shall be according to the Standards of Practice for Land Surveying in the State of Alabama, Latest Edition, as published by the Alabama Society of Professional Land Surveyors.



**APPENDIX 1B**  
**PETITION FOR SUBDIVISION**

DRAFT

DRAFT

**Petition for Subdivision**

**(Please Print OR Type Information Clearly)**

Name of Subdivision: \_\_\_\_\_

Location: \_\_\_\_\_

Number of Lots: \_\_\_\_\_

Current Zoning Classification: \_\_\_\_\_

Number of Adjacent Lots: \_\_\_\_\_

Current Zoning Classification of Adjacent Property: \_\_\_\_\_

Name of Owner: \_\_\_\_\_

Address of Owner: \_\_\_\_\_

Telephone Number(s) of Owner: \_\_\_\_\_

Email Address of Owner: \_\_\_\_\_

Signature of Owner: \_\_\_\_\_

**(DO NOT WRITE BELOW THIS LINE)**

**Fees:**

\$100.00 Base Filing Fee

\$5.00 + Current Postal Rate x \_\_\_\_\_ = \$ \_\_\_\_\_ (Adjacent Property Owners – Certified Letters)

Total Amount Due: \$ \_\_\_\_\_

Cash: \_\_\_\_\_

Check: \_\_\_\_\_

Collected By: \_\_\_\_\_

DRAFT

**THE FOLLOWING INFORMATION MUST BE SHOWN ON ALL PRELIMINARY PLATS TO BE SUBMITTED  
FOR A SUBDIVISION.**

- 1) A vicinity map showing the location of the proposed subdivision and its relationship to the surrounding area.
- 2) Survey data showing the dimensions of the boundaries of the subdivision; section and corporate lines; and contours at five (5) foot intervals based on the National Geodetic Survey Datum or North American Vertical Datum of 1988, unless required by the City Engineer to submit contours at lesser intervals. In some cases the City Engineer may require a boundary survey of the subdivision and spot elevations in sufficient number to provide necessary drainage information.
- 3) The title or name under which the proposed subdivision is to be recorded; the name and address of the owner or owners; and the name of the registered land surveyor responsible for the plat.
- 4) Notations giving the scale of the drawing(s), true north arrow, datum, benchmarks, bearing base, and date.
- 5) The location of existing streets, buildings, railroads, bridges, sanitary sewers, drainage facilities, water mains, and any public easements on both the land being subdivided and on the adjoining land; the names of adjoining subdivisions; and the names and mailing address of the owners of record of the adjoining parcels of land as they appear on the current tax records in the office of the Tax Assessor of Russell County or Lee County.
- 6) The location of proposed streets, right-of-way widths, alleys, easements, parks, open spaces, and reservations.
- 7) Lot lines, lot numbers, building setback lines; tabulations stating gross and net acreage of the subdivision, acreage of existing and proposed public areas within the subdivision, number of residential lots, and area of smallest lot.
- 8) The location of watercourses, 100-year floodplains, wetlands, wooded areas, buildings or structures, and other significant natural and built features on the tract.
- 9) Information about highways or other major public improvements planned by public authorities for future construction on or adjacent to the tract.
- 10) Sites to be reserved or dedicated for parks, recreation areas, schools or other public uses; sites, if any, for multi-family dwellings, shopping centers, churches, industry, or other uses exclusive of single family dwellings.

- 11) Additional information as required by the City Engineer, such as profiles and cross sections of existing and proposed streets, drainage features, utility tie-ins, etc., in order to determine the feasibility of the proposed subdivision.
- 12) Streams, wetlands and other jurisdictional waters on site and within 25 feet of potential Waters of the United States shall be delineated by an Environmental Professional and surveyed in the field and indicated on the Preliminary Plat. If no streams, wetlands, or other Jurisdictional Waters of the United States, the Environmental Professional shall provide a statement indicating the results.

The Subdivider shall file with the Planning Commission Recording Secretary five (5) black and white or blue line copies of the Preliminary Plat, a completed Subdivision Petition, a complete legal description on computer disk, a list of names and mailing addresses of all adjoining property owners, at least ten (10) business days prior to the Planning Commission meeting at which it is to be reviewed for acceptance. Prior to Planning Commission review, the Preliminary Plat shall be reviewed by all appropriate City Departments. The review shall take into consideration, in addition to the requirements set out in these regulations, conformance of the subdivision design to the Comprehensive Plan and the particular requirements and conditions affecting installation of improvements.

The Preliminary Plat shall be drawn at a scale of one inch equals one hundred (100) feet, or other appropriate scale as approved by the City Engineer. The sheet size shall be a minimum of eighteen inches (18") by twenty-four inches (24") and not larger than twenty-four inches (24") by thirty-six inches (36"). Where necessary the Preliminary Plat may be presented on several sheets accompanied by an index sheet showing the entire subdivision. There is a \$100.00 filing fee and a \$5.00 Certified Letter fee plus the current postal rate for each adjacent property owner of the proposed subdivision, which must be paid when all required documents are submitted.

\*The Planning Commission meets on the second (2nd) and fourth (4th), Tuesdays of each month at 5:15pm EST.

\*All survey data and accompanying plats or drawings shall be according to the Standards of Practice for Land Surveying in the State of Alabama, Latest Edition, as published by the Alabama Society of Professional Land Surveyors.

**THE FOLLOWING INFORMATION MUST BE SHOWN ON ALL FINAL PLATS TO BE SUBMITTED FOR A SUBDIVISION.**

- 1) A diagram to scale showing the general location of the subdivision.
- 2) Primary control points approved by the City Engineer or County Engineer, as appropriate; or description and ties to such control points; to which all dimensions, angles, bearings, and similar data on the plat shall be referred.
- 3) Tract boundary lines, right-of-way lines of streets, easements and other right-of-ways; property lines of lots and other sites with accurate dimensions; bearings, tangent distances, radii, central angles, arc lengths, and degrees of all curves; and the location and description of all monuments. All survey data and accompanying plats or drawings shall be according to the Standards of Practice for Land Surveying in the State of Alabama, latest edition, as published by the Alabama Society of Professional Land Surveyors. At least two (2) corners of the subdivision shall be referenced to the State Plane Coordinate System (North American Datum of 1983 – Alabama East Zone) if an established and proven point is within one half (0.5) mile of the subdivision.
- 4) Title, stated and graphic scales, north arrow, and date.
- 5) Name and right-of-way width of each street or other public right-of-way.
- 6) Numbers to identify each block and lot; and the area of each lot.
- 7) The location, dimensions, and purpose of any easements.
- 8) The purpose for which sites other than residential lots may be used.
- 9) Names of adjoining property owners.
- 10) Existing structures shall be located on the plat and fully dimensioned so that conformance with any applicable regulations can be verified.
- 11) The following notes regarding easements:
  - a. Easements are privately maintained.
  - b. Structures are prohibited on easements.
  - c. Access to easements shall not be restricted.
  - d. No trees or shrubs planted within right-of-way or easements unless approved otherwise by the local governing authority.
- 12) Certificate of title showing that the applicant is the owner of the land within the subdivision.

- 13) Certificate of the owner dedicating street right-of-ways and any sites for public use. See Certificates in Appendix for example.
- 14) Statement by a Land Surveyor registered in the State of Alabama certifying that the plat meets the requirements of the Standards of Practice for Land Surveying in the State of Alabama, latest edition, as published by the Alabama Society of Professional Land Surveyors.
- 15) Certificate of approval by the County Engineer if the subdivision is located with the Planning Jurisdiction only and not within the Phenix City Limits.
- 16) Certificate of acceptance by the City Council of any land, right-of-ways, or easements dedicated to the City.
- 17) Certificate by the City Engineer and City Utilities Director that the subdivision meets all the requirements for required street and utility improvements.
- 18) Certificate by the County Health Officer when individual sewage disposal and/or water systems are to be installed. This certificate will only be required when a private sanitary collection system has been installed in lieu of a public sanitary sewer system.
- 19) Certificate by the Planning Commission that the Final Plat has been approved.
- 20) Certificate from corresponding utility jurisdiction if any utilities shown on plat do not belong to the City of Phenix City or are not under the jurisdiction of the City of Phenix City.
- 21) The Final Plat shall be accompanied by the following items, as appropriate:
  - a. A Performance Bond with a Commercial Surety or an irrevocable Letter of Credit, from a preapproved bank which has an investment grade rating. The Performance Bond or Letter of Credit shall be in an amount equal to one hundred fifty (150) percent of the estimated cost of all incomplete improvements, provided there is adequate infrastructure approved by the City Engineer in place to adequately serve the lots with streets, drainage, sewer, water, and fire protection. The incomplete improvements that may be covered by the Performance bond include non-infrastructure related improvements such as general site erosion control measures, construction of sidewalks, street lights, and erosion control specifically related to the repair of disturbed areas as utilities are installed (not including sewer, water, and storm). All incomplete improvement bonds must be preapproved by the City Engineer. An estimate of the incomplete improvements must be submitted by a licensed engineer and approved by the City Engineer prior to submission of the Performance Bond or Letter of Credit. The City reserves the right to refuse at its sole discretion the issuing bank.



- b. A Performance Bond, or an irrevocable Letter of Credit per (a) above, in the amount of one hundred percent (100%) of the estimated cost of the final wearing surface of asphalt. The final wearing surface shall be placed within one year of the date of Final Plat. A maximum of one (1) extension of twelve (12) months may be granted.
- c. A Maintenance Bond, or an irrevocable Letter of Credit per (a) above, in the amount of twenty-five percent (25%) of the estimated cost of the improvements to ensure compliance with the two (2) year warranty. The two (2) year maintenance bond period shall begin from the date of acceptance by the City. Any Bond or Letter of Credit shall include an "evergreen" clause to include automatic renewal until released by the City of Phenix City. A maximum of one (1) extension of twelve (12) months may be granted.
- d. A copy of the protective covenants, if any, as they are to be recorded. If the subdivision contains common open space or other amenities for the use of the residents of the subdivision, provisions shall be made for a homeowner or residents association. If the subdivision contains drainage features such as detention ponds or open space, a perpetual maintenance fund shall be established and used by the Home Owners Association for maintenance items such as landscaping, mowing, fence repair, etc. For any subdivision containing a detention pond or open space, a copy of covenants must be provided detailing the creation of a Home Owners Association as well as the creation and sustainment of the perpetual maintenance fund. The City of Phenix City retains the right to maintain the drainage infrastructure of the detention pond in efforts to encourage proper drainage. All detention ponds, associated structures, and systems require drainage easements. If the City of Phenix City does need to perform maintenance on the detention pond(s) within the drainage easements, the City retains the right to bill the maintenance costs to the Subdivision's Home Owners Association and perpetual maintenance fund. In the absence of a Home Owners Association, each property owner within the subdivision shall be assessed the cost of maintenance by the City of Phenix City.
- e. Receipt of a certificate from a Land Surveyor registered in the State of Alabama that permanent monuments of suitable size and material have been placed for each lot corner in the subdivision, and that a satisfactory survey defines such permanent monuments in relation to located section corners or fractional corners of the Survey of Public Lands.
- f. A breakdown of final quantities, including costs, prepared by a licensed engineer of the following items: water lines, sewer lines, storm drain pipe, curb and gutter, sidewalks, and pavement (linear feet).

- g. Certification by the Design Engineer ensuring subdivision has accurately been designed and constructed in accordance with the requirements set forth in the Phenix City Subdivision Regulations and with the approved construction plans for the subdivision.
- h. Certification by the Design Engineer ensuring stormwater drainage system of the subdivision has accurately been designed and constructed in accordance with the requirements set forth in the Phenix City Subdivision Regulations.

The Final Plat and As-built Survey shall be drawn at a scale of one-inch equals one hundred feet, or other appropriate scale as approved by the City Engineer. The sheet size shall be a minimum of eighteen inches (18") by twenty-four inches (24") and not larger than twenty-four inches (24") by thirty-six inches (36"). The Final Plat shall also be submitted on a computer disk using a GIS format.

The As-built Survey shall consist of the storm sewer layout with invert elevations, pipe sizes, and pipe materials; the sanitary sewer layout with invert elevations, pipe sizes, and pipe materials; the water line layout with pipe sizes, and pipe materials; and a combined utilities and storm layout showing horizontal and vertical clearances. Each layout shall be on a separate sheet with "As-built Survey" written on each sheet. The "As-built Survey" is subject to the Standards of Practice for Surveying in the State of Alabama. The As-built Survey shall have a certification from a Licensed Surveyor in the State of Alabama and be signed and sealed by said Surveyor. The As-built Survey shall also be submitted on a computer disk using a CAD/GIS format such as a Shapefile, DGN, or DWG. Files are preferred in state plane coordinates. If GIS formatting in state plane coordinates cannot be provided, a CAD file including horizontal dimensioning to all valves, hydrants, fittings, etc., can be submitted using references such as permanent monuments on property corners, right-of-way markers, or other physical and permanent markers.

One (1) original and five (5) black and white or blue line copies of the Final Plat and four (4) black and white or blue line of the As-built Survey shall be submitted to the Planning Commission Recording Secretary at least ten (10) business days prior to the Planning Commission meeting which it is to be considered.

\*The Planning Commission meets on the second (2nd) and fourth (4th), Tuesdays of each month at 5:15pm EST.

\*All survey data and accompanying plats or drawings shall be according to the Standards of Practice for Land Surveying in the State of Alabama, Latest Edition, as published by the Alabama Society of Professional Land Surveyors.

**APPENDIX 1C**  
**PETITION FOR CONDITIONAL USE**

DRAFT

DRAFT

**Petition For Conditional Use**

Date: \_\_\_\_\_

Signature of Property Owner/or Authorized Agent of the Property

Owner: \_\_\_\_\_

Address of Property to Be Considered For Conditional Use:

\_\_\_\_\_

Phone: ( \_\_\_\_\_ ) \_\_\_\_\_

Current Zone: \_\_\_\_\_

Proposed Use of Property: \_\_\_\_\_

\_\_\_\_\_

***Provide A List Of Adjacent Property Owners' Names And Mailing Addresses With A Fee Of \$5.00 Plus Current Postal Rate, Per Name. (This Requires a Public Hearing)***

**In Addition To The Above Information You Need To Submit A Site Plan And Be Prepared To Answer Questions Concerning:**

- A. Access to and from the property and the proposed structure and/or uses, with particular attention to vehicular and pedestrian safety and convenience, traffic flow and control, and emergency access.
- B. The location and accessibility of off-street parking and loading areas.
- C. The location and accessibility of refuse and service areas and their potentially adverse effects upon surrounding properties.
- D. The screening and buffering of potentially adverse views and activities from surrounding properties.
- E. Control of noise, glare, odor, surface water runoff, and other potentially disturbing impacts upon surrounding properties.
- F. The availability, location, and capacity of utilities.
- G. The location and scale of signs and lighting with particular reference to traffic safety, glare, and visual compatibility with surrounding properties.
- H. The bulk, density, and lot coverage of structures, and yards and open areas, with reference to their compatibility with the character of the surrounding area.

**CONTACT THE BUILDING DEPARTMENT 448-2740**

DRAFT

**APPENDIX 1D**  
**LAND DISTURBANCE PERMIT APPLICATION AND CHECKLIST**

DRAFT

DRAFT





# LAND DEVELOPMENT PERMIT APPLICATION

ENGINEERING AND PUBLIC WORKS DEPARTMENT

1201 7<sup>th</sup> Avenue, 2<sup>nd</sup> Floor

Phenix City, AL 36867

334-448-2760 ~ [EngineeringPW@phenixcityal.us](mailto:EngineeringPW@phenixcityal.us)

## PROJECT INFORMATION

Applicant Name: \_\_\_\_\_ Project Name: \_\_\_\_\_

Mailing Address: \_\_\_\_\_ Project Address: \_\_\_\_\_

Phone Number: \_\_\_\_\_ Property Acreage: \_\_\_\_\_

Disturbed Acreage: \_\_\_\_\_

Email Address: \_\_\_\_\_ Current Zoning: \_\_\_\_\_

## PROPERTY OWNER INFORMATION

Owner Name: \_\_\_\_\_ Mailing Address: \_\_\_\_\_

Phone Number: \_\_\_\_\_

Email Address: \_\_\_\_\_

**A COPY OF THE DEED TO THE SUBJECT PROPERTY MUST BE SUBMITTED WITH THIS APPLICATION.** If the developer is not the owner, then a letter of designation allowing the developer to act as an “authorized agent” must be on file. All associated fees will be charged to the developer unless otherwise arranged.

## ENGINEER OF RECORD

Engineer Name: \_\_\_\_\_ Mailing Address: \_\_\_\_\_

Phone Number: \_\_\_\_\_

Email Address: \_\_\_\_\_

**Land Development Permit Application must be accompanied by completed Land Development Permit Submittal Checklist and required documentation.**

*I, the developer, certify that all of the above facts are true and correct to the best of my knowledge. I understand that a development approval(s) granted pursuant to the application shall be subject to all applicable regulations of the City of Phenix City, and that such approval(s) shall expire unless construction has commenced within eighteen (18) months following date of approval.*

Developer's Signature: \_\_\_\_\_

Developer's Name (Please Print): \_\_\_\_\_

Date: \_\_\_\_\_

DRAFT



# LAND DEVELOPMENT PERMIT SUBMITTAL CHECKLIST

ENGINEERING AND PUBLIC WORKS DEPARTMENT

1201 7<sup>th</sup> Avenue, 2<sup>nd</sup> Floor

Phenix City, AL 36867

334-448-2760 ~ [EngineeringPW@phenixcityal.us](mailto:EngineeringPW@phenixcityal.us)

Project Name: \_\_\_\_\_ Engineer of Record: \_\_\_\_\_

This checklist must be submitted with every Land Development Permit Application. All items on the checklist shall be addressed. If the item is not applicable to this project, check the box next to the item labeled "N/A", and provide comment. **If one of these items is missing from the submittal without a valid explanation, the entire submittal will be rejected.** Note that this checklist is not intended to be all inclusive, and fulfillment of this checklist does not alleviate the obligation of the designer to meet all City of Phenix City codes, regulations, ordinances, and specifications. The purpose of this checklist is to facilitate a more efficient plan review process for the designer and the review team.

Description	Check	N/A	Comments
<b>Construction Plans</b>			
These are the basic sheets we expect to see in a set of plans. Some sheets may be combined on certain projects, or have different names (for example, water and sewer shown on one utility plan sheet for small projects). For a comprehensive checklist of items to be shown on each sheet, please see the <b>Construction Plan Review Checklist</b> .			
Title/Cover Sheet			
Project Notes			
Existing Conditions/Demo Plan			
Site Plan (Engineering)			
Water Plan			
Sanitary Sewer Plan			
Sanitary Sewer Profiles			
Grading & Drainage Plan			
Storm Sewer Profiles			
Erosion & Sediment Control Plan			
Street Plan & Profiles (for public infrastructure)			
Misc. Details, Cross-sections & Other Sheets			
City of Phenix City Standard Details (Water, Sanitary Sewer, Storm Sewer, etc.)			
<b>Forms</b>			
Application for Installation of Underground Utility Permit			
Permit to Construct a Turnout to Provide Access to a City Street			
ALDOT Turnout Permit			
ALDOT Utility Permit			
Authorized Agent Form			
Grease Removal Device Sizing Worksheet			
NPDES Application			
NPDES Permit			

DRAFT

<b>Misc. Required Items</b>			
Stormwater Management Report			
USGS Map			
As-Built CAD Files of Public Infrastructure at completion of project. (See <b>CAD File Submittal Guide</b> for required items.)			<b>Must be submitted to the Phenix City Engineering Department prior to issuance of the Certificate of Occupancy.</b>
<b>Permit Fee (Based on site area. Check the one that applies.)</b>			
0 - 5 acres	\$65		
5 - 10 acres	\$95		
10 - 25 acres	\$125		
25 - 50 acres	\$155		
50 - 75 acres	\$185		
75 - 100 acres	\$215		
Greater than 100 acres	\$245		

**SIGNED:** \_\_\_\_\_  
 (ENGINEER OF RECORD)

DRAFT

DRAFT



# CONSTRUCTION PLAN REVIEW CHECKLIST

ENGINEERING AND PUBLIC WORKS DEPARTMENT

1201 7<sup>th</sup> Avenue, 2<sup>nd</sup> Floor

Phenix City, AL 36867

334-448-2760 ~ [EngineeringPW@phenixcityal.us](mailto:EngineeringPW@phenixcityal.us)

Description	Check	N/A
<b>Title Sheet</b>		
Project Title		
Permit Numbers (USACE & ADEM)		
Relevant Contact Information		
Sheet Index		
Vicinity Map (legible)		
Engineer's Seal		
<b>Project Notes</b>		
Verify that project notes do not conflict with City of Phenix City specifications		
Provide Legend		
<b>Existing Conditions/Demo Plan</b>		
Include North arrow		
Show locations of existing structures		
Indicate if structures are being removed		
Show existing topography with clearly labeled contours lines		
Minimum 2ft contour intervals with every 10ft line labeled		
Show existing water features including wetland areas		
Show existing easements and right-of-ways		
Show existing utilities		
Indicate if being removed/abandoned		
Show all property lines		
Show the limits of clearing & grubbing		
<b>Site Plan (engineering)</b>		
Show property lines, building layout, pavement, traffic/parking striping, traffic signs, etc.		
Indicate parking dimensions, lane widths, and corner radii		
Show dumpster location		
Verify Planning Commission resolutions have been met for Conditional Uses		
<b>Water Plans</b>		
*Required water service submittals prior to or with plan submittal:		
Development Application for Water and Sewer Service		
Backflow Protection Information Sheet		
Fire flow calculations (where applicable, coordinate with the WRM Department)		
Include North arrow		
If water layout requires multiple pages, include an overall plan sheet		
The following <b>existing</b> water infrastructure should be shown:		

Location, size, and material of all water mains and service lines		
Location and size of all water meters		
Location of the nearest main line valves for isolation of the site		
Location of the nearest fire hydrants		
Location of all blow-off valves and air release valves		
The following <b>proposed</b> water infrastructure should be shown:		
Location, size, and material of all water mains and service lines		
Location and size of all water meters (place at edge of ROW or easement)		
Location of all isolation valves, blow-off valves, and air release valves		
Location of all fire hydrants		
Location of FDC within 125 ft of a fire hydrant		
Location of all backflow prevention devices, and vaults		
Location of all bends, tees, and fittings (specify type and degree)		
Location and detail of all necessary thrust restraint		
Location of vault drain to grade or to storm sewer		
Show all existing and proposed easements		
Provide a general layout of other utilities (existing and proposed)		
Clearly differentiate between existing and proposed utilities		
Detail all main line connections showing appropriate tap configuration and fittings		
Provide backflow prevention for all main line connections		
Provide estimated static pressure (normally 820 - FFE / 2.31)		
Use pressure reducing valves where static pressure > 70 psi		
Size pipes to maintain a velocity not to exceed 10 ft/sec		
Provide minimum cover of 30 inches for lines 8 inches and smaller		
Provide minimum cover of 36 inches for lines larger than 8 inches		
Provide minimum 18 inches vertical separation where water & sewer cross		
Provide minimum 10 feet horizontal separation between water & sewer lines		
Provide sprinkler count		
Provide the following notes where applicable:		
"Existing services to be abandoned shall be terminated at the main."		
"Notify AWWB of any scheduled outages 7 days prior to the outage."		
"Only AWWB personnel are authorized to operate AWWB valves."		
<b>Sanitary Sewer Plans</b>		
*Required sewer service submittals prior to or with plan submittal:		
Development Application for Water and Sewer Service		
Grease Trap Sizing Worksheet		
Approved pump station design (coordinated with the PC Utilities Department)		
Include North arrow		
If sewer layout requires multiple pages, include an overall plan sheet		
Show all existing and proposed easements		
Provide a general layout of other utilities (existing and proposed)		
The following <b>existing</b> sewer infrastructure should be shown:		
Location of all manholes with rim, and all invert elevations provided		
Location, sizes, materials, and slopes of all sewer mains and laterals		



Location, and size of grease traps and/or oil & grit separators		
The following <b>proposed</b> sewer infrastructure should be shown:		
Location of all manholes with rim, and all invert elevations provided		
Location, sizes, materials, and slopes of all sewer mains and laterals		
Location and size of grease traps where required		
Location and size of oil & grit separators where required		
Location of cleanouts at the edge of ROW or easement		
Clearly differentiate between existing and proposed utilities		
Label all manholes and pipes (correspond with labels on profile sheets)		
Provide contours or specify finish floor elevations		
Indicate how existing sewer mains or services are to be abandoned		
Manholes shall be locked down if less than 1 foot above the 100-yr BFE		
<b>Public</b> sanitary sewer main requirements:		
Manholes shall be located in the center of the street where possible		
Design sewer lines for maximum capacity at half full		
DIP required where cover is greater than 12 feet or less than 3 feet		
DIP required where less than 2 feet of clearance between utilities		
DIP required within the 100-yr BFE or where buoyancy is a concern		
Provide consistent pipe material between manholes		
Minimum slope requirements:		
4"=2%		
6"=1%		
8"=0.60%		
10"=0.35%		
12"=0.30%		
Provide a minimum 0.10' drop across all straight through manholes		
Provide a minimum 0.25' drop across all turning manholes		
Manhole spacing should not exceed 400 feet		
Services tied into mains shall have a 3 feet minimum separation		
Service lines should connect to manholes where possible		
Use standard 4 inch drop for service lines into manholes		
Service lines angled against the flow use a minimum 6 inch drop		
If angle against the flow >135 degrees connect lateral directly to main		
No more than four laterals connected to a pass through manhole		
No more than five laterals connected to a beginning manhole		
Cleanouts to be located in traffic rated enclosure in paved areas		
Backflow prevention is required when any served portion of a building is less than 12 inches above the rim elevation of the nearest <b>upstream</b> manhole. Such lots shall be identified on the plans and the plat.		
<b>Sanitary Sewer Pipe Profiles</b>		
Indicate pipe material, size, slope and length		
Show all utility crossings		
Show existing and proposed grades		
Show all rim and invert elevations		
Show outside drop manhole where drop is 2 feet or greater		

Label all manholes and pipes (correspond with labels on plan sheets)		
Show existing mains and structures at all connection points		
Clearly differentiate between existing and proposed utilities		
Clearly differentiate between material types		
<b>Grading and Drainage Plans</b>		
Include North arrow		
If plans require multiple pages, include at least one overall plan sheet		
Show existing topographic contours		
Maximum 2ft contour intervals with every 10ft line labeled		
Used lighter or dashed line type for existing contour lines		
Show proposed contours		
Maximum 2ft contour intervals with every 10ft line labeled		
Proposed contour lines should tie-in to existing contour lines		
Show streams and other water features		
Show stream & wetland buffers		
Show 100-yr flood plain boundaries		
Indicate minimum FFE's for lots adjacent to water features		
Show all existing structures, utilities, and easements that will remain		
Show mitigation areas		
Indicate steep slopes (City of Phenix City Erosion and Sediment Control Ordinance)		
Show curb & gutter (2ft City of Phenix City Std. C&G)		
Show all storm water inlets		
Max access spacing 500ft for 15in to 48in pipe (for public infrastructure)		
Max access spacing 800ft for 54in or greater (for public infrastructure)		
Double-wing inlets only used in sags (for public infrastructure)		
Show all proposed culverts		
Indicate type and dimensions		
Show headwalls and energy dissipaters		
Show all storm sewer pipe		
Show headwalls at discharge points		
Show all manholes and junction boxes		
Extend discharge points at least 10 ft beyond building lines		
Show rip-rap or other energy dissipaters at discharge points		
Show all proposed drainage & utility easement		
Show detention system(s)		
Fencing required around ponds		
Pipes discharge at bottom of pond slopes		
Show outlet structure(s)		
<b>Storm Water Pipe Profiles</b>		
Indicate pipe size, material, slope and length		
Pipe within ROW shall be RCP		
Show rim & invert elevations		
Show 25-yr Hydraulic Grade Line		
Show existing and proposed grades		

Show all other utility crossings		
Show existing pipe & structures at tie-ins		
<b>Erosion and Sediment Control Plans</b>		
Used a phased plan when applicable		
Show clearing limits		
Show 25' (per E & SC Ord.) stream & wetland buffers. Drainage basin of stream should be delineated from the commencement point of the stream, to the point that it leaves the property.		
Provide an ES&C legend		
Identify project sign location and provide project rain gauge on site		
Silt fencing shall be Class "A" (wire reinforced, metal staked, trenched) or C-POP		
Construction Entrance Pad (min 20ft x 50ft) Use #1 stone with geotextile fabric underneath. One CEP per site at any given time.		
Hay bales may not be used as stand-alone inlet protection. They can be used in conjunction with silt fence, silt savers, etc		
Use rock check dams, wattles, or silt fence check dams (rather than hay bales) where applicable.		
Design and show outlet protection at all discharges		
Show curb inlet protection devices (no stand-alone hay bales)		
Slopes greater than 3:1 require a waiver approved by the City Engineer. If approved, erosion control blankets will be required. Specify types of blankets being used.		
Show all sediment basin locations, filter structures, and sediment volumes		
*Submit sediment storage calculations		
Attach City of Phenix City standard erosion & sedimentation ctrl. details		
Include the following notes on the E&SC Plans:		
<i>a. Any area that has been disturbed and will remain so for more than 13 days shall be seeded and mulched within 5 days of being disturbed.</i>		
<i>b. Additional BMPs may be required by the QCP and/or City of Phenix City over the course of the project to minimize sediment release from the site</i>		
<i>c. All BMPs shall be designed and installed in accordance with the Alabama Handbook for Erosion Control, Sediment Control, and Storm water Management on Construction Sites and Urban Areas and the City of Phenix City standard erosion and sediment control details.</i>		
<i>d. The use of floc-blocks, polyacrylamide (PAM), or other settling enhancement materials may be required by the QCP or City of Phenix City during the course of construction to minimize turbidity and sediment release from the site.</i>		
<b>Street Plan &amp; Profiles (for public infrastructure only)</b>		
<b>Plan view</b>		
Include North arrow		
Show existing and proposed topography		
Show edge of pavement and curb/gutter		
Show ROW & easements		
Show station line		
Show horizontal curve radii		
Indicate tangent lengths (minimum 100ft between curves)		
Indicate street width (b/c to b/c)		
Indicate intersection corner property line radii (minimum 20ft)		
Show proposed sidewalks		

<b>Profile View</b>		
Show existing and proposed centerline grades		
Max grade for local streets = 15%		
Max grade for collector streets = 12%		
Max grade for minor arterial = 8%		
Max grade = 5% within 100ft of intersection		
Show vertical alignment with all vertical curve data		
Indicate the design speed used		
Local Street Design Speed = 25 mph		
Collector Street Design Speed = 35 mph		
Align stationing with the plan view station line		
<b>Miscellaneous Details, Cross-sections, &amp; Other Sheets</b>		
Collector or arterial (or other special) striping		
Show details for improvements to off-site infrastructure:		
Turn lanes - including buildup and striping (meet with City on widening)		
Off-site sewer, water, or storm water improvements		
Detention outlet control structure details		
Culvert details		
HDPE installation details		
Tail ditch and/or swale details		
Traffic control plan and detour plan		
Proposed street classifications & buildups (for public infrastructure)		
<b>City of Phenix City Standard Details</b>		
Include all relevant City of Phenix City standard details with the final plans		
<b>Miscellaneous Design Requirements</b>		
No trees within 10ft of center line of utilities		
Sight distance analysis needed?		
Storage/taper length calculations for turn lanes? (can be shown on plans)		
Are any waivers or variances required?		
The following note should be added to all utility plans and plats		
<i>No permanent structures may be constructed or placed on easements. Fences may be erected perpendicular across the easement provided there is a minimum 20-foot wide access gate installed. If the gate is to be locked there must be a City-approved lock installed in conjunction with the owners lock. No trees shall be planted within 10 feet of utilities.</i>		
Easements shall be the greater of 20ft or 2 times the depth to the bottom of the utility. Easement widths shall be in increments of 10ft.		
Slope and grades of easements shall be passable by vehicles (maximum easement cross slope of 4:1)		
All topography should be relative to MSL (no assumed datum)		
Utility stub outs for future development should be placed in easements extending to the edge of the property line		
There are no points of storm water discharge from the property that exceed the pre-development conditions at those points		



# LAND DEVELOPMENT PERMIT AUTHORIZED AGENT FORM

ENGINEERING AND PUBLIC WORKS DEPARTMENT  
1201 7<sup>th</sup> Avenue, 2<sup>nd</sup> Floor  
Phenix City, AL 36867  
334-448-2760 ~ [EngineeringPW@phenixcityal.us](mailto:EngineeringPW@phenixcityal.us)

## PROPERTY OWNER

I, \_\_\_\_\_, being owner of the property which is the subject of this application \_\_\_\_\_ hereby authorize \_\_\_\_\_ to act as my representative with the City of Phenix City, as required by the type of request listed on the attached Land Development Application.

Property Owner's Signature: \_\_\_\_\_

Date: \_\_\_\_\_

STATE OF ALABAMA | COUNTY OF RUSSELL

I, \_\_\_\_\_, a Notary Public in and for said State at Large, hereby certify that \_\_\_\_\_, who is named as

\_\_\_\_\_, is signed to the foregoing document, and:

Who is known to me, or

Whose indentity I proved on the basis of \_\_\_\_\_, or

Whose identity I proved on the oath/affirmation of \_\_\_\_\_, a

credible witness to the signer of the above document and that being informed of the contents of the document, he/she, as such officer and with full authority, executed the same voluntarily on the day the same bears date.

Given under my hand and official seal this the \_\_\_\_\_ day of \_\_\_\_\_, 20 \_\_\_\_\_

Notary Public

Commission Expiration

DRAFT



# LAND DEVELOPMENT PERMIT AUTHORIZED AGENT FORM

ENGINEERING AND PUBLIC WORKS DEPARTMENT  
1201 7<sup>th</sup> Avenue, 2<sup>nd</sup> Floor  
Phenix City, AL 36867  
334-448-2760 ~ [EngineeringPW@phenixcityal.us](mailto:EngineeringPW@phenixcityal.us)

## PROPERTY OWNER

I, \_\_\_\_\_, being owner of the property which is the subject of  
this application \_\_\_\_\_ hereby authorize

\_\_\_\_\_ to act as my representative with the City of Phenix City, as  
required by the type of request listed on the attached Land Development Application.

Property Owner's Signature: \_\_\_\_\_

Date: \_\_\_\_\_

STATE OF ALABAMA | COUNTY OF LEE

I, \_\_\_\_\_, a Notary Public in and for said State at Large, hereby  
certify that \_\_\_\_\_, who is named as

\_\_\_\_\_, is signed to the foregoing document, and:

Who is known to me, or

Whose indentity I proved on the basis of \_\_\_\_\_, or

Whose identity I proved on the oath/affirmation of \_\_\_\_\_, a

credible witness to the signer of the above document and that being informed of the contents of  
the document, he/she, as such officer and with full authority, executed the same voluntarily on the  
day the same bears date.

Given under my hand and official seal this the \_\_\_\_\_ day of \_\_\_\_\_, 20 \_\_\_\_\_

Notary Public

Commission Expiration

DRAFT





# CAD File Submittal Guideline

ENGINEERING AND PUBLIC WORKS DEPARTMENT  
1201 7<sup>th</sup> Avenue, 2<sup>nd</sup> Floor  
Phenix City, AL 36867  
334-448-2760 ~ [EngineeringPW@phenixcityal.us](mailto:EngineeringPW@phenixcityal.us)

## Goal:

**Standardize the information submitted by consulting and in-house engineers for more efficient processing into the City of Phenix City GIS.**

## General:

- CAD Files should be submitted as DWG (AutoCAD 2017 or prior).
- Items should be separated onto different layers / levels with logical names to allow simple interpretation of infrastructure components.
- Labels should be clearly noted.
- CAD files should be in Alabama State Plane –East Zone Coordinate system.
- \*CAD files should utilize NAVD88 vertical datum.

*\*Note: Exceptions may be allowed for projects that do not include Sanitary Sewer or Storm Sewer to be accepted by the City of Phenix City for maintenance.*

At a minimum, the following shall be infrastructure items to be included in the CAD files. Phenix City Engineering may ask for additional items.

### Sanitary Sewer

- Main Line (label size and material)
- Manholes (top and invert elevations)
- Force Main Line (label size and material)
- Low Pressure Force Mains (label size and material)
- Valves [label type of valve Combination Air Valve (CAV), Air Vacuum Valve (AVV), Air Release Valve (ARV)]
- Lift Stations
- Lateral Locations (label size and material)
- Easements

### Sidewalks

- Sidewalks to be maintained by the City of Phenix City
- Accessible Ramps

### Water Distribution System

- Water Main (label size and material)
- Water Meters (label size)
- Water Service Lines (label size and material)
- Backflow Preventer (not required for meter set assemblies)
- Fire Hydrants
- Valves (label size and type)
- Fittings (description)
- Easements

### Drainage

- Storm Pipe (label size and material)
- Storm Structures (label type, top elevation, and invert elevations)
- Pipe End Treatments (label type and size)
- Detention Ponds (Boundary)
- Permanent Water Quality BMPs (Description)
- Easements

DRAFT

**APPENDIX 1E**  
**PETITION FOR REZONE**

DRAFT

DRAFT

**THE FOLLOWING INFORMATION MUST BE SHOWN ON ALL PLATS TO BE SUBMITTED FOR REZONING**

1. Name, Address, and signature of property owners
2. Proof of ownership (deed or current tax assessment)
3. Name and address of all adjoining property owners
4. Name and address of Licensed Surveyor, including seal
5. Property Lines
6. Dimensions
7. Right-Of-Way
8. Existing Easements
9. Street Names
10. Present Zoning of property
11. Present Zoning of adjacent property
12. Present Zoning of adjacent property
13. Date
14. North arrow
15. Graphic Scale
16. Total Acreage
17. Site Location Map
18. Proposed or Requested Zoning
19. Surveyor's Certificate
20. Ownership Certificate
21. Notary Certificate
22. Show existing structures and dimension structures to property boundaries
23. Show building setbacks as per the proposed zoning of the subject property

**ALL THE FOLLOWING MUST BE SUBMITTED FOR A REZONING TO BE CONSIDERED.**

The completed petition must be presented to the Planning Commission Recording Secretary at least ten (10) business days prior to the Planning Commission meeting which it is to be considered. 12:00pm EST is the deadline.

Six (6) black and white or blue line copies of the plat. The sheet size for the plat shall be a minimum of eighteen inches (18") by twenty-four inches (24") and not larger than twenty-four inches (24") by thirty-six inches (36").

The complete legal description, and adjacent property owners names and mailing addresses must be submitted on a computer disk (also printed out on a separate sheet of paper).

There is a \$100.00 filing fee, which must be paid when the petition is submitted.

There is a \$5.00 plus current postal rate, per adjacent property owner, fee for certified letters which must be paid when the petition is submitted.

There is a \$15.00 fee Rezoning sign. The receipt, showing the purchase of the signs must be turned in when the petition is submitted.

\* The Planning Commission meets on the second and fourth Tuesday of each month.

DRAFT

**Petition For Rezone**

**(Please Print or Type Information Clearly)**

Date: \_\_\_\_\_

Names of Property Owners of Land to be Rezoned:

- 1.) \_\_\_\_\_
- 2.) \_\_\_\_\_

Address of Property Owners of Land to be Rezoned:

- 1.) \_\_\_\_\_
- 2.) \_\_\_\_\_

Telephone Numbers of all Property Owners:

- 1.) ( \_\_\_\_\_ ) \_\_\_\_\_
- 2.) ( \_\_\_\_\_ ) \_\_\_\_\_

Email Address of all Property Owners:

\_\_\_\_\_

Specific Location and Addresses of Property to be Rezoned:

\_\_\_\_\_  
\_\_\_\_\_  
\_\_\_\_\_  
\_\_\_\_\_

Size (Acres) of Property to be Rezoned:

\_\_\_\_\_

Current Zoning Classification of Property to be Rezoned:

\_\_\_\_\_

Requested Zoning of Property to be Rezoned:

\_\_\_\_\_

Present Zoning Classification of Adjacent Property:

\_\_\_\_\_

Proposed Use of Property:

\_\_\_\_\_  
\_\_\_\_\_  
\_\_\_\_\_  
\_\_\_\_\_

DRAFT



Rezone Signs:

Number of signs posted: \_\_\_\_\_

Location of signs posted: \_\_\_\_\_

Signature verifying the above sign(s) have been placed in the above location prior to the application being submitted:

Signature(s) of Owner(s) of Property to be Rezoned:

1.) \_\_\_\_\_ 2.) \_\_\_\_\_

3.) \_\_\_\_\_ 4.) \_\_\_\_\_

(Do Not Write Below This Line)

Fees:

\$100.00 Filing Fee = \$ \_\_\_\_\_

\$5.00 + Current Postal Rate x \_\_\_\_\_ = \$ \_\_\_\_\_ (Adjacent Property Owners – Certified Letters)

Total Amount Due = \$ \_\_\_\_\_

Cash \_\_\_\_\_ Check \_\_\_\_\_

Collected By: \_\_\_\_\_

DRAFT

**APPENDIX 1F**  
**REQUEST FOR WAIVER**

DRAFT

DRAFT

**Request for Waiver**

Name of Applicant(s): \_\_\_\_\_

Name of Engineering Firm (If Applicable): \_\_\_\_\_

**Owner Information:**

Name: \_\_\_\_\_

Address: \_\_\_\_\_

Phone: \_\_\_\_\_

Email: \_\_\_\_\_

Location of Property: \_\_\_\_\_

**State in Detail Why a Waiver Is Being Requested:**

\_\_\_\_\_  
\_\_\_\_\_  
\_\_\_\_\_  
\_\_\_\_\_  
\_\_\_\_\_

**State Facts Upon Which The Waiver Is Relying Upon:**

\_\_\_\_\_  
\_\_\_\_\_  
\_\_\_\_\_

**List Any Attachments To This Petition:**

\_\_\_\_\_  
\_\_\_\_\_

**Provide A Short Explanation On Why You Believe The Waiver Should Be Approved:**

\_\_\_\_\_  
\_\_\_\_\_  
\_\_\_\_\_

\_\_\_\_\_  
**Signature of Owner**

\_\_\_\_\_  
**Date**

\* Include documentation verifying proof of ownership of the property for which the waiver is being requested.

DRAFT

## 2.0 TRAFFIC SIGNAL DESIGN

### 2.1 SIGNAL DESIGN ELEMENTS

Any traffic signal proposed for installation on City streets shall meet the minimum criteria as outlined in the *Manual on Uniform Traffic Control Devices (MUTCD)* and the *ALDOT Traffic Signal Design Guide & Timing Manual*, latest editions. Additionally, traffic signals proposed for installation on City streets may only be considered at locations where their spacing from existing signals would not deteriorate roadway capacity along the street. A request for traffic signalization shall address the minimum criteria for installation as well as the roadway capacity impacts created by signal spacing. A development shall be responsible for all or part of any right-of-way, design, hardware, and construction costs of a traffic signal if it is determined that the signal is warranted by the traffic generated from the development. The procedures for traffic signal installation shall be in accordance with criteria established by the MUTCD, the City of Phenix City, and the Alabama Department of Transportation (ALDOT), as applicable.

#### 2.1.1 Signal Heads

All signal lenses shall be 12" LED balls in yellow aluminum signal head housing. Black back plates with reflective strips are required on City signals. Back plates are also typically required by ALDOT on all state routes.

Signal head placement shall adhere to the standards set forth in the MUTCD, latest edition. A minimum of two signal faces shall be provided for the major movement on each approach, even if the major movement is a turning movement. If the signal faces provided on the mast arm or span wire are more than 180 feet beyond the stop line, a supplemental near side signal face shall be installed as required by the MUTCD. Where dual left turn lanes are provided, a separate left turn face shall be provided for each lane.

In general signal heads should be centered over the lanes to which they apply, while adhering to lateral positioning guidelines within the MUTCD. Adjacent signal faces on the same mast arm or span wire shall be placed no closer than 8 feet apart. The placement of the signal head over the roadway shall be such as to provide a minimum 17-foot vertical clearance from the bottom of the signal head to the roadway.

#### 2.1.2 Signal Supports

All signals shall be decorative mast arms unless approved by the City. All mast arm signal poles shall be smooth, round poles with upswept type arms and powder coated gloss black (P-33) finish. Poles are to be assembled with the ornamental pole per the City standards.

Strain poles and mast arm poles should be located as far as practical off the edge of

roadway while staying within the right-of-way. Additionally, the poles shall be located to maximize the separation between the foundation and existing utilities. The location of strain poles and mast arm poles shall comply with the AASHTO *Roadside Design Guide* and ALDOT standards and approved by the City.

### 2.1.3 Cabinet and Controller Equipment

The standard controller to be used at all signalized intersections shall be a Siemens M60 or approved equal 16-phase, NEMA-compatible controller that meets current ALDOT standards and specifications. All cabinet components shall be capable of operating with flashing yellow arrow (FYA) sequencing. Controller cabinets shall be ground mounted cabinets, unless otherwise approved by the City Engineer. The controller cabinet shall be oriented so that the traffic personnel will be facing the intersection while looking in the cabinet. Controller cabinets should be located as far as practical off the edge of the roadway and in the same intersection quadrant as the power source.

### 2.1.4 Communications

Signal interconnect provides communication between two or more individual traffic signals to provide coordination of signals. The different types of communication include hardwire, twisted pair, closed loop and radio. If communications between a new signalized intersection and an existing signalized intersection is proposed, the existing signalized intersection's communication equipment shall be upgraded as part of the new signalized intersection construction.

#### 2.1.4.1 Extension of Existing System

If a new signal is to be added to an existing hardwire connection, a local controller with adequate cabinet space for an interconnect panel must be designated as the system supervisor. If the signal modifications are significant, the replacement of the hardwire systems with a more advanced interconnect system may be necessary.

To connect a new signal with an existing twisted pair connection, a local controller must be designated as the system supervisor and communications boards must be installed in each controller.

If a new signal is to be added to an existing closed-loop system or if an existing communication system is being upgraded to a closed loop system, all controllers must be of the same make or all controllers must be upgraded.

#### 2.1.4.2 New System Implementation

Closed loop systems, radio interconnect, cellular, and fiber systems are most common for new installations. Radio signals require a clear line of sight between antennas and transmissions may be disrupted by rolling terrain, dense tree



canopies and/or tall building structures. A closed loop twisted pair interconnect system may be installed underground.

### **2.1.5 Signal Wiring, Conduit, and Junction Boxes**

All signal head wiring is required to be eight (8) conductor stranded, regardless of signal head (3-, 4- or 5- section heads).

A minimum of two (2) – 2” conduits are required for signal cables in each pole foundation as well as any conduits installed under the roadway. Two (2) – 2” conduits are also required for signal cable and loop returns once the run has crossed the roadway. All above ground conduit is required to be rigid metallic, while PVC conduit is the standard for trenched underground use and continuous run of HDPE conduit is the standard for underground bored conduit.

Traffic rated junction boxes are required for all installations throughout the City, regardless of location within the right-of-way. Junction box lids shall have “Traffic” molded into the lid.

### **2.1.6 Power Supply**

The electrical power source for the controller cabinet shall be underground. It shall be designated on signal plans in the same quadrant as the signal controller. The power source should be verified in the field with a representative of the power company before the power source is located on the plans. Any cost imposed by the utility company shall be paid by the contractor or developer until project acceptance by the City.

An uninterruptible power supply (UPS) (battery back-up system Clary SP 1000SN+) is required for all intersections. The UPS shall use the OP72C battery and be housed in a 336S cabinet. The entire UPS system and batteries may be housed in the traffic signal controller cabinet where space allows. A decorative black pole may be required for overhead power supply in areas where the supply is in close proximity to the intersection.

### **2.1.7 Vehicle Detection**

The type of vehicle detector used depends upon the roadway approach volume, the roadway material, and the type of information needed by the controller to operate efficiently at its location with respect to the roadway. Detection shall be approved by the City and could include inductive loops, video, radar, and/or wireless sensors.

#### **2.1.7.1 Inductive Loops**

Inductive loops are installed in roads to detect the presence of passing vehicles and prompt traffic signals to allow sufficient time for queued vehicles to pass

through the intersection. These loops can be installed at the stop line or in advance of the stop line.

**2.1.7.1.1 Stop Line Detection**

Stop line detection, as the name implies, are inductive loops located at or near the stop line on an intersection approach to detect the presence of stopped vehicles and operate in the presence (non-locking memory) mode of detection. Stop line detection is typically used on low speed (25 mph or less) and side street approaches. They are typically used in through lanes on minor approaches (at a minimum), in left turn lanes on both major and minor approaches and across bicycle lanes. When used with a delay, stop line detectors can screen out right turns made on red, or left turns clipping opposing lanes, thus preventing false calls.

If used, the standard size loop is 6' x 50' regardless of lane widths. At large radius intersections, wider loops may be used. The width of the loop in a curbside lane can increase significantly when it is located 10 ft back from a cross street and the intersection has large curb radii.

**2.1.7.1.2 Advanced Detection**

Advanced detection are inductive loops or other forms that can be used with volume density controllers and are located some distance in advance of the approach stop line. If used, the advanced loop is 6' x 6' and located in the through lanes of the major street where speeds are 30 mph or greater. These loops operate in a passage or pulse mode and detect vehicles as they pass a specific point. Advanced loop detection can provide the controller with information on vehicles approaching the intersection, and in the case of a volume density controller, can count the number of vehicles on the approach that are waiting with a red signal indication. The location of these loops is based on the safe stopping distance of approaching vehicles which varies according to the approach speed.

**TABLE 2.1 Advanced Detector Location**

Approach Speed	Loop Setback
30 mph	140'
35 mph	185'
40 mph	230'
45 mph	285'
50 mph	340'
55 mph	405'

*Source: ITE Manual of Traffic Signal Design*

### 2.1.7.2 Video/Radar Detection

Video and radar detection can operate in both presence and passage mode, similar to stop line and advanced detection. Detection zones are designated in the image processor to detect the presence of a vehicle and send a call to the controller. Video and Radar detection is often used in place of stop line detection but can also be used for advanced detection. If the intersection units cannot detect advancing vehicles because of the topography and additional downstream units are not feasible, advanced loops may be necessary.

Units are to be mounted on a mast arm on the far side of the intersection for video detection. Proper mounting height is necessary, and varies by location, to ensure the units have an acceptable field of vision. ALDOT has recommended mounting heights and locations within their Standard Drawings. Engineering judgment is required to determine the ultimate mounting location.

### 2.1.8 Railroad Pre-Emption

The MUTCD states that railroad pre-emption shall be provided whenever the distance between a rail crossing and traffic signal is 200 feet or less. Additional warrants include:

- Analysis that indicates vehicle queues from a traffic signal have the potential to extend into or past the rail crossing, and
- Analysis that indicates vehicle queues caused by a passing train have the potential to extend into the signalized intersection and obstruct traffic flow.

The maximum (95%) queue is recommended to be used when determining whether the queue will extend into the track area (within 8 feet of the nearest rail). Refer to ALDOT's *Traffic Signal Design Guide & Timing Manual* for the standard pre-emption sequence and guidelines for computing the minimum interval times.

### 2.1.9 Emergency Pre-Emption

Emergency pre-emption is done by adjusting traffic signals. This starts with communications between a receiving device on a traffic signal and an emitter on an approaching emergency vehicle. The goal is to ensure the emergency vehicle's safe passage through the intersection. Emergency vehicles with an emitter can request traffic signal preemption as they near an intersection. With a goal of reducing response times, emergency pre-emption capability is considered by first responders and transportation agencies an essential function of traffic signal operations.

The MUTCD specifies the standards for going into and out of preemption. The preemption phase will be determined during the design of the traffic signal and the phasing that is being utilized for the individual signal. The City requires that a confirmation light will be provided so that the approaching emergency vehicle will be able to see that the signal has been preempted. The signal designer shall coordinate

with the City to determine the type of emergency preemption to be utilized.

### 2.1.10 Intersection Signage

This section presents only the most commonly required signing associated with traffic signals. Guidance for additional signing may be found in the MUTCD, latest edition.

Span wire/Mast arm mounted sign arrangements shall be installed in conformance with the MUTCD, latest edition. Where overhead signs are installed, they shall have a minimum of 17-foot vertical clearance over the roadway. Examples of these signs include: (1) Left Turn Signal Signs R10-10, R10-12, R10-12M, (2) Lane Control Signs R3-5 through R3-6a, (3) Turn Prohibition Signs R3-1, R3-2, R3-4, R10-5, R10-11a, and (4) Street Name Signs D3-1.

Ground mounted signs to be used at or in advance of signalized intersections shall be installed in conformance with the MUTCD, latest edition. Examples of these signs include Turn Lane Supplemental Sign R3-7, Signal Ahead Sign W3-3, and Street Name Signs D3-2.

Traffic control signs used at signalized intersections in the City shall be high intensity prismatic and of the size specified in the MUTCD. The unit measurement for these signs as shown in signal plans shall be in square feet of sign face.

### 2.1.11 Pedestrian Signal

Pedestrian signals shall be LED countdown signal heads with a “walking person” indication and a “flashing/steady upraised hand”. Audible devices shall also be installed to provide standard information about the status of the signal cycle to pedestrians with disabilities. Pedestrian signal housing shall have a gloss black finish.

Pedestrian push buttons are to be provided on the appropriate corners with a push button for each crossing direction. Each push button shall be placed in accordance with PROWAG guidelines and shall be supplemented by sign R10-3a, which includes the street name of the street to be crossed with an arrow pointing in the direction of the crossing.

The pedestrian signal phase is a special sequence actuated by pedestrian push buttons to allow pedestrians to safely cross a street.

#### 2.1.11.1 Warrants

A pedestrian signal phase with pedestrian signal heads shall be installed when any of the following occur: (1) When Signal Warrant 4, “Pedestrian Volume” in the MUTCD is fulfilled, (2) When Signal Warrant 5, “School Crossing” in the MUTCD is fulfilled, (3) Where there is an established school crossing at the

proposed signal location, (4) Where pedestrians are present and multiphase signal operations (lead-lag left turns, split phasing, etc.) are used that could confuse the pedestrians, (5) Where sidewalk approaches the intersection on opposite sides of the intersection and on the same side of the street, and (6) as required by the City.

### 2.1.11.2 Sequence

The most commonly used sequence is to move pedestrians concurrent with parallel vehicular traffic. Care must be taken however not to move pedestrians during the display of a conflicting left turn or right turn arrow for the parallel vehicular traffic. The exclusive movement sequence moves pedestrians on a phase totally separate from any vehicular phase. When used, pedestrians cross all approaches simultaneously. This sequence should only be used where both pedestrian volumes and conflicting vehicular turning movement volumes are high.

### 2.1.11.3 Timing

Walk timing provides the time necessary for a pedestrian to leave the curb to cross the street. A minimum of 7 seconds shall be given for the walk time. Where large groups of pedestrians cross, field observations should be used to see how long it takes the group to leave the curb. The pedestrian clearance provides the time necessary for a pedestrian to cross the street from the curb line to the center of the farthest travel lane or to a median of sufficient width for pedestrians to wait. A walking speed of 3.5 feet per second is assumed. It is calculated using the equation:

$$PC = W / V_p$$

Where:

- PC = Pedestrian Clearance (sec)
- W = Width of street (curb to center of farthest lane or median) (ft)
- V<sub>p</sub> = Pedestrian walking speed (3.5 ft/sec)

A portion of the pedestrian clearance interval can be timed simultaneously with the yellow and all red intervals of the concurrent vehicular phase.

### 2.1.12 Intersection Lighting

A 12' luminaire arm with a LED cobra head fixture shall be installed on all traffic signal poles at the intersections. Luminaire assembly shall be painted with a gloss black finish and include an equivalent illumination to a 250-watt high pressure sodium fixture.

## 2.2 SIGNAL TIMING

Traffic signal timings shall be developed in accordance with the criteria established by the

MUTCD, the Federal Highway Administration (FHWA) *Traffic Signal Timing Manual*, and the ALDOT *Traffic Signal Design Guide & Timing Manual*, latest editions. The Engineer shall consult with the City Engineer to determine whether a traffic signal will operate as actuated or fixed timing. Fixed time signals are often used in the downtown area and on low volume roads. Actuated signals with a fixed cycle length are more commonly used.

**2.2.1 Phasing**

The phasing of the traffic signals shall correspond to NEMA Standards. If permitted/protected left turn phasing is to be used, the flashing yellow arrow shall be utilized.

**2.2.2 Cycle Lengths**

Signal cycle length is the total time required to complete one (1) sequence of signal phases and generally should be as short as possible. Table 2.2 contains guidelines regarding typical cycle length ranges. Cycle lengths should be calculated for the AM peak hour and the PM peak hour as a minimum. Signal timing software should be utilized to determine optimum cycle lengths.

**TABLE 2.2 Typical Cycle Length Ranges**

Traffic Volumes	Typical Cycle Length Range
Low	50 – 90 sec.
Moderate/High	90 – 130 sec.
Congested	130 – 180 sec.

*Source: ALDOT Traffic Signal Design Guide and Timing Manual, June 2015*

**2.2.3 Actuated Timing Parameters**

The following timing parameters are for stop line detection of an actuated signal: minimum green, vehicle extension (passage time), maximum green (I and II), yellow, all red, walk and pedestrian clearance. The following timing parameters are for advanced detection of a volume density signal controller: minimum initial (minimum green), added initial, initial gap (passage time), time before reduction, time to reduce, minimum gap, maximum green (I and II), yellow, all red, walk, and pedestrian clearance.

**2.2.4 Signal Timing Plans**

A signal timing plan is the combination of cycle length, phasing, splits (green + clearance for each phase) and offsets (for coordinated systems) and should be included with traffic signal plans.

**2.3 PLANS PRODUCTION**

At a minimum, all plan sheets shall have a title block containing the intersection or corridor

name, a scale, the design date, and the design firm information including the initials of the designer. The title sheet shall be stamped, signed, and dated by the Alabama licensed Professional Engineer that supervised the design and plans production.

### 2.3.1 Traffic Signal Notes

This sheet contains, as the name implies, notes of general nature that apply to all the signalized intersections in the plans. It generally includes items from the Alabama Department of Transportation Standard Specifications for Highway Construction (latest edition) for which emphasis is intended for the contractor.

### 2.3.2 Signal Plan

Signal plan sheets shall illustrate the basic intersection geometry, channelization, driveways, ditches, right-of-way, the location of underground and aerial utilities, utility poles, pavement markings, construction stationing (if available), and the power source for the controller cabinet.

The following information concerning the timing, phasing and installation of the signal is also required on the Signal Plan sheet.

#### 2.3.2.1 Installation Notes

This set of notes applies to the signal installation at a particular intersection only. It should not repeat notes covered in the Traffic Signal Notes section. Items typically covered in these notes include but are not limited to:

- Signal Controller/Cabinet – Specifies installation and type
- Electrical Service – Specifies installation
- Junction Boxes – Specifies installation and type
- Signal detectors – Specifies installation
- References – Refers to the Traffic Signal Notes and the signal timing and operations sheets for additional information
- Speed Limits – Posted speed limits on all intersection approaches
- Flashing Operations – Yellow to major street, red to minor street.

#### 2.3.2.2 Signal Head Displays

This diagram shows the signal indication arrangement for each head on the signal plan. It also specifies the signal indication lens size (12"), signal head housing color (yellow), black backplates, and reflective strips

#### 2.3.2.3 Signage Displays

This diagram shows the sign type, MUTCD designation and size for each sign called for on the signal plans. If a non-standard sign, such as a street name sign, is called for, its size, color and legend must be specified.

### 2.3.2.4 Pre-Emption Phasing Diagram

If emergency or railroad pre-emption is included in the signal design, a pre-emption phasing diagram is needed to show all the phasing sequences possible when the signal is pre-empted. The phase in which normal operations is to resume after pre-emption is to be designated. Normally pre-emption is limited to major roadways and not side streets. Exceptions would be if there was a fire/EMS station or hospital located on the side street.

### 2.3.2.5 Signal Sequence/Timing Chart

This table contains all the timing parameters applicable for the type of signal specified in the plans. The timing is shown for each signal phase in addition to its recall status.

### 2.3.2.6 Conflict Monitor Chart

The conflict monitor chart contains the permissible or safe phase combinations to be hardwired into the conflict monitor. Any combination not wired into the circuit board will trip the conflict monitor and place the signal into flash mode.

### 2.3.2.7 Wiring Diagram and Table

The wiring diagram shows the wiring required to accommodate the signal heads, detectors, signal controllers and power source for the signal installation shown on the signal plan. For clarity purposes, the combination of conductors required in each different section of the wiring diagram may be designated with a letter code corresponding to a wiring combination shown in the wiring table.

The wiring table is a chart that describes the various conductor combinations as designated by the letter code on the wiring diagram. The wiring code should include all runs both aerial and underground. It also specifies the conduit size needed for each particular combination of conductors run underground.

### 2.3.2.8 Materials List

This chart shall list the components of the signal equipment that are covered under the 730 "Furnishing and Installing Traffic Control Unit" pay item in the current edition of the ALDOT Standard Specifications. Computed quantities are not necessary as they are part of a lump sum pay item. The following items, as applicable, shall be listed in a box on the plan sheet:

- 3/8" messenger cable
- 1/4" tether wire
- #14 signal cable
- Power source (specify 120V or 240V)
- Miscellaneous hardware



- Mounted signs with hardware (ex. R10-12, R10-10, R10-12M, etc.)
- Backplates with hardware
- Weatherheads
- Pedestrian signal displays
- Pedestrian pushbutton assemblies.

### **2.3.3 Details and Standard Drawings**

The traffic signal plans shall also include all standard details, drawings, and specifications as applicable to the signal design. This includes but is not limited to the City's standard decorative signal pole assembly (see Appendix 2A) and the applicable ALDOT Traffic Signal Operating Plan.

### **2.3.4 Communication Plan**

A communication or interconnect plan shall be required if a traffic signal is being coordinated with other signal installations, via hardwire, radio, fiber optic, or other means. The plan shall illustrate required equipment such as master controllers, and the placement of communication cables, either underground or aerial, and tabulate all related interconnect quantities. The communication plan sheet shall indicate all signal and/or utility poles to which communication cables will be attached. In the case of radio coordination, the plan shall illustrate all necessary antennae, master controllers or other required equipment.

### **2.3.5 Construction**

Refer to Section 8.0 for requirements during construction.

### **References**

*Manual on Uniform Traffic Control Devices*, U.S. Department of Transportation, Federal Highway Administration (2009)

*Traffic Signal Design Guide & Timing Manual*, Alabama Department of Transportation (June 2015)

*NCHRP Report 812, Signal Timing Manual, 2<sup>nd</sup> Edition*, Transportation Research Board (Completed 2014)

*Roadside Design Guide, 4<sup>th</sup> Edition*, American Association of State Highway and Transportation Officials (2011)

*ALDOT Standard Specifications for Highway Construction* (2018)

*Public Right-of-Way Accessibility Guidelines (PROWAG)*, United States Access Board (2011)

DRAFT

**APPENDIX 2A**  
**DECORATIVE SIGNAL POLE ASSEMBLY**

DRAFT

DRAFT



DRAFT

## 3.0 TRAFFIC IMPACT STUDIES

### 3.1 TRAFFIC IMPACT STUDY REQUIREMENTS

The City has established Traffic Impact Study (TIS) requirements for the purpose of ensuring that both the quantitative and qualitative aspects of traffic circulation impact on the citizens, neighborhoods and businesses of the City are considered and properly mitigated. Application of these standards is intended to appropriately regulate and balance the increased traffic flow generated by development with the need to reasonably preserve the quality of life and the environment within our community.

#### 3.1.1 General

The TIS shall identify the traffic impacts and potential problems to be generated by a proposed use, and improvements required to ensure safe ingress and egress from a proposed development, maintain street capacity, and eliminate hazardous conditions. The following policies and guidelines have been established for the preparation of a TIS for development proposals of all land use types. These policies exist to ensure consistent and proper traffic planning and engineering practices are followed when land use actions (rezoning, site plan approval, PUD approval, subdivision approval, etc.) are being considered. The guidelines provide a standard process, set of assumptions, set of analytic techniques, and a presentation format to be used in the preparation of the TIS.

#### 3.1.2 Applicability

Developers and/or property owners shall be required to conduct a TIS, as described herein, for all proposed development that meet any of the following:

- When traffic generated by the proposed development would cause the daily or peak hour traffic volumes on adjacent streets that serve as access for the development to exceed capacity; or
- When a development proposes to access a collector or arterial roadway and the proposed development is larger than the thresholds shown in Table 3.1 "Traffic Impact Study Thresholds by Land Use". The threshold shall be determined by the full buildout of the project, not by individual phases of the project. If a developer completes a project that does not meet the threshold established in Table 3.1, and later either builds subsequent phases of that project or builds a separate project on an adjacent or contiguous parcel of land to the previous project, the combined development size shall be used to determine if a TIS is required; or
- When in the opinion of the City, significant operational deficiencies, capacity deficiencies, and/or safety concerns on the surrounding roadways and intersections currently exist or would be created as a result of the development's expected trip generation; or

- When a development build-out is not completed within 10-years of initial TIS analysis, an update to the TIS will be required for any new phases. The updated TIS will need to include updates for full build-out scenarios.

**TABLE 3.1 Traffic Impact Study Thresholds by Land Use**

Land Use*	Size
Single Family Home	50 Units
Apartments	80 Units
Condominium/Townhouse	95 Units
Assisted Living	225 Beds
Shopping Center	2,500 SF
Fast Food Restaurant w/ Drive-Thru	1,000 SF
High Turnover Sit Down Restaurant	4,500 SF
Quality Restaurant	6,500 SF
Gas Station w/ Convenience Store	3 fuel pos.
Bank	2,000 SF
General Office	32,500 SF
Medical/Dentist Office	14,000 SF
Light Industrial/Warehousing	50,000 SF
Manufacturing Plant	70,000 SF
Hotel/Motel	85 rooms
Pharmacy w/ Drive-Thru	5,000 SF
Free Standing Discount Store	10,000 SF

\* As Defined by ITE's Trip Generation Manual

The thresholds for land uses that are not depicted in Table 3.1 shall be based upon the level of development expected to generate approximately fifty (50) peak hour trips or three hundred fifty (350) daily trips, whichever is less.

Developers who are proposing projects are strongly encouraged to contact the City Engineer to discuss traffic impact requirements prior to submitting a rezoning application or subdivision/site plans to determine the TIS requirements for each project.

### 3.1.3 Applicant Responsibility

The responsibility for conducting a TIS and assessing the traffic impacts associated with an application for development approval rests with the Applicant. The assessment of these impacts shall be contained within a TIS report as specified herein. It shall be prepared under the supervision of, and sealed by, a licensed professional engineer in the State of Alabama with experience in traffic engineering and transportation planning/engineering.

For all State Highways within the study area, the Applicant is required to meet the requirements of ALDOT in addition to those of the City.

### 3.1.4 Capacity and Safety Issues

Development of property has a direct impact on transportation, including vehicular,



transit, bicycle, and pedestrian traffic. In order to meet capacity and safety needs as they relate to the traffic generated from a particular land use, specific traffic circulation improvements should be made. The goal of the TIS is to address traffic related issues that result from development and to determine the improvements required to address and mitigate those issues. These issues include ensuring street maximum capacities are not exceeded and traffic and pedestrian safety is maintained. The competing objectives of vehicular movement, pedestrians, bicyclists, and others must be balanced in the development review process. The TIS will provide information and guidance as plans are developed and decisions made for the proposed development plan.

### **3.1.4.1 Vehicular Traffic Improvements**

Examples of traffic capacity and safety improvements to mitigate development impacts include road widening, turn lanes, deceleration lanes, intersection through lanes, traffic signals, stop signs, design speed adjustments, modifications to access points, roundabouts and other traffic calming techniques as approved by the City.

### **3.1.4.2 Pedestrian Traffic Considerations and Improvements**

Examples of street conditions that promote safe, comfortable, and convenient pedestrian environments include narrower roadways that promote shorter walking conditions; short blocks; lower prevailing travel speeds; sidewalks; well-defined crosswalks, median refuge areas, islands at street intersections, bump outs, and leading pedestrian intervals. Walkway tunnels and overhead structures are examples of safety improvements that afford maximum protection for pedestrians.

### **3.1.4.3 Bicycle Traffic Improvements**

The addition of on-street bicycle lanes or off-street bicycle paths may be needed to achieve connectivity between the proposed project and the existing bikeway system.

## **3.2 TRAFFIC IMPACT STUDY PROCEDURES AND CRITERIA**

### **3.2.1 Scoping Meeting / Telephone Conference**

#### **3.2.1.1 Purpose**

A scoping meeting/telephone conference prior to the submittal of a request for rezoning or site/development plan will be required and used to determine the study area, study parameters and documentation requirements for conducting a Traffic Impact Study (TIS) for specific development proposals. The parameters determined in the scoping meeting/telephone conference represent a general agreement between the City and the Applicant's consulting engineer, but they may not be all-

inclusive. The Applicant shall be responsible for preparing meeting minutes and submitting them to the City for concurrence. The City retains the right to require additional information and/or analysis to complete an evaluation of the proposed development project.

### **3.2.1.2 Meeting / Telephone Conference Setup and Content**

The applicant is required to contact the City to arrange for a scoping meeting/telephone conference to discuss the TIS requirements and determine the base assumptions. It is incumbent upon the Applicant to discuss the following:

- Previous TIS prepared for the site, if any;
- Location of the site;
- Proposed access and its relationship to adjacent properties and their existing/proposed access;
- Preliminary estimates of the site's trip generation and trip distribution at buildout;
- Identification of proposed year of build-out;
- Anticipated roadway improvements required to mitigate development impact;
- Phasing plan proposed; and
- Special analysis needs.

### **3.2.1.3 Results of Meeting / Telephone Conference**

The scoping meeting/telephone conference shall conclude with the City and Applicant in mutual agreement as documented in meeting minutes with regard to the level of detail and extent to which the TIS will need to address the following:

- Study area for the impact analysis;
- Other developments within the study area;
- Existing intersection counts;
- Intersections and roadways to be studied in detail;
- Existing traffic volume forecast;
- Location of the nearest bicycle and pedestrian facilities; and
- Special analysis needs (non-traditional peak hours, neighborhood impacts, access management plans, etc.).

## **3.2.2 Evaluation Elements**

The key elements of the project TIS shall be specified by the City from the following list:

- Conformity with the transportation related policies of the City, including any other adopted access plans;
- Peak hour intersection and roadway level of service;
- Appropriateness of access locations;
- Location and requirements for left turn lanes or deceleration lanes at accesses or intersections, including recommendations for taper lengths, storage lengths, deceleration lengths, and other geometric design requirements as required by the City or ALDOT;
- Sight distance evaluations and recommendations (intersection, stopping, passing);
- Continuity and adequacy of pedestrian and bike facilities;
- Recommended traffic control devices for intersections which may include two (2) way stop control, four (4) way stop control or yield signs, school flashers, school crossing guards, crosswalks, traffic signals or roundabouts;
- Traffic signal and stop sign warrants;
- Other items as requested by the City in the scoping meeting/telephone conference; and
- Neighborhood and public comments.

### 3.2.3 Roadway Traffic Volumes / Traffic Counts

Current morning and afternoon commuter peak hour (7-9 A.M. EST and 4-6 P.M. EST) traffic counts as specified by the City shall be obtained for the roadways and intersections within the study area for one (1) non-holiday Tuesday, Wednesday, or Thursday. Each peak hour count shall be conducted over the designated hours (or as specified by the City) and shall include fifteen (15) minute count data to clearly identify the peak hours. The afternoon peak hour counts shall be extended from 2-6 P.M. for areas with adjacent Schools.

Weekend counts and/or daily counts may also be required where appropriate and when required by the City. Pedestrian counts and bike usage should be obtained where practical. Vehicle classification counts may also be required by the City.

In any case, these volumes shall be no more than one (1) year old (from the date of application submittal). Summaries of current traffic counts shall be provided. Based on the impacts to daily and peak hour traffic volumes from the School District or immediately adjacent City or County schools, the City will require the use of adjustment factors for data collected during non-school times. Adjustment factors proposed for use in any TIS shall be approved by the City. If in the opinion of the City, the proposed adjustment factors will not accurately reflect traffic conditions that would be in place during school operations, traffic count data will not be accepted and will require collection during those periods when the educational facilities are in operation.

As part of the TIS, an annual growth rate of adjacent roadways and intersections will be developed. Growth rates utilized in the preparation of a TIS must be based on historical traffic growth, use of a regional travel demand model or other methods as approved by the City. Application of traffic growth shall be applied for buildout conditions and other interim development levels as required and approved by the City.

### **3.2.4 Intersection and Approach Level of Service**

As a minimum, A.M. and P.M. peak hour intersection and approach levels of service shall be determined for the existing signalized and unsignalized intersections at all study intersections and roadways. Additional intersections should be included in the analysis where post development conditions are considered by the City to be significant. If the development is within an existing signal system, the impact to the system shall also be evaluated. The analysis shall use procedures as described in the latest edition of the Highway Capacity Manual. Capacity analyses for intersections shall be based on individual approach lane LOS whereas impacts on roadways shall be based on daily traffic volumes and the specific roadway classification.

### **3.2.5 Trip Generation Rate**

If trip generation rates established in the *ITE Trip Generation Manual*, latest edition, or other industry publications accurately reflect the trip generation characteristics of a particular land use proposed, those trip generation rates may be used in forecasting traffic to be generated by a development.

When data is not available for a proposed land use or if a land use unique to the area is proposed, the Applicant must conduct a local trip generation study following procedures prescribed in the *ITE Trip Generation Handbook* and provide sufficient justification for the proposed generation rate. This rate must be approved by the City prior to its use in the TIS.

### **3.2.6 Preliminary Land Use Assumptions**

The trip generation values contained in studies submitted prior to the establishment of a site development plan shall be based on the maximum number of dwelling units permitted by the Zoning Ordinance for the approved land uses and/or the maximum trip generation rates for the nonresidential development proposed land use action. When a TIS is being developed for a project with an established site development plan, trip generation shall be based on actual dwelling unit counts and square footage(s) proposed on the final plan.

### **3.2.7 Trip Generation Table**

The Applicant shall prepare a Trip Generation Table, listing at a minimum, each type of land use within the site at build-out, the size and unit of measure for each land use, trip generation rates (total daily traffic, A.M. and P.M. peaks), the resultant total trips

generated, the formulas used to generate the trips, and ITE land code (if utilized).

### 3.2.8 Trip Distribution

The distribution of site generated traffic must be documented in the TIS. The procedures and rationale used in determining the trip distributions for proposed developments must be fully explained and documented. It is recommended the Applicant coordinate with the City to establish an acceptable distribution pattern. Distribution patterns assumed for development shall be illustrated in graphic format as part of the TIS report.

### 3.2.9 Intersection Delay

An A.M. and P.M. commuter peak hour intersection LOS analysis shall be conducted for each intersection analyzed in the TIS for existing conditions and those that reflect post development conditions. This analysis shall be based on procedures specified in the latest edition of the *Highway Capacity Manual*. The intent of this analysis is to establish the existing and post development intersection delays and related LOS for comparison and determination of impacts on operations.

### 3.2.10 Driveway Access

Site driveways shall be analyzed to determine the LOS for each access point. If a driveway capacity analysis demonstrates a LOS of "D" or worse, the TIS shall address this issue by determining if a traffic signal is warranted or if an operational change is acceptable (such as a turn restriction), and whether the driveway will interfere with the adjacent street traffic.

Driveway plan concepts for a development shall be submitted to the City for approval prior to development of construction plans. Because frequent curb cuts and driveways providing access to numerous adjoining properties are an impediment to the proper functioning of major streets, on-site circulation and cross-access agreements between lots are encouraged. Minimum spacing of driveways and other curb cuts shall conform to City Standards.

Where an intersection contains a left turn stacking lane, any driveway opposite such lane shall not permit left turns into or from the driveway. Raised islands or other approved methods of restricting these movements will be required as approved by the City. Limitations on movements from driveways near intersections shall also apply to deceleration lanes.

Various roadways in the City have center medians that have been constructed for both traffic safety and aesthetic considerations. Any alteration of existing or planned roadway medians shall only be allowed at the discretion of the City Engineer. Alterations to existing medians shall only be considered where such alteration is deemed by the City to be in the public interest. In those cases where

medians are proposed for alteration as part of a development, it will be incumbent on the Applicant to demonstrate through traffic operation analysis in the TIS that such alteration can be implemented and not compromise public safety.

On those routes maintained by the Alabama Department of Transportation, an access permit is required from that agency. The City shall be copied on all ALDOT permit applications within the City and its planning jurisdiction.

### 3.2.11 Traffic Signals

Any traffic signals proposed for installation on City streets are required to meet the minimum criteria as outlined in the MUTCD, latest edition. A signal warrant analysis for potential signal locations is required and shall consist of a review of the applicable signal warrants contained in the MUTCD. Meeting the minimum warrants does not guarantee that a traffic signal will be permitted by the City. On roadways controlled by ALDOT, procedures for meeting traffic signal warrants as established by the Department shall be followed.

Proposed and existing access points, proposed intersections, and existing intersections affected by the land use that have any potential for traffic signalization will be reviewed and discussed during the scoping meeting/telephone conference. During the scoping meeting/telephone conference, an outline of locations for signal warrant analysis will be determined by the City. Alternatives to signalization at potential signal locations will be discussed in the scoping meeting/telephone conference and the TIS report. The alternatives to adding new intersections would include added access points, limited movements at access points, frontage roads, joint use access points, roundabouts and other such designs as required and/or approved by the City.

If any signal timing and/or phasing changes are proposed as a mitigation measure of a TIS, an appropriate analysis of the intersection where the signal exists shall be conducted to demonstrate the potential implications of the suggested modifications. Such modifications to existing traffic signals shall require submittal of a request for such change with supportive documentation of analysis and findings and shall not be undertaken without approval from the City.

Sight distance concerns that are anticipated or observed which may impact driveway, intersection, or roadway operation and safety need to be discussed in the TIS. Recommendations regarding stopping sight distance, intersection sight distance, and passing sight distance needs should be provided by the Applicant's traffic engineer for detailing on the final development, site plan, or final construction plans. Intersection sight distance requirements for driveways and intersections shall meet the criteria as set forth in Section 4.0 – Roadway and Parking Design.

### 3.2.12 Mitigation Measures

When a project's vehicular impacts do not meet the minimum acceptable level of service standard, the TIS shall include feasible measures which would mitigate the project's impacts. An appropriate measure of traffic mitigation would be the ability of roadway, intersection, and traffic control improvements to maintain acceptable levels of service for the impacted facility. In the case of interstate and arterial routes, a level of service of "D" for post development conditions would be required and a post level of service of "C" would be required on all other roadways and intersections. Mitigation measures could include the addition of added through lanes, left turn lanes, right turn lanes, improved traffic control, access management and other such measures as deemed appropriate by analysis and concurrence by the City.

### 3.2.13 Traffic Signal Operations Improvements

Traffic signal improvements shall include upgrading signals to include additional signal phases and timing plans, signalization of an unsignalized intersection and/or implementation of a coordinated traffic system. Signal improvements and/or installations on City streets must be approved by the City prior to construction. Traffic signals recommended to be installed on ALDOT roadways shall be jointly approved by ALDOT and the City prior to construction.

### 3.2.14 Geometric Improvements, Street Widening, and Other Physical Improvements

Mitigation measures, which include street widening, and other physical improvements must be demonstrated to be physically feasible and must meet minimum City standards for both on-site and off-site improvements. The basic TIS analysis shall include a determination of the need for left and right turn lanes as a result of development generated traffic. The analysis techniques utilized shall include procedures and methods outlined in the National Cooperative Highway Research Program (NCHRP) Report 2013 or other methodologies as approved by the City.

The need for turn lanes and other auxiliary lanes shall be determined for each development access and analyzed intersection included in the TIS. The basis of design for such improvements shall be as outlined in this Manual in Section 4.0 – Roadway and Parking Design or other nationally accepted standards (i.e., AASHTO, ALDOT, etc.) as approved by the City. All proposed project entrances onto arterial and collector streets shall be evaluated as to whether they require deceleration lanes as outlined in this Manual in Section 4.0 – Roadway and Parking Design. The developer is responsible for obtaining any additional ROW needed for improvements.



### 3.3 TRAFFIC IMPACT STUDY REPORT CONCLUSIONS

The findings of the TIS shall be provided in summary format, including the identification of any areas of significant impacts and recommended improvements/mitigation measures to achieve the maximum volume standards for all modes.

#### 3.3.1 Geometric Improvements

The TIS shall include recommendations for all geometric improvements such as pavement markings, signs, adding through or turn lanes, adding project access and assorted turn lanes and changes in medians. Sufficient dimensions/data shall be identified to facilitate review.

#### 3.3.2 Responsibility

The TIS shall describe the location, nature and extent of all transportation improvements required to achieve the required post development levels of service within the study area. The Applicant shall be responsible for implementation of the post development mitigation measures.

### 3.4 TRAFFIC IMPACT STUDY REPORT OUTLINE

#### 3.4.1 Introduction

Describe the purpose of the report and study objectives.

#### 3.4.2 Proposed Development

The following components should be included:

- Site Description – Include small version of site plan as a graphical figure.
- Site Location – Include site location map.
- Zoning – State current and proposed zoning of the property.
- Time Frame of Development – Include any phasing of development that is planned.

#### 3.4.3 Existing Traffic Conditions

The following components should be included:

- Traffic Count Data – Introduce and illustrate current traffic counts for the study area roadways and intersections.
- Existing Conditions Capacity Analysis – Evaluate study area roadways and/or intersections based upon methods in the latest edition of the Highway Capacity Manual.
- Summary of Existing Traffic Conditions in the study area



### 3.4.4 Future Traffic Conditions

The following components should be included:

- Background Traffic Growth – Discuss background growth rate and apply the background growth rate for the time frame for the development.
- Inclusion of Planned or Programmed Improvements – In the event any of the Planned (Unfunded) or Programmed (Funded) improvements are to be included in the analysis of future traffic conditions, a status of the projects and time frame of the projects should be discussed.
- Trip Generation Estimates – Estimate trip generation potential for each level of development.
- Trip Distribution – Describe the anticipated routes for traffic expected to be generated by the proposed development and illustrate the findings in graphic format.
- Traffic Assignment – Assign traffic expected by the proposed development to the study area roadways based upon the distribution patterns established in the trip distribution.
- Future Conditions Capacity Analysis – Evaluate the study area roadways and intersections as well as site accesses with post-development traffic volumes based upon methods in the latest edition of the Highway Capacity Manual.
- Identify Capacity Deficiencies – Identify roadways and/or intersections in which capacity deficiencies are expected for future traffic conditions.
- Recommended Roadway and Traffic Control Improvements – Develop potential improvements for the study area roadways and intersections aimed at mitigation of traffic impacts resulting from development traffic.
- Capacity Analysis with Recommended Improvements – Demonstrate the effectiveness of Recommended Roadway and Traffic Control Improvements and resultant levels of service.

### 3.4.5 Summary and Conclusions

Provide a summary of the findings of the TIS to include existing traffic conditions, future traffic conditions for each level of development, and the recommended improvements aimed at mitigating potential traffic impacts resulting from the proposed development for each improvement.

## **References**

*Trip Generation Manual, 10<sup>th</sup> Edition*, Institute of Transportation Engineers (2019)

*Trip Generation Handbook, 3<sup>rd</sup> Edition*, Institute of Transportation Engineers (2017)

*Manual on Uniform Traffic Control Devices*, U.S. Department of Transportation, Federal Highway Administration (2009)

*Highway Capacity Manual, 6<sup>th</sup> Edition*, Transportation Research Board (2016)

DRAFT

## 4.0 ROADWAY AND PARKING DESIGN

### 4.1 INTRODUCTION

This section of the Public Works Manual addresses the design requirements for public roadways and rights of way.

### 4.2 ROADWAY DESIGN ELEMENTS

Roadways shall be designed in accordance with this Manual, the American Association of State Highway and Transportation Officials (AASHTO) *A Policy on Geometric Design of Highway and Streets* (Green Book), the AASHTO *Roadside Design Guide*, the Federal Highway Administration (FHWA) *Manual on Uniform Traffic Control Devices* (MUTCD), the International Fire Code (IFC), and all other State and Federal applicable standards. The accepted standards used for design in the City are presented below.

#### 4.2.1 Design Criteria

##### 4.2.1.1 Design Controls and Criteria

New public roadways or improvements to existing roadways within Phenix City shall be designed based on the street or road classification, volume of traffic and design speed. See Table 4.1 for Maximum Volumes by Classification.

**TABLE 4.1 Maximum Roadway Volumes by Classification**

Classification	Two-Lane		Three-Lane		Four-Lane		Four-Lane Divided (5-Lane)		Six-Lane	
	Maximum Volumes									
	Peak Hour (vph)	Daily (vpd)	Peak Hour (vph)	Daily (vpd)	Peak Hour (vph)	Daily (vpd)	Peak Hour (vph)	Daily (vpd)	Peak Hour (vph)	Daily (vpd)
Arterial* (Principal and Minor)	1,300	13,300	1,570	15,700	2,050	20,050	2,540	25,400	3,750	37,500
Major Collector*	1,030	10,300	1,290	12,900	1,620	16,200	1,770	17,700	2,600	26,000
Minor Collector**	500	5,000	630	6,300	790	7,900	860	8,600	N/A	N/A
Local Street*	1,030	10,300	1,290	12,900	1,620	16,200	1,770	17,700	N/A	N/A

\* Developed by Skipper Consulting, Inc. and approved by the Alabama Department of Transportation

\*\* Based on trip generation for 500 detached residential dwelling units from ITE

\*\*\* Based on maximum daily volumes from standards of other communities in Southeast United States

**4.2.1.1.1 Street and Road Classifications**

The street or road classification is determined based on the street hierarchy or function. Based on definitions from the Federal Highway Administration (FHWA), the traditional street and road classifications are as follows:

- Arterial – Arterials carry large volumes of traffic. They connect principal urbanized areas or activity centers, schools, and industrial centers. The Phenix City Express (PEX) operates fixed routes along some of the arterials. Principal arterials include US 80, US 280 and US 431. Minor arterials include Martin Luther King Jr. Parkway, Colin Powell Parkway, Broad Street, and Summerville Road.
- Collector – Collectors connect local roads and streets with arterials while balancing mobility with land access. Examples of collectors include Airport Road, Idle Hour Drive, Lakewood Drive, Pierce Road, Sandfort Road, and Stadium Drive.
- Local – Local roads provide access to residential areas, businesses, farms and other local areas.

A complete listing of the City’s streets along with their classifications can be found in Appendix 4A.

**4.2.1.1.2 Design Vehicles**

The largest design vehicle likely to frequent the roadway (or parking facility) shall be considered during design of critical features, such as radii at intersections and radii of turning roadways. Where a roadway is identified as a fire access road/lane, radii shall be designed to handle the largest fire apparatus with minimum difficulty. The school bus or garbage truck shall also be considered for the design of some subdivision street intersections. In some cases, larger radii may be required.

**TABLE 4.2 Roadway Design Vehicles**

Classification	Design Vehicle
Arterial (Principal and Minor)	WB-50
Major Collector	WB-40
Minor Collector	WB-40
Local Street (Commercial)	WB-40
Alley	SU

**4.2.1.2 Design Speed**

The following minimum design speeds shall be used when determining horizontal and vertical alignment on City streets, unless the City Engineer approves an alternate design speed:

**TABLE 4.3 Roadway Minimum Design Speeds**

Classification	Minimum Design Speed
Principal Arterial	50 mph
Minor Arterial	45 mph
Major Collector	35 mph
Minor Collector	25 mph
Local Street/Cul-de-Sac	25 mph
Alley	15 mph

**4.2.1.3 Horizontal Alignment**

The minimum radius of curvature of streets on the center line shall be based on the design speeds shown in Table 4.3 and are as follows:

**TABLE 4.4 Minimum Radius for Roadway Alignment**

Classification	Minimum Radius
Principal Arterial	758 feet*
Minor Arterial	587 feet*
Major Collector	314 feet*
Minor Collector	198 feet
Local Street/Cul-de-Sac	198 feet

\* Use of superelevation shall be required where determined by City Engineer. (Assumed 8% max superelevation.)

If a speed other than shown in Table 4.3 is used to design the horizontal alignment of the roadway, the minimum radius for the design should conform to the appropriate requirements of the AASHTO Green Book.

A clear line of sight is required across the inside of all horizontal curves. The stopping sight distance is measured along the centerline of the inside lane around the curve. The area bounded by the stopping sight distance and the sight line shall be clear of all sight obstructions, including walls, buildings, signs, and

vegetation.

**4.2.1.4 Vertical Alignment**

The design of the vertical alignment involves the selection of suitable grades to provide minimum stopping sight distance and adequate drainage.

**4.2.1.4.1 Vertical Curves / Sight Distance**

All changes in street grades shall be connected by vertical curves of a minimum length equivalent to that distance necessary to maintain a safe stopping sight distance in accordance with the current standards established by the AASHTO Green Book.

**4.2.1.4.2 Vertical Grade**

In general, streets shall be designed to conform to the topographical conditions of the site and to provide adequate surface drainage. The maximum grade for streets shall be as follows:

**TABLE 4.5 Maximum Grade**

Classification	Maximum Grade
Arterial	6%
Collector	8%
Local Street/Cul-de-Sac	10%

The maximum street grade from the center line intersection of two (2) streets shall be five (5%) percent for a minimum distance of 100 feet. Street grades shall be a minimum of one (1%) percent.

Grades steeper than 10% shall require approval by the Fire Code Official.

**4.2.1.4.3 Vertical Clearance**

Street grades shall be set to maintain a minimum vertical clearance of seventeen (17) feet from the pavement surface to the bottom of the lowest girder under roadway bridge structures and twenty-three (23) feet and three (3) inches from the top of rail to the bottom of the lowest girder over railroad structures. Overhead utilities such as street lighting and traffic signals shall be installed to maintain a minimum vertical clearance of seventeen (17) feet from the pavement surface.

**4.2.1.5 Typical Street Section**

Minimum right-of-way widths, measured from property line to property line; and

minimum street widths, measured from back-of-curb to back-of-curb, where applicable; and sidewalks, shall be as follows:

**TABLE 4.6 Street and Sidewalk Configurations**

Street Classification	Sidewalk Location	On-Street Parking	Min Back of Curb to Back of Curb Width	Min Pavement Width *	Min ROW Width **
Principal Arterial	Both sides	None	53'	48'	80'
Minor Arterial	Both sides	None	53'	48'	80'
Major Collector	Both sides	None	41'	36'	80'
Minor Collector	One side***	7' on One side	35'	30'	60'
Local Street	One side***	7' on One side	31'	27'	60'
Local Street (Low Density)	One side***	7' on One side	28'	24'	60'
Cul-de-sac	One side***	7' on One side	53' Radius	48' Radius	60' Radius

\* All street widths and turn around provisions shall conform to current Fire Code requirements as adopted by the City of Phenix City.

\*\* Additional ROW may be required as determined by the City Engineer.

\*\*\* Where sidewalks are required by the Planning Commission, sidewalks shall be located on the east and north side of the streets unless an alternate location is approved by the City Engineer to avoid conflicts or provide continuity with adjacent sidewalks.

**4.2.1.5.1 Streets**

All roadway pavements shall be constructed to meet the specifications of the City and shall be approved by the City Engineer. Roadways shall be surfaced for their entire width with curb and gutter at each edge, except as provided in this Manual; and shall be provided with all necessary catch basins and storm sewer collection system. Surface layer placement rates and thicknesses must be in accordance with the ALDOT Guidelines for Operation, latest edition, and Section 4.4 of this Manual.

Design and construction of improvements on roadways controlled by ALDOT shall be in accordance with applicable ALDOT requirements and properly permitted prior to construction.

All streets within a subdivision shall be provided with a paved roadway by the developer.

Improvements for streets included in the Downtown Redevelopment Plan (DRP) shall follow the requirements of the DRP.

Street layouts shall be provided for the continuation and connection of streets between adjacent properties whenever such continuation and connection is necessary for the convenient movement and circulation of traffic, effective police and fire protection, access by public service vehicles, and efficient provision of utilities and consistent with the Comprehensive Community Master Plan. The developer or his/her representative is encouraged to coordinate roadway layouts with the Fire Code Official prior to application to the Phenix City Planning Commission to ensure compliance with the IFC.

Existing streets that abut a subdivision shall be continued and the continuation shall be constructed to the required standards or at least as wide as the existing streets, whichever is greater or unless a reduction in width is approved by the Planning Commission, and in alignment with the existing street. Street layouts in subdivisions shall provide right-of-way stub-outs paved to the property line for the future continuation into unsubdivided lands adjoining a sufficient number of streets to meet the purpose previously outlined.

If the adjacent property is undeveloped, the right-of-way of a street to be continued shall be extended to the property line. A temporary turnaround, or a T shaped turnaround, shall be provided with dedicated right-of-way, and with a notation on the subdivision plat that land outside the normal right-of-way shall revert to the abutting properties whenever the street is continued and connected to the adjacent property. The temporary turnaround shall be paved prior to the release of the Maintenance Bond. The Planning Commission may limit the length of such temporary dead-end streets in accordance with the design standards of these regulations. The intention is that the paving and utilities be extended far enough to serve the lots in the subdivision so that the streets and utilities can be extended into the adjacent property as needed.

### **4.2.1.5.2 Sidewalks**

This Manual shall govern the requirements for construction, improvement, and repair of sidewalks. Construction of compliant sidewalks shall be required when a property is either first developed or redeveloped as determined by the Planning Commission. In cases where



only part of the property is redeveloped, the Planning Commission shall require compliance commensurate with the amount of redevelopment.

### 4.2.1.5.2.1 Design Criteria

All sidewalks constructed within the City right-of-way or planning jurisdiction that generally follow the roadway alignment shall comply with the "Public Rights-of-Way Accessibility Guidelines" (PROWAG) issued by the United States Access Board and published in the Federal Register on July 26, 2011 then subsequently supplemented to include guidelines for shared use paths on February 13, 2013.

All other sidewalks constructed within the City right-of-way that do not generally follow the roadway alignment shall meet the requirements of the Americans with Disabilities Act of 1990 and the ADA Standards for Accessible Design, most recent edition.

A minimum four (4) foot continuous clear width shall be provided with five (5) foot by five (5) foot passing areas every two hundred (200) feet or less. Locations of the passing areas shall be shown in the plans submitted to the City Engineer for approval. Street furniture, signs, landscaping and parked cars shall not be allowed to protrude into the pedestrian access route. If the distance between the back of curb and the edge of sidewalk is less than two (2) feet, sidewalk must be a minimum of six (6) feet wide.

The running or longitudinal grade of the sidewalk shall be measured parallel to the direction of the pedestrian travel. Running grades for the sidewalk shall not exceed the general roadway grade where the sidewalk is in the street or highway right-of-way. Any proposed sidewalk construction that exceeds the general grade of the adjacent roadway by more than 3% shall require approval by the City Engineer or, if on state right-of-way, approval by ALDOT.

Running grades for the sidewalk shall not exceed 5% where the sidewalk is not in the street or highway right-of-way. Should the running grades exceed 5%, then the sidewalk must follow the ADA guidelines for a ramp.

The cross slope of the sidewalk shall not exceed 2%. Cross slope shall be measured perpendicular to direction of the pedestrian travel.

Utility manhole or valve covers shall be set outside of the sidewalk as a rule. Where there is insufficient right-of-way to do so, utility manhole or valve covers shall be set flush with the grade of the sidewalk and have skid resistant covers.

Requirements for construction of new sidewalks at corners shall include the requirement to construct accessible curb ramps pursuant to PROWAG or ADA standards as part of the new sidewalk if:

- there are no existing curb ramps at the location;
- the existing curb ramps do not meet current City standards; or
- the existing curb ramps are in poor condition, as determined by the City.

The Alabama Department of Transportation Standard Drawings and Specifications should be consulted for curb ramp construction details.

### **4.2.1.5.2.2 Sidewalk Location**

When required by the Planning Commission, sidewalks are to be located on both sides of arterials and major collectors within the City. Sidewalk on minor collectors, local streets and cul-de-sacs may be located on one or both sides of the roadway. Any sidewalk on a cul-de-sac street may terminate at the beginning of the radius. Roadways classified as alleys do not require sidewalk construction.

Sidewalks shall be located on the side of the street with the storm drainage system and the opposite side from the water line unless an alternate location is approved by the Planning Commission to avoid conflicts or provide continuity with adjacent sidewalks.

Within certain development zones, developments may be required to install a wider sidewalk within the right-of-way as part of the development. The street frontage requirements may also include street trees and decorative lighting. As part of the development review, requirements for street trees may be used to offset front yard buffer requirements.

All developments that have road frontage on an arterial or major collector facility will be required to install sidewalk within the existing right-of-way for the entire arterial or major collector frontage where none exists. If the existing right-of-way is not of sufficient width to construct the sidewalk, additional right-of-way must be provided by the owner or developer at no cost to the City. If a development abuts a minor collector that was designed and approved by the City with sidewalk on the opposite side of the roadway, the development is exempt from this requirement. If a development abuts a minor collector without a continuous sidewalk on either side of the roadway, the location of the sidewalk will be determined by the Planning Commission to avoid conflicts or provide continuity with adjacent sidewalks.

### 4.2.1.5.2.3 Sidewalk Installation

Sidewalks shall be installed in new subdivisions where required prior to the release of bonding.

Sidewalk shall be installed by new residential or commercial construction along any street prior to completion of its construction and/or the issuance of a Certificate of Occupancy (CO). When sidewalk is installed along a development frontage, the sidewalk should terminate with a smooth transition with the adjacent grade. If additional grading is needed along the right-of-way, the plans should reflect the extent of the work.

When a street is designated for reconstruction or a new section is being completed, the Planning Commission shall determine the requirements for installation of sidewalk and/or curb ramps where none exist. Sidewalk and curb ramps shall be repaired or replaced where the existing sidewalk is unsafe, defective or non-compliant, and/or where the sidewalk grades no longer follow the general street grades.

### 4.2.1.5.2.4 Inspections

Prior to acceptance by the City, new sidewalk installed within the right-of-way shall be inspected based on the following guidelines:

Running slope: Shall not exceed the general grade established for the adjacent street or highway

Measuring device: Two (2) foot Smarttool digital level or approved equal

Cross slope: Two (2) percent maximum, checked at ten (10) foot intervals along the centerline of the path of travel.

### 4.2.1.5.2.5 Exceptions

The Planning Commission **may** determine that sidewalk is not required when any one (1) or more of the following conditions apply:

- there is insufficient right-of-way;
- the installation encourages pedestrian traffic in an otherwise dangerous area for pedestrian traffic;
- the installation abuts industrial zoned lands, unless situated between other pedestrian generating areas; or
- there is engineering justification determining that sidewalks are not required based on special circumstances.

### 4.2.1.5.2.6 Requests for Sidewalks

Requests for sidewalk construction independent of new roadway construction or adjacent development/redevelopment may be submitted on the "Request for Sidewalk Construction Form" provided in Appendix 4C.

A request for sidewalk construction may originate with an individual, a neighborhood association or the City Council. Petitions from multiple individuals are encouraged to show neighborhood support but are not required. Requests from citizens should be submitted to the Engineering and Public Works Department. The request should specify the street(s) on which sidewalk construction is requested and state the reason(s) for requesting sidewalk construction. Any existing roadway conditions which support sidewalk installation should be noted, including, but not limited to, the following:

- provide access for walking to schools;
- provide access to pedestrian destinations, such as transit stops, parks, places of worship, places of work and commercial areas;
- provide access for the disabled;
- connect to an existing network of sidewalks;

- show evidence of a worn path; and/or
- history of vehicular/pedestrian crashes.

The Engineering and Public Works Department will evaluate each request to determine if it should be recommended to City Council for budget consideration. If the Engineering and Public Works Department determines that a sidewalk may be warranted, the engineering staff will evaluate the feasibility of construction, considering factors such as:

- available right-of-way or easement for installation;
- terrain;
- existing obstructions, utility poles, landscaping, etc.;
- existing trees and the impact on trees;
- drainage conditions; and/or
- cost estimates.

If the engineering evaluation concludes that construction of the requested sidewalk is feasible, it is added to the list of proposed construction projects and forwarded to the City Council for inclusion in its budget hearing to be considered for funding. Any resident may attend the budget hearing and provide input. If the project is funded, the Engineering and Public Works Department will schedule the design and construction.

### **4.2.1.6 Clear Zone**

The AASHTO *Roadside Design Guide* shall be used to determine clear zone widths for all streets within the City. Most curbs do not have the capability to redirect vehicles, therefore minimum clear zone distances should be provided where practical. The AASHTO *Roadside Design Guide* and the AASHTO Green Book require a minimum offset distance be provided beyond the face of curb, with wider offsets provided where practical.

### **4.2.1.7 Driveways**

A proposed driveway shall not connect to a public street or road, without first receiving approval of the location and cross-section specifications from the City, as applicable. Permit applications and details to Construct a Turnout to Provide Access to a City Street can be found in Appendices 4F and 4G.

When a driveway is proposed to tie to a state route within the limits of Phenix City, the owner or developer must receive preliminary approval from the City

prior to submitting plans to ALDOT. Final approval from the City of Phenix City shall be contingent upon ALDOT approval for developments along ALDOT right-of-way. Any modifications to the driveway location or configuration during the ALDOT permitting process should be reviewed with the City to ensure compliance with these regulations.

When a driveway is proposed to tie to a county route outside of the limits of Phenix City but within the police jurisdiction and/or planning jurisdiction, the owner or developer must receive preliminary approval from the City prior to submitting plans to the Russell County or Lee County Engineering Department. Final approval from the City of Phenix City shall be contingent upon the approval by either Russell County or Lee County for developments along their right-of-way. Any modifications to the driveway location or configuration during the County permitting process should be reviewed with the City to ensure compliance with these regulations.

A proposed driveway shall not connect to a private road unless approved by the City and by the parties with an ownership interest in the private road. A representative of the City shall inspect the driveway(s) as constructed for conformance with the standards of this Manual and any approval granted under it, prior to issuing a certificate of occupancy.

### **4.2.1.7.1 Design Criteria - Residential**

Residential driveway turnouts shall be a minimum of nine (9) feet wide and a maximum of twenty (20) feet wide measured at the right-of-way. In cases where the radius on either side of the driveway causes the twenty (20) foot requirement to be exceeded at the right-of-way, the width will be determined at the tangent of the throat. A drawing will be required to illustrate the width.

All driveway curb cuts shall be constructed in accordance with standards approved by the City Engineer and ALDOT where applicable. Driveway turnouts shall meet the City standard or be designed to meet specific site conditions. If a driveway turnout varies from the standard, appropriate design data should be included with the City Engineer submittal. The minimum radii for the driveway connection to the street is three (3) feet. The City Engineer may require wider driveway radii to avoid lane encroachment by entering or exiting vehicles where narrow street widths exist.

### **4.2.1.7.2 Design Criteria - Commercial**

Two-lane commercial driveway turnouts shall be a minimum of twenty (20) feet wide and a maximum of thirty (30) feet wide measured at the

right-of-way. In cases where the radius on either side of the driveway causes the thirty (30) foot requirement to be exceeded at the right-of-way, the width will be determined at the tangent of the throat. A drawing will be required to illustrate the width.

All driveway curb cuts shall be constructed in accordance with standards approved by the City Engineer and ALDOT where applicable. Driveway turnouts shall meet the City standard or be designed to meet specific site conditions. If a driveway turnout varies from the standard, appropriate design data should be included with the City Engineer submittal. The minimum radii for the driveway connection to the street is fifteen (15) feet for driveways with curb and gutter and twenty-five (25) feet for driveways with a ditch section. The City Engineer may require wider driveway radii to avoid lane encroachment by entering or exiting vehicles where narrow street widths exist.

The thirty (30) foot wide driveway is reserved for commercial and multi-unit residential developments. Driveways with more than two (2) lanes should incorporate channelization features, appropriately marked to accommodate ingress and egress traffic.

Should a commercial driveway require four (4) or more lanes, the ingress lanes and egress lanes shall each be a minimum of twenty (20) feet wide and a maximum of thirty (30) feet wide measured at the right-of-way. The ingress and egress lanes should be separated by a four (4) foot to ten (10) foot wide median.

Driveway width and return radius or flare shall be adequate to serve the volume of traffic and provide for efficient movement of vehicles onto and off of the roadway. However, the width of driveways shall not be so excessive as to pose safety hazards for pedestrians and bicycles. In areas where significant pedestrian and/or bicycle travel is expected, as determined by either the City or ALDOT, the ingress and egress lanes should be separated by a four (4) foot to ten (10) foot wide median with a pedestrian refuge area.

There should be one hundred twenty-five (125) feet of stacking for entering and exiting vehicles at the intersection of an arterial roadway measured from the pavement edge where practical as shown in Figure 4.1. On major and minor collector roadways, the minimum vehicle stack distance shall be seventy-five (75) feet for entering and exiting vehicles measured from the pavement edge where practical.

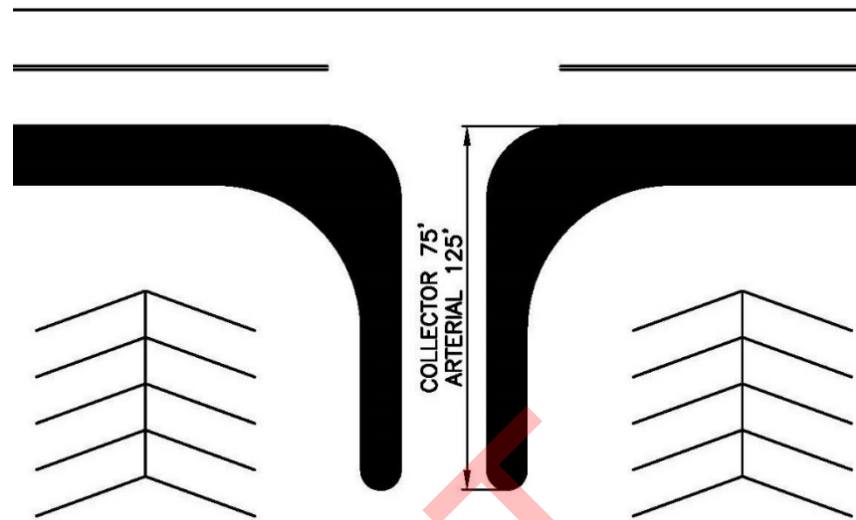
**Figure 4.1 Driveway Stack Length****4.2.1.7.3 Driveway Location**

Corner and double frontage lots in residential developments shall take access from one minor street only unless otherwise approved by the City Engineer. Approved access points shall be clearly noted on the Final Plat.

Driveways shall be located where sanitary laterals/cleanouts and water services/meter boxes are offset five (5) feet from the driveway as shown in the details in Appendices 4D and 4E.

Construction of driveways along acceleration or deceleration lanes, left turn storage lanes, and tapers are prohibited.

Driveways shall not be permitted for parking or loading areas that require backing maneuvers in a public street right-of-way or onto a public or private service drive. Such restrictions will be applicable for roadways classified as collectors and arterials in the City.

Direct access for single family residential lots or parcels shall be prohibited on arterial roadways in the City unless there is no other access option.

Upon approval of a new means of access, a closed driveway shall be graded and landscaped to conform to adjacent land and any curb cut shall be filled in with curb and gutter per the City standards.

When a property is proposed for development or redevelopment,



existing driveways that do not comply with the requirements of this Manual may be utilized under the following provisions:

- The driveway(s) must have been in use for similar purpose within the past three years.
- No significant crashes have occurred that could be attributed to the driveway(s).

Driveways that have not been utilized in the past three years or where the use is significantly more intense based on trip generations shall conform to the current standards.

**4.2.1.7.4 Driveway Spacing**

The minimum spacing between un-signalized driveways along a route shall be as outlined in Table 4.7 and shown in Figure 4.2.

**TABLE 4.7 Driveway Spacing Standards**

Classification*	Posted Speed Limit (mph)					
	55	50	45	40	35	<30
Minimum Driveway Spacing (ft)						
Arterial	500	450	400	350	300	300
Collector (Major and Minor)	350	300	250	200	150	150
Local and Cul-de-sac (Commercial)	--	--	--	--	125' Average**	

Notes: \*Classifications not listed above are not subject to curb cut restrictions.

\*\*Does not apply to Local and Cul-de-sac (Residential). Along Local and Cul-de-sac (Residential) routes, one driveway per parcel shall be allowed unless approved by City Engineer.

Corner and double frontage lots that abut a residential collector and local street will be required to take access only from the local street.

**Figure 4.2 Driveway Spacing Illustration**

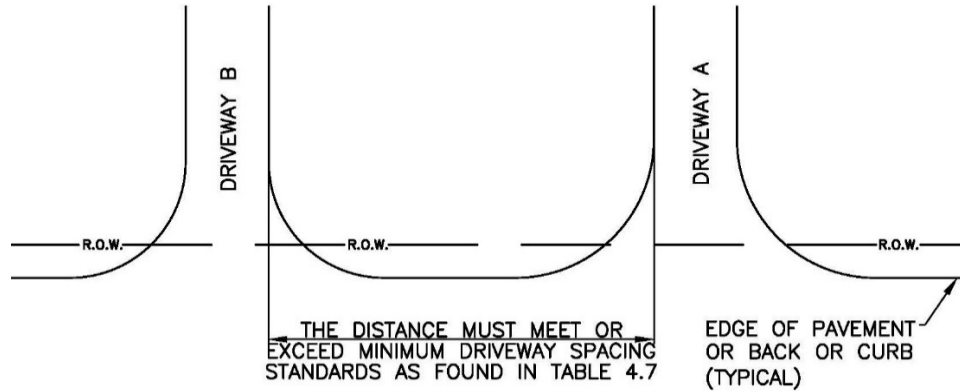

In the case of expansion, alteration, or redesign of an existing development where the Applicant can demonstrate that pre-existing conditions prohibit adherence to the minimum driveway spacing standards, the City shall have the authority to modify the driveway spacing requirements or grant approval of a temporary driveway until such time that minimum spacing requirements can be met or an alternative driveway meeting the requirements of Table 4.7 is approved. Such modifications shall be of the minimum amount necessary.

Driveways allowed along arterial and collector roadways in the City shall be separated from their nearest edge of the curb cut to the corner property lines of an intersecting street a distance equal to the minimum access spacing criteria as outlined in Figure 4.3 and Table 4.8.

**Figure 4.3 Driveway Spacing Along Arterial and Collector Roadways**

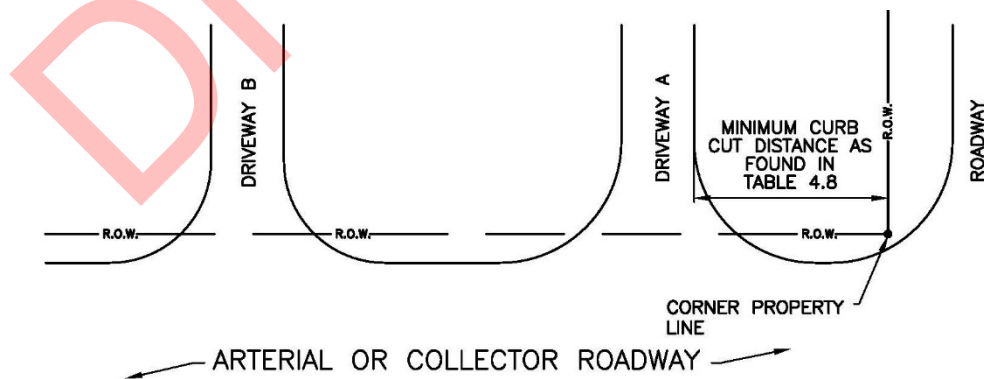

**TABLE 4.8 Curb Cut Distance from Street Corner Property Lines**

Development Type*	Street Type			
	Arterial	Collector	Local (Commercial)	Local (Residential)
Non-Residential	125'	100'	100'	100'
Multiple Unit	125'	100'	100'	100'

Development				
All Other Residential	125'	100'	100'	25'

\* A waiver may be submitted for relief from this requirement for properties currently zoned R-3 or C-3.

Driveway spacing from intersections shall be measured along the right-of-way from the edge of the driveway to the nearest normal edge of pavement of the intersecting street.

No part of a driveway shall be located closer than a distance equal to the flare radius of the driveway from a lot line unless it is a common or shared driveway and/or approval is granted by the City Engineer and/or adjacent property owners as necessary.

**4.2.1.7.5 Driveway Alignment**

Driveways shall be perpendicular to the existing public street or approved private road and are required to align with existing or planned driveways on the opposite side of the road, wherever frontage is not separated by a median. Plans submitted for approval shall show these existing or planned driveways on the opposite side of the road. Offset or skewed driveways create the potential for conflicting left turns or jog maneuvers, resulting in safety or operational problems, and may only be used if a professional engineer demonstrates a perpendicular and/or aligned driveway to be unsafe. Additional information may be required to confirm driveway alignment and/or spacing prior to approval.

**4.2.1.7.6 Shared Driveways**

Common/shared driveways are encouraged to reduce impervious surface and the number of conflict points and should be used where practical. All shared driveways must be constructed in accordance with standards approved by the City Engineer and described herein. In cases where single access driveways are restricted by the spacing requirements outlined in this Manual, a shared driveway may be the only design allowed.

The shared driveway shall be constructed along the common property line between the two (2) properties unless a written easement is provided which allows traffic to travel across one (1) parcel to access another parcel and/or access the public street. Shared driveways, cross access driveways, connected parking lots, and service drives shall be recorded as an access easement and shall constitute a covenant running with the land. Operating and maintenance agreements for these facilities should be recorded with the deed. Shared driveways utilized for single

family residential lots shall not exceed twenty-eight (28) feet in width.

Where a proposed parking lot is adjacent to an existing parking lot of a similar use, there shall be a vehicular connection between the two (2) parking lots where physically feasible, as determined by the City Engineer and/or ALDOT. For developments adjacent to vacant properties, the site shall be designed and constructed to provide for a future connection.

### 4.2.1.8 Private Streets

Private streets are allowed with a waiver granted by the Planning Commission only. Private streets must be constructed to the City's buildup standards for public street and alley construction. The plans for private street construction must be reviewed and approved by the City Engineer. The private street shall commence as part of the overall development, and the construction shall be inspected and certified by an engineering company licensed by the State of Alabama. The construction certification shall be submitted to the City prior to the Certificate of Occupancy being issued. Private streets can be constructed on a separate lot or within a common ingress/egress easement. The lot or easement covering the street shall comply with the City's street width requirements and shall grant the City unrestricted use of the property for emergency access, solid waste collection, and utilities and maintenance of same, if applicable. The City shall not be responsible for repairing, replacing, or maintaining anything related to the private street and its drainage.

Private streets shall have an unobstructed width of not less than twenty (20) feet to meet the International Fire Code as adopted by Phenix City. The minimum width around a fire hydrant on a private access road is twenty-six (26) feet. Private streets must also be sized to accommodate the traffic generated by the development per the traffic study approved by the City.

Appropriate signs shall be permanently maintained at the entrance to the private street system that clearly indicate to the public and to the City police and street maintenance crew that the street system is private property.

Any traffic control devices proposed for the private street systems, such as signs, signals, markings, speed control mechanisms, etc., will be subject to review and approval by the City Engineer. The first seventy-five (75) feet of a private street approach to an existing or proposed signalized intersection shall be dedicated as permanent easement measured from the nearest normal edge of pavement of the public street to provide for traffic signal loop detector placement.

### 4.2.1.9 Greenways

The benefits of combining recreational uses, greenspace conservation goals and

multimodal transportation projects by aggressively pursuing shared use off-road paths for pedestrians and bicyclists has become well recognized. There are economic, social and environmental benefits of greenways and their use is recommended to buffer between competing land uses, soften the urban landscape and provide connectivity between parks and activity centers. Additionally, greenways can protect key watersheds and preserve riparian buffers along the creeks and waterways.

The use of sewer easements for trail systems is common in that it allows for the expanded community use of existing undevelopable land, and often property owners are amenable to amending the existing easements as connection to a trail network can be a valuable amenity to new and existing developments. Second, easements are typically already well maintained, and of sufficient width and topography to allow more economical trail constructions. Lastly, by improving the easements, access to sanitary sewer lines is enhanced for maintenance purposes and the increased presence of joggers, cyclists and walkers increases the overall security of those assets.

### **4.2.1.10 Bicycle and Pedestrian Facilities**

All bicycle and pedestrian facilities constructed within the City shall be constructed in accordance with the *AASHTO Guide for the Development of Bicycle Facilities* and the MUTCD.

When development occurs on a street where a bike route has been designated, the developer may be required to provide a bike path along the property frontage if the City has determined that the bike path is to be constructed on the side of the street that the development is taking place. If no Functional plan is available, the City will determine which side of the street a bike path is to be constructed using all information available.

Maximum detachment of a bike path or sidewalk from the street curb must not exceed 15 ft. This is to avoid pedestrians and bicyclists leaving the alignment of the designated path as a short cut. If head-in parking is permitted adjacent to the bike path/sidewalk or the bike path/sidewalk is attached on arterial streets, two (2) feet of additional of bike path or sidewalk width will be required to allow vehicles to overhang the curb. See Figure 4.4.

### **Figure 4.4 Bike Path or Sidewalk Placement**

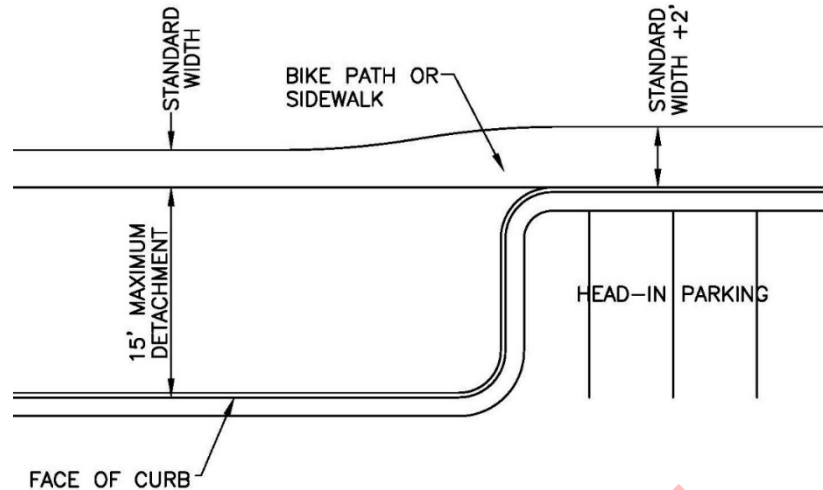

Fixed objects higher than 6 inches should not be closer than two (2) feet to the edge of the bike path/sidewalk. Objects such as signal or utility poles, signs, bus benches, fire hydrants, etc., should not be located in the sidewalk or bike path.

Special lighting treatment may be required for bike paths provided in the middle of developments that are not adjacent to public streets.

Any time a sidewalk or bike path is adjacent to a retaining wall having a vertical drop in excess of twenty-five (25) inches, a pedestrian guardrail or fencing shall be installed along the top of the retaining wall to protect pedestrians and bicyclists from falling off the edge of the sidewalk or bike path.

The following types of facilities for pedestrian and bicycle use shall be considered for construction within the City:

**4.2.1.10.1 Shared Use Paths**

A shared use path is a facility used by pedestrians, bicyclists and other non-motorized users and is detached or separate from the roadway. A shared use path may be within public right-of-way or within an independent right-of-way (i.e. homeowner’s association).

The minimum width of a two-way shared use path is eight (8) feet; however, ten (10) feet is recommended. The minimum width of a one-way shared use path is six (6) feet. A one-way facility requires signing and pavement markings to ensure proper use. A (10) foot minimum vertical clearance is required above the full width of the path.

Additional guidance for design speed, horizontal alignment, vertical grades and sight distance can be obtained from the AASHTO *Guide for the*

### *Development of Bicycle Facilities.*

Unpaved shared use paths are generally referred to as trails. To the extent possible, trails shall provide for pedestrian, bicycle and/or other non-motorized uses. Trails shall be planned, designed and constructed to avoid or minimize degradation of natural resources. Trails shall be soft-surface (crushed aggregate, clay or stabilized earth) except where necessary to prevent erosion and/or resource damage.

Shared use paths may be constructed of pervious concrete and other porous materials provided the runoff through the material will not be directed towards the subgrade of the traveled lane portion of the roadway.

The City may consider the installation of an alternating sidewalk/shared use path system in lieu of sidewalks. Such system must incorporate well-connected sidewalks and paths/trails that link each residential lot with on-site open space, recreational facilities and other amenities within the development site. A sidewalk/shared use plan for the entire development must be submitted to the City Engineer for approval. The plan shall include a map depicting the proposed location of all sidewalks and paths/trails through the development site.

#### **4.2.1.10.2 Bicycle Lanes**

A bicycle lane is a portion of the roadway, designated by signing and/or pavement markings for exclusive use by bicyclists. Bicycle lanes are typically one-way in the same direction as the adjacent vehicular traffic. The MUTCD contains signing and striping requirements for use in designating a bicycle lane.

The AASHTO *Guide for the Development of Bicycle Facilities*, contains guidelines for the minimum width of bike lanes.

To ensure bicyclists' safety, drainage grates must be bicycle-safe and manhole covers shall be at grade. Bicycle lane widths may need to be adjusted to avoid potential safety hazards.

#### **4.2.1.10.3 Shared Roadway**

Roadways without alternate bicycle facilities may be signed as a "Shared Roadway" to alert drivers that the roadway is utilized by both motor vehicle and bicycle traffic. Bicyclists may be accommodated through the use of the through travel lane, a wider travel lane (fourteen (14)+ feet) or paved shoulders. Signs and pavement markings such as "Sharrows" may

be used to alert motorists of the shared use. The AASHTO *Guide for the Development of Bicycle Facilities*, contains guidelines for shared roadways. Most roadways are shared routes even when not signed or marked.

### 4.2.1.11 Cul-de-Sacs

Cul-de-sacs shall be permitted where topographic features or configuration of property boundaries prevent street connections.

A cul-de-sac street shall have a maximum length of seven hundred (700) feet, measured from the center line of the street from which the cul-de-sac takes access to the center of the turnaround at the end of the cul-de-sac. A maximum length of one thousand (1,000) feet shall be allowed where there are no more than twenty (20) lots and the net density does not exceed two (2) lots per acre. All cul-de-sac streets shall be provided at the closed end with a turnaround with a minimum right-of-way radius of sixty (60) feet, and a minimum roadway radius of forty-eight (48) feet.

### 4.2.1.12 Frontage Road/Service Drive

In cases where a frontage road exists, property access should be provided via such frontage road, rather than by direct connection to the abutting arterial or collector street. Rear service drives shall be encouraged, especially for locations where connection to a side street is available. In addition to access along the rear service drive, direct connection(s) to the arterial or collector street may be allowed, provided that the driveways meet the requirements.

In areas where frontage roads or rear service drives are recommended, but adjacent properties have not yet been developed, the site shall be designed to accommodate a future road/facility designed according to the standards of the City and/or ALDOT. The City and/or ALDOT may approve temporary access points where a continuous service drive is not yet available and a Performance Bond or escrow is accepted to assure elimination of temporary access when the service road is constructed.

Frontage road and service drive intersections at the collector or arterial streets shall be designed according to the same minimum standards as described for driveways in Table 4.7 and Table 4.8.

The service drive is intended to be used exclusively for circulation, not as a parking, loading, or unloading aisle. Parking shall be prohibited along two-way frontage roads and service drives. One-way or two-way service drives designed with additional width for parallel parking may be allowed if it can be demonstrated through traffic studies that on-street parking will not significantly



affect the capacity, safety, or operation of the frontage road or service drive. Perpendicular or angle parking along either side of a designated frontage road or service drive is prohibited.

### **4.2.1.13 Median Openings**

The type, location, and length of medians on roadways shall be determined by the City and/or ALDOT, depending on the jurisdiction. This determination will be based on existing and projected traffic conditions; the type, size, and extent of existing and projected development and traffic generated by development; traffic control needs; and other factors.

Median openings intended to serve development must be justified by a traffic impact analysis approved by the City and/or ALDOT. The cost for preparation of the traffic impact analysis and construction of the median opening or openings, including installation and operation of signals and other improvements where warranted, shall be borne by the Applicant.

### **4.2.1.14 Guardrails**

The Alabama Department of Transportation Standard Drawings and Specifications should be consulted for guardrail and guardrail end anchor construction details.

Roadway hazards that may require shielding by a roadside barrier can be placed into five main categories: embankment hazards; fixed objects; non-traversable hazards; end treatments; and ditch sections. Detailed procedures for determining the appropriate clear zone and need for roadside barriers are provided in the *AASHTO Roadside Design Guide*.

#### **4.2.1.14.1 Embankment Criteria**

Height and slope of embankments within the clear zone are the basic factors in determining barrier need for a fill section (for downward slopes). These criteria are based on studies of the relative severity of encroachments on embankments versus impacts with roadside barriers. Obstacles on the slope may require protection and the criteria shown in Sections 4.2.1.14.2 and 4.2.1.14.3 should be used in such cases.

#### **4.2.1.14.2 Fixed Object Criteria**

A clear unobstructed flat roadside is highly desirable. When these conditions cannot be met, criteria to establish barriers needed for shielding roadside objects are necessary. The removal of fixed objects should be considered as the first alternative. If it is not feasible or

possible to remove or relocate a hazard, then a barrier may be necessary. A barrier should be installed only if it is clear that the barrier offers the least hazard potential.

Barrier criteria for fixed objects are a function of the nature of the obstacle and its distance from the edge of the traveled way. The clear zone is defined as the roadside border area, starting at the edge of the traveled way, available for safe use by an errant vehicle. Fixed objects should be removed, relocated, or shielded by a barrier if they are within the indicated minimum clear zone width.

The detailed procedures determining the appropriate clear zone are provided in the *AASHTO Roadside Design Guide*. Fixed objects within the clear zone that warrant protection or removal are:

- Sign and luminaire supports with either a breakaway or yielding design greater than 1,100 lb.-sec. (linear impulse) or a concrete base extending 6 inches or more above the ground.
- Fixed sign bridge supports.
- Bridge pier and abutments at underpasses.
- Retaining walls and culverts.
- Trees or shrubbery with diameters greater than 6 inches.
- Wood poles or posts with a cross-sectional area greater than 50 square inches.
- Certain styles of mailboxes that are mounted on thin wall steel tubes that exceed 2 ½ inches in diameter or wood posts that exceed a 4-inch diameter or width. Mailboxes shall meet the US Postal Service requirements. Standard details for mounting and support/foundations can be found in Appendix 4B.

### 4.2.1.14.3 Non-traversable Hazard Criteria

Any non-traversable hazard within the clear zone that requires shielding by a barrier should be removed. If this is not practical, a barrier should be provided. Typical non-traversable hazards are:

- Rough rock cuts
- Large boulders
- Streams or permanent bodies of water more than 2 ft. in depth
- Shoulder drop-offs with slopes steeper than 1:1 and a height greater than 2 ft

### 4.2.1.14.4 Bridge Rail Ends, Transitions, and End Treatment Criteria

Most bridge rail approach barrier systems are some type of roadside barrier. For details on warrants for the protection of such roadside hazards, see the *AASHTO Roadside Design Guide*.

### 4.2.1.14.5 Ditch Section Criteria

Although specific criteria for barrier protection at ditches do not exist, they can be potential hazards if located near the traveled way and not traversable by an errant vehicle. Preferable front and back slopes for various ditch configurations are provided in the *AASHTO Roadside Design Guide*.

### 4.2.1.15 Permanent Barricades

The Alabama Department of Transportation Standard Drawings and Specifications shall be used for permanent barricade construction details.

### 4.2.1.16 Storm Drainage Control

See Section 6.0 of this Public Works Manual for the storm drainage requirements.

### 4.2.1.17 Transit Stops

Transit bus stops shall be constructed in accordance with the Federal Transit Authority (FTA) requirements and the City's standard details. The location shall be coordinated with the Phenix City Express (PEX).

## 4.3 INTERSECTION DESIGN ELEMENTS

### 4.3.1 Design Criteria

Intersections vary in complexity from a simple 4-leg intersection to a more complex intersection at which three (3) or more roads cross within the same area. Various elements and distractions at an intersection may prohibit a driver from safely and efficiently moving through the area. The following requirements and standards have been established to minimize the severity of potential conflicts between vehicles, pedestrians and bicyclists, while maintaining the smooth flow of traffic across the intersection.

#### 4.3.1.1 Angle of Intersection

Street intersections shall be at right angles, or as close to ninety degrees (90°)

as possible. Where, for topographic or other reasons acceptable to the City Engineer, an intersection cannot be at right angles, such intersection shall be as close to right angles as possible, and in no case shall be less than sixty degrees (60°). Intersections at angles less than sixty degrees (60°) are not permitted.

Street jogs at intersections with centerline offsets of less than one hundred twenty-five (125) feet shall not be permitted.

### **4.3.1.2 Development Entrances**

In order to ensure smooth traffic circulation on the site, directional signs and pavement markings shall be installed as outlined in the MUTCD, latest edition, in conjunction with the City and/or ALDOT.

The Highway Corridor Overlay District requirements shall be implemented in the designated areas as described in the Phenix City Zoning Ordinance.

#### **4.3.1.2.1 Signs**

No signs other than those required for traffic control shall be placed within the right-of-way nor be allowed to obstruct the view of traffic entering an intersection. All signs shall be installed in accordance with the Zoning Ordinance. The Engineering and Public Works Department and the Building Department shall review the application, plans and specifications to determine whether the proposed sign conforms to all applicable requirements. The Codes Enforcement Division must pre-approve structural drawings for all freestanding signs prior to issuance of a Sign Permit by the Building Department. Freestanding signs will also require a footing inspection by the Codes Enforcement Division.

Section 4.7 "Signing and Pavement Markings" contains additional information on street name signs and regulatory signs at development intersections.

#### **4.3.1.2.2 Landscaping**

All landscaping shall be installed in accordance with the Zoning Ordinance and the requirements of this Manual.

Landscaping proposed within State right-of-way shall be approved by ALDOT prior to installation.

#### **4.3.1.2.3 Islands**

Development entrance islands are to be constructed in a manner as to not

protrude into the right-of-way. A set back of ten (10) feet from the right-of-way is required. Islands should not be installed to contain existing infrastructure, i.e. power poles, signal poles.

An island width of four (4) feet to ten (10) feet is recommended, which should provide adequate refuge area for pedestrian and bicyclists. Medians more than twenty (20) feet wide may encourage wrong way traffic entering or exiting the development and increase the overall width of the intersection, which negatively impacts safety.

A mountable nose with a roll curb is required on all development entrance raised center islands. A detail is provided in the standard drawings in Appendix 4B of this document.

All landscaping within development entrance islands shall be installed in accordance with the Zoning Ordinance. Private irrigation equipment and piping shall not be placed within the City's right-of-way. Landscaping irrigation systems shall be installed with under drains to limit the impact on the adjacent street drainage system.

#### **4.3.1.2.4 Gates**

Gates are permitted on private development entrances and on public roads; however, the location and type should be such that stopped traffic is beyond the normal edge of pavement and must be approved by the Fire Code Official prior to installation. Gates shall meet the minimum requirements of the fire code as adopted by the City of Phenix City. The gate(s) location and relevant operational material must be provided during the City Engineer's review process.

#### **4.3.1.2.5 Water and Sanitary Infrastructure**

Unless otherwise approved by the Phenix City Utilities Department to allow utility access to other property through private property, all water and sanitary infrastructure located off of the public right-of-way shall be private and privately maintained. Water meters shall be placed within the public right-of-way except when prohibited by ALDOT in which case the meters shall be placed directly adjacent to said right-of-way within an easement dedicated to the City of Phenix City.

#### **4.3.1.3 Sight Distance**

To provide a clear view of intersection streets to the motorist, there shall be a sight triangle or triangular area of clear vision formed by two (2) intersecting streets. The sight triangle for intersecting streets shall be as identified in the

AASHTO Green Book, latest edition. The size of this sight triangle is a function of maneuver, traffic control, speed and design vehicle. Roundabouts, signalized intersections or all-way stop controlled intersections may require less sight distance.

DRAFT

**Figure 4.5 Intersection Sight Triangles**

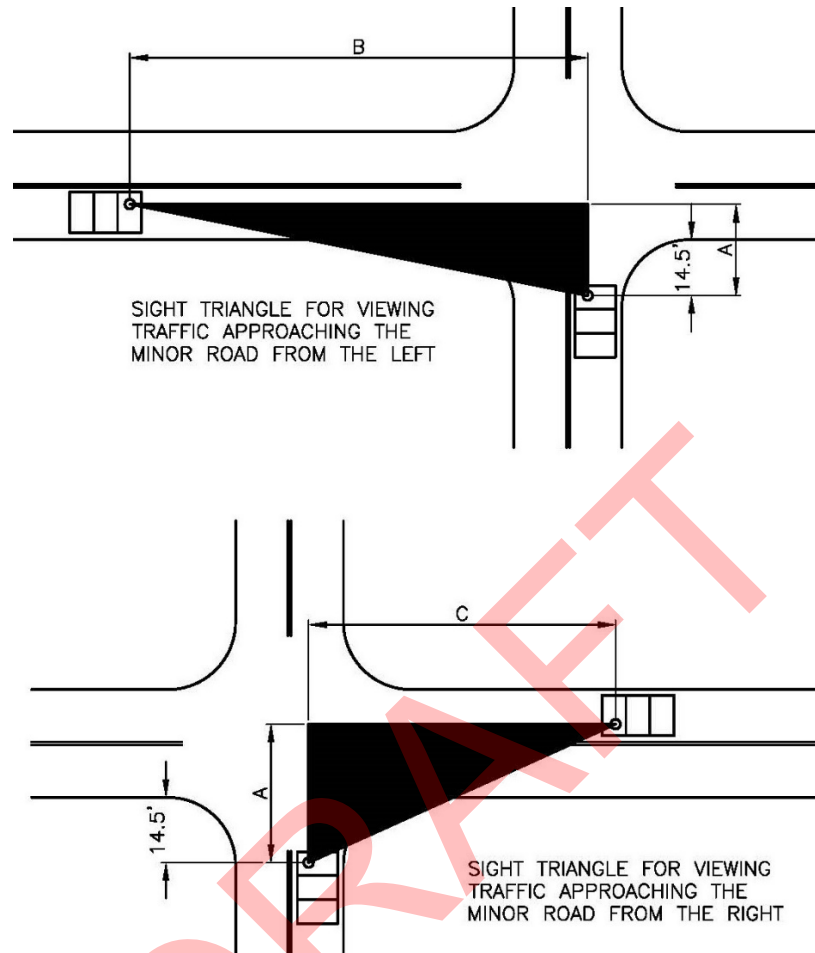

Figure 4.5 Intersection Sight Triangles illustrates the required distance for a stopped vehicle on a minor road to turn left, turn right or cross the intersection. The sight triangle for viewing traffic approaching from the left is required for all three (3) movements; the sight triangle for viewing traffic approaching from the right is required for left turn and crossing movements.

The length of the sight triangle along the minor road is the sum of the distance from the major street plus one half (0.5) lane width for vehicles approaching from the left, or one and one half (1.5) lane width for vehicles approaching from the right. A distance of fourteen and one half (14.5) feet from the major road is recommended, as it represents the position of the driver on the minor road. The distance for vehicles approaching from the left should be fourteen and one half (14.5) feet plus one half (0.5) lane width, regardless of the number of lanes. For vehicles approaching from the right on multilane roadways, the distance should be measured to the center of the inside travel lane.

The length of the sight triangle on the major road is based on the sight distance required for a stopped passenger car to either turn left, turn right or cross a two-lane highway with no median with a grade of three (3%) percent or less on the minor approach. If there are any variations to this condition, the time gap shall be modified, and the required sight distance must be recalculated as per AASHTO. The design speed used to determine the required intersection sight distance should be based upon the prevailing posted speed plus ten (10) miles per hour or the 85<sup>th</sup> percentile speed, whichever is greater. The sight distance triangle shall also apply to development entrances and driveways.

**TABLE 4.9 Design Intersection Sight Distance**

Design Speed (mph)	Design Intersection Sight Distance (ft)	
	Left Turn from Stop (C)	Right Turn from Stop / Crossing Maneuver (B)
15	170	145
20	225	195
25	280	240
30	335	290
35	390	335
40	445	385
45	500	430
50	555	480
55	610	530
60	665	575
65	720	625
70	775	670

Source: AASHTO *Geometric Design of Highways and Streets, 2018*

**4.3.1.4 Roundabouts**

Roundabouts shall be designed in accordance with the latest guidelines from FHWA. The following table describes the basic design elements by roundabout categories that are acceptable for use within the City. In some cases, larger radii and roadway turning widths may be required and will be noted during the design review process.



**TABLE 4.10 Roundabout Design Elements**

Category	Recommended Maximum Entry Design Speed	Typical Inscribed Circle Diameter*	Typical Design Vehicle
Urban Single-Lane	20 mph	100 – 130 ft	WB-50 (42.5' trailer)
Urban Double-Lane	25 mph	150 – 180 ft	WB-50 (42.5' trailer)

\* Assumes 90° angles between entries and no more than four legs.

Source: FHWA Publication No. FHWA-RD-00-067 Roundabouts: An Informational Guide, 2000

#### 4.3.1.4.1 Geometric Characteristics

The inscribed circle diameter is the distance across the roundabout, from outside edge of pavement to outside edge of pavement. The diameter must be wide enough to accommodate the design vehicle while maintaining adequate curvature to deflect a passenger car and ensure a safe traveling speed. In general, the inscribed circle diameter of one hundred (100) feet is the minimum to accommodate a WB-50 design vehicle. Smaller roundabouts can be used on some local and collector streets where the design vehicle may only be a single-unit truck or a bus.

Entry and exit curves are dependent on the maximum design speed. The objective is to create speed consistency to reduce the crash severity and simplify the task of merging. Exit curves usually have larger radii than entry curves to minimize congestion at the exits.

#### 4.3.1.4.2 Sight Triangle

The sight triangle for a roundabout should be assumed to follow the curvature of the roadway and should be measured as distances along the vehicular path of the conflicting approaches. The sight distance “triangle” has two (2) conflicting approaches that must be checked independently. The entering stream is comprised of vehicles from the immediate upstream entry. The circulating stream is comprised of vehicles that entered the roundabout prior to the immediate upstream entry. It is recommended to provide no more than the minimum required intersection sight distance on each approach.

#### 4.3.1.4.3 Landscaping

A standard roundabout may contain drought tolerant landscaping or hardscape. A tree may be positioned in the center of a roundabout on a local street as necessary for visibility concerns if approved by the City Engineer. Trees are not allowed to be installed in the center of a roundabout on State Routes. Vegetation will be installed as designated by the City Engineer. A water spigot may be included as standard

landscaping for maintenance of vegetation. Any necessary property dedication or landscape maintenance agreement shall be completed prior to final project design.

### 4.3.2 Left Turn Lane Warrants at Unsignalized Intersections

High volumes of left turns may warrant construction of left turn lanes on two-lane and multi-lane roadways at unsignalized intersections. Left turn lane warrants are governed by the volume of opposing traffic, the volume of advancing traffic, the percentage of left turns in the advancing volume and the speed of the roadway. Appendix D of the *ALDOT Access Management Manual* contains a Left/Right Turn Lane Quick Guide that can be used as an initial screening tool to determine if a turn lane should be considered based on traffic volumes. A copy of the ALDOT Left/Right Turn Lane Quick Guide is included in Appendix 4F.

A detailed traffic study or a development specific turn lane warrant based on the procedures documented in NCHRP Report 457 maybe be required to determine whether a left turn lane is required should the applicant not concur with the ALDOT Left/Right Turn Lane Quick Guide.

The warrants for the recommended installation of a left turn lane on a two-lane roadway are illustrated in Figures 4.4, 4.5 and 4.6 for forty (40) mph, fifty (50) mph and sixty (60) mph respectively. For speeds of forty-five (45) mph use the warrant for fifty (50) mph and for speeds of fifty-five (55) mph use the warrant for sixty (60) mph. For speeds less than forty (40) mph, use the warrant for forty (40) mph (Figure 4.6). The warrant for the installation of a left turn lane on a four-lane undivided roadway is illustrated in Figure 4.9.

**Figure 4.6 Left Turn Lane Warrants on Two-Lane Roadways 60 km/h (40mph)**

Source: National Cooperative Highway Research Program (NCHRP) Report 457 Evaluating Intersection Improvements: An Engineering Study Guide, 2001, Figure 2.5

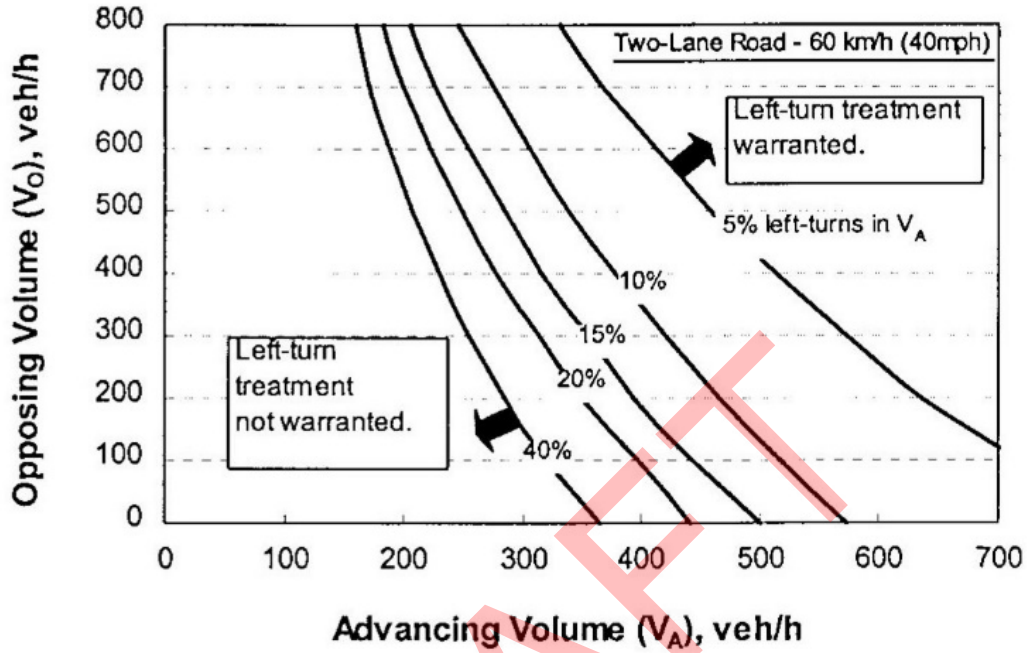

**Figure 4.7 Left Turn Lane Warrants on Two-Lane Roadways 80 km/h (50mph)**

Source: National Cooperative Highway Research Program (NCHRP) Report 457 Evaluating Intersection Improvements: An Engineering Study Guide, 2001, Figure 2.5

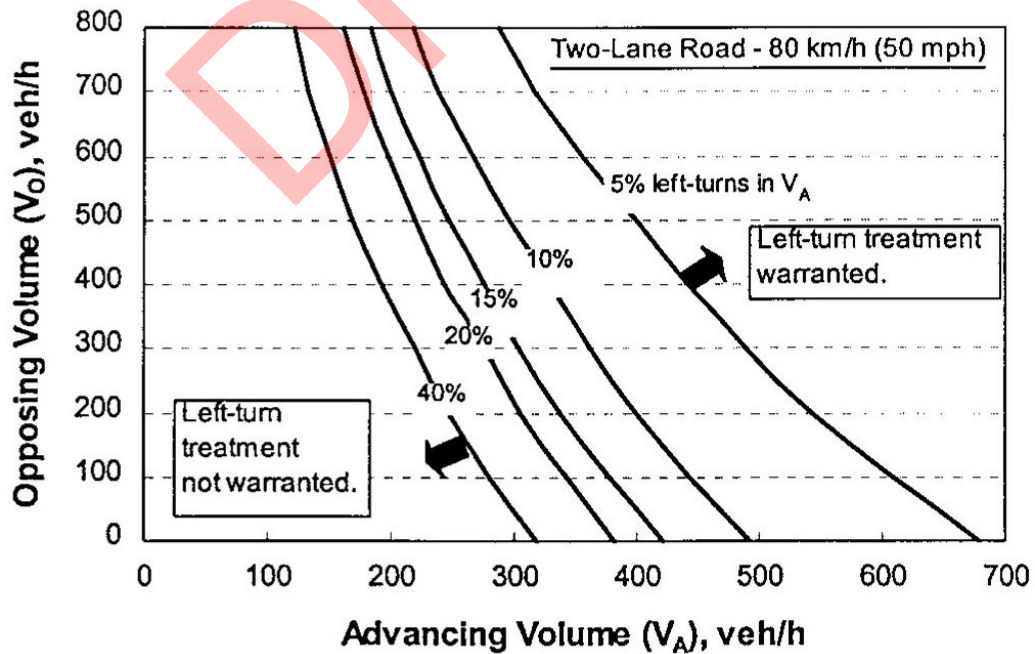

**Figure 4.8 Left Turn Lane Warrants on Two-Lane Roadways 100 km/h (60mph)**

Source: National Cooperative Highway Research Program (NCHRP) Report 457 Evaluating Intersection Improvements: An Engineering Study Guide, 2001, Figure 2.5

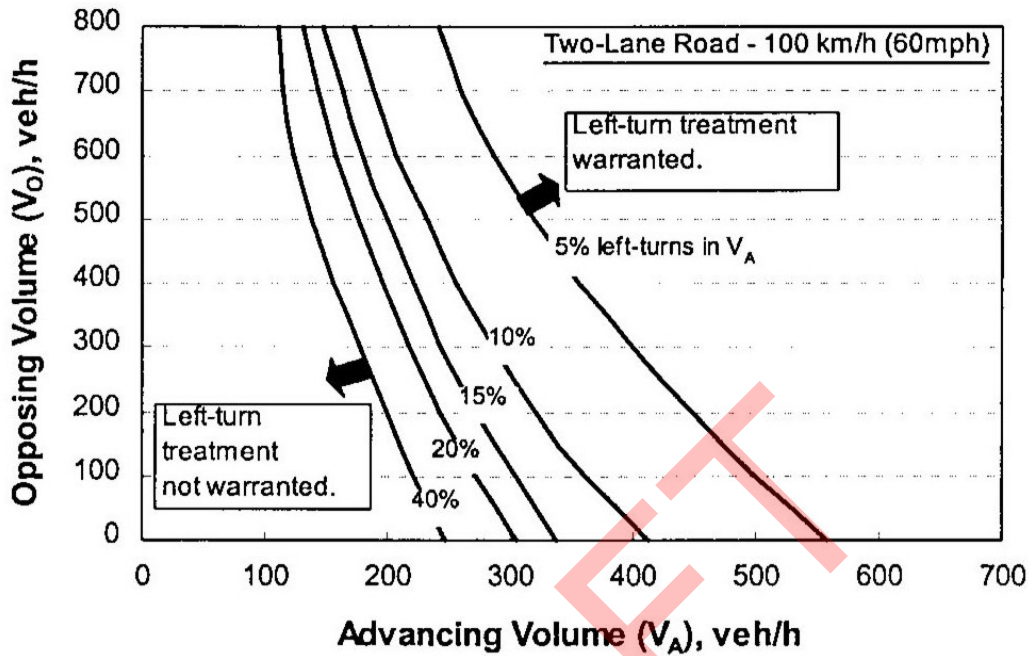

**Figure 4.9 Left Turn Lane Warrants on Four-Lane Undivided Road**

Source: National Cooperative Highway Research Program (NCHRP) Report 457 Evaluating Intersection Improvements: An Engineering Study Guide, 2001, Figure 2.5

Note: When  $V_o < 400$  veh/h (dashed line), a left-turn lane is not normally warranted unless the advancing volume ( $V_A$ ) in the same direction as the left-turning traffic exceeds 400 veh/h ( $V_A > 400$  veh/h).

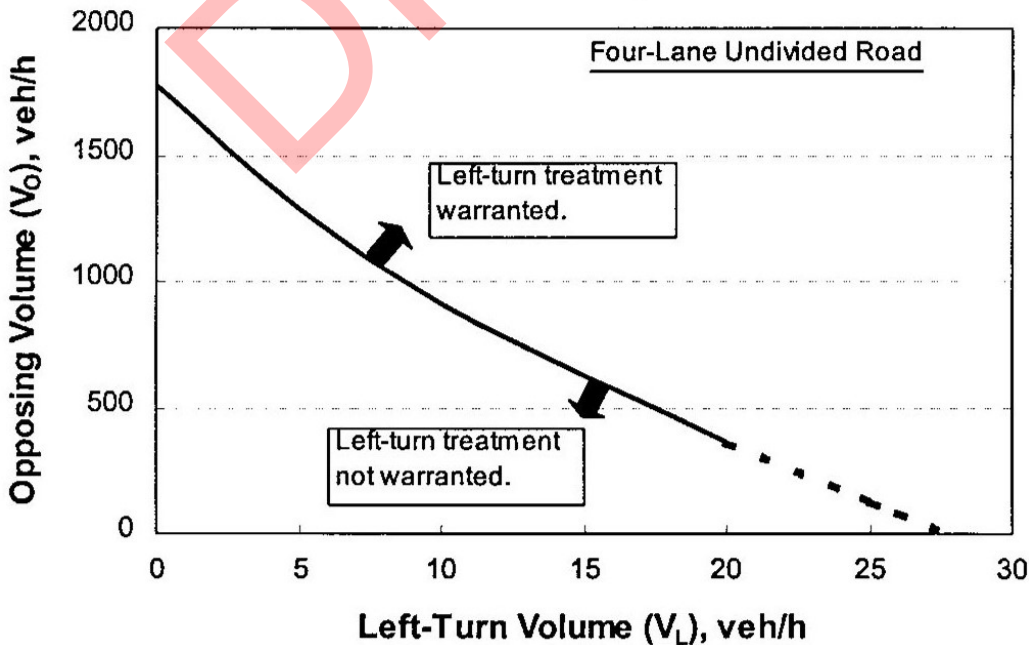

### 4.3.3 Left Turn Lane Warrants at Signalized Intersections

Left turn lanes are required at all connections on median divided roadways and at all signalized intersections in the City. Left turn lanes at other locations shall meet the left turn lane warrant requirements outlined in Chapter 4 of the ALDOT *Access Management Manual*. Documentation shall be submitted during the City Engineer's review process.

### 4.3.4 Right Turn Lane Warrants

High volumes of right turns generated by developments may warrant construction of right turn lanes on two-lane and multi-lane roadways. Figures 4.8 and 4.9, published in the NCHRP Report 457 *Evaluating Intersection Improvements: An Engineering Study Guide, 2001* can be consulted to provide guidance for including right turn lanes.

Right turn lanes shall meet the right turn lane warrant requirements outlined in Chapter 4 of the ALDOT *Access Management Manual*. Appendix D of the ALDOT *Access Management Manual* contains a Left/Right Turn Lane Quick Guide that can be used as an initial screening tool to determine if a turn lane should be considered based on traffic volumes. A copy of the ALDOT Left/Right Turn Lane Quick Guide is included in Appendix 4F. Documentation shall be submitted during the City Engineer's review process.

#### Figure 4.10 Right Turn Lane Warrants on Two-Lane Roadways

Source: National Cooperative Highway Research Program (NCHRP) Report 457 *Evaluating Intersection Improvements: An Engineering Study Guide, 2001, Figure 2.6*

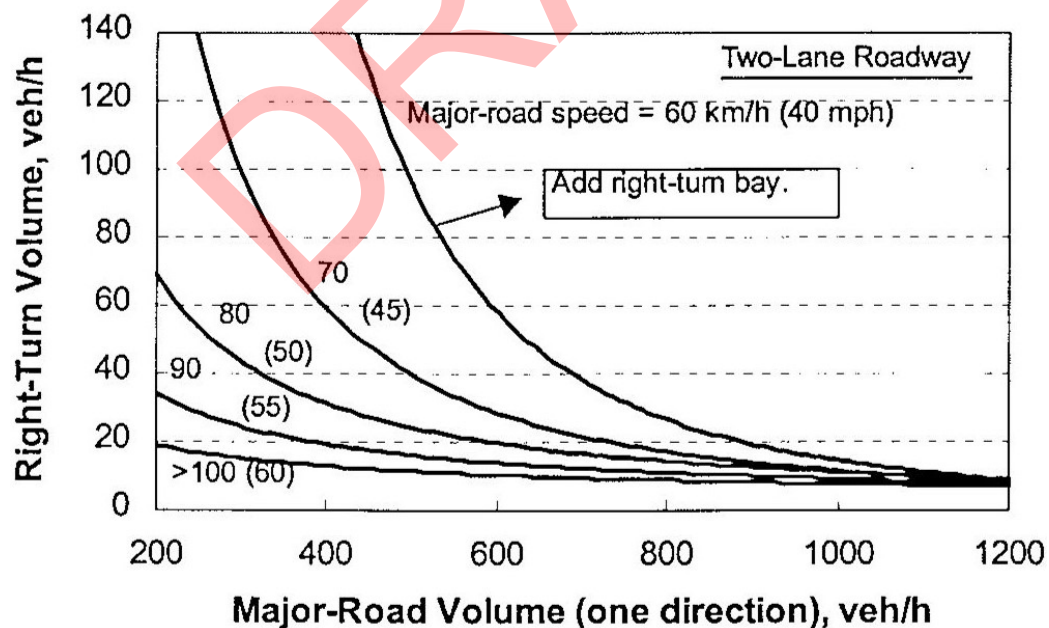



**Figure 4.11 Right Turn Lane Warrants on Four-Lane Roadways**

Source: National Cooperative Highway Research Program (NCHRP) Report 457 Evaluating Intersection Improvements: An Engineering Study Guide, 2001, Figure 2.6

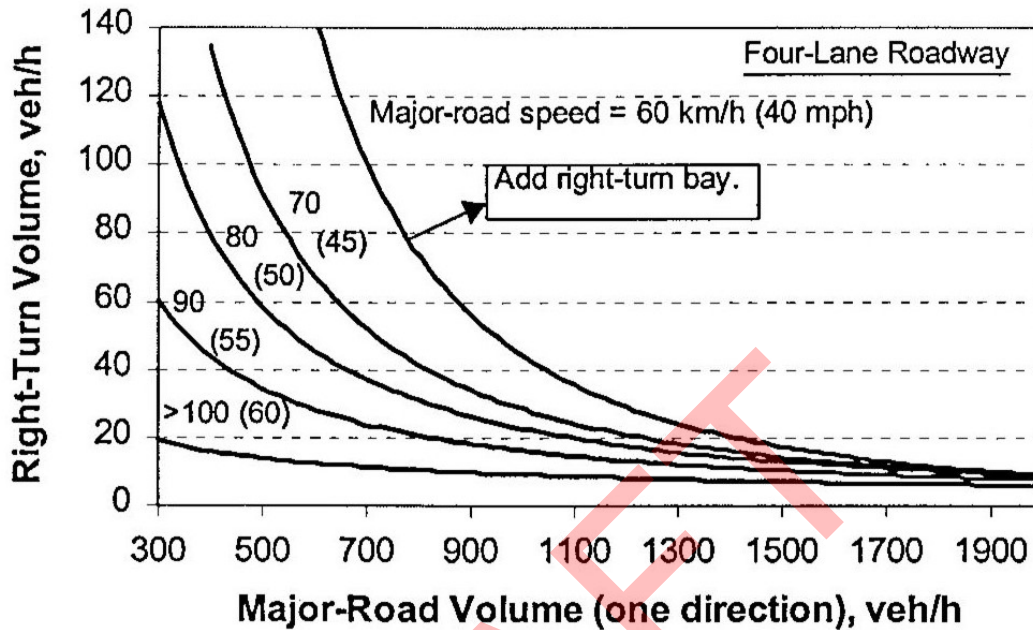

Design requirements for fullwidth right turn lanes are discussed in Section 4.3.5 “Deceleration Lanes and Tapers.” Where taper turn lanes are warranted, the lengths shown in Table 4.11 are required to provide sufficient length for a vehicle to decelerate and brake entirely outside the through travel lanes.

**TABLE 4.11 Deceleration Lane Standards**

Source: National Cooperative Highway Research Program (NCHRP) Report 279 Intersection Channelization Design Guide, 1985

Design Speed (mph)	Length of Taper (ft)*
30	235
40	315
50	435
60	530
65	570
70	615

\* Appropriate for right turn lanes on approaches to stop signs and traffic signals.

### 4.3.5 Deceleration Lanes and Tapers

Deceleration lanes shall be required at all permitted access points along an arterial or collector roadway in the City as specified in Appendix 4A, unless a right turn warrant or traffic impact study determines the deceleration lane is not needed. Additionally,

deceleration lanes may be required on collector roadways in those areas where congestion is anticipated, and the capacity of the roadway would be impacted. Deceleration lane and taper lengths for both right and left turn lanes shall be constructed in accordance with Table 4.12 and Figure 4.12.

**TABLE 4.12 Deceleration Lane Standards**

Posted Speed (mph)	Taper Length d1 (ft)	Deceleration Length d2 (ft)	Storage Length* d3 (ft)	Minimum Total Length (ft)
25	75	35	25	135
30	95	65	25	185
35	110	100	25	235
40	130	140	25	295
45	150	195	25	370
50	165	255	25	445
55	185	320	25	530
60	205	395	25	625
65	225	480	25	730

\* Storage Length determined by Traffic Impact Study – Minimum 25 ft.

**Figure 4.12 Deceleration Lane Standards**

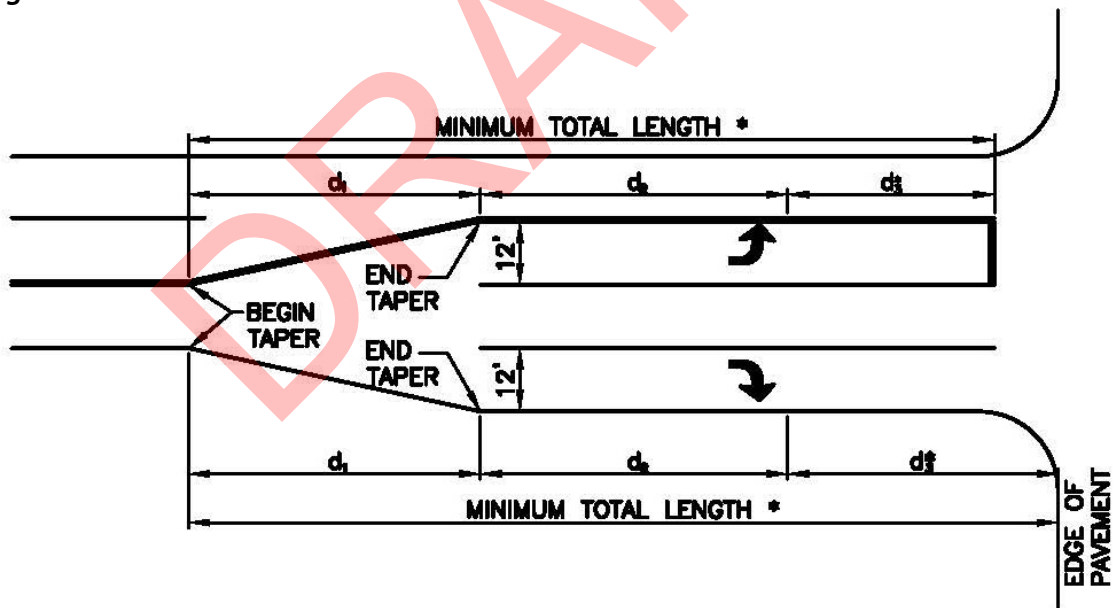

A continuous right-turn lane may be required where driveway spacing requirements restrict the use of consecutive turn bays and tapers and where it is determined by the City and/or ALDOT that the lane would not be used as a through lane.

When a development warrants the widening of the roadway that will alter the current pavement markings, the developer, at his or her expense, shall provide a three-

quarter (0.75) inch mill and overlay. The limits of the overlay shall cover all travel lanes and will begin and end at the limits of all roadway improvements.

### 4.3.6 Left Turn Lanes on Divided Roadways

On roadways where medians currently exist, the construction of a median opening at a private access point will require approval of the City Council prior to construction. Construction of a left turn lane at a new median opening shall be done so in accordance with Table 4.11.

Left turn lanes, if not present on divided roadways at current median openings, will be constructed by entities requesting permits for private driveways and/or public streets that align with such driveways. Left turn lanes are required on the City's arterial and collector roads unless unusual circumstances exist as justified by the Applicant's engineer and approved by the City Engineer.

## 4.4 DESIGN OF PAVEMENTS

The design criteria outlined below shall take precedence over the ALDOT standard specifications except on State routes. For items not covered by these criteria, the current edition of the ALDOT standard specifications and special provisions shall apply.

### 4.4.1 Design Criteria

#### 4.4.1.1 New Construction

All roadway pavements shall be constructed in accordance with the ALDOT Construction Manual and shall be approved by the City Engineer. Roadways designated for access by fire apparatus shall be capable of supporting the imposed load of the fire apparatus weighing up to 75,000 pounds (34,050 kg).

##### 4.4.1.1.1 Local Streets

All roadway pavements shall be asphalt and constructed in accordance with the design guidelines provided herein. Alternatives to the full depth pavements or variance to the listed thickness will be considered on a case-by-case basis, based on subgrade soils and/or expected traffic.

A two (2) inch bituminous binder, a one (1) inch wearing surface and a prime coat on a suitable graded aggregate base six (6) inches thick on a properly drained and compacted sub-grade is required. The top six (6) inches of the sub-grade shall be compacted to meet 100% of the standard proctor density.

Interface of curb and asphalt shall be coated with tack prior to placement



of asphalt. Tack coat shall be placed between asphalt layers in accordance with ALDOT specifications.

All pavement shall meet ALDOT Standard Specifications Section 424. Minimum plant mix requirements for all residential streets will be as follows:

Binder - 220 lbs. per square yard with a  $\frac{3}{4}$ " maximum aggregate size

Wearing Surface - 110 lbs. per square yard with a  $\frac{1}{2}$ " maximum aggregate size

Greater thickness and aggregate sizes may be required dependent upon street classification. Should any problem be encountered with the sub-grade, base, or binder layers, or should heavy construction traffic be projected following road construction, the City Engineer may require that the placement of wearing surface be delayed for a period of up to six (6) months. If problems are encountered relative to pavement thickness, coring or plant mix may be required.

On all roadways, the wearing surface shall not be applied until at least nine (9) months to no more than one (1) year after the binder has been properly installed. Before the wearing surface is applied, all work previously required shall be repaired to meet minimum City standards.

### **4.4.1.1.2 Arterials and All Collectors**

All asphalt roadway pavements shall be constructed in accordance with the design guidelines provided herein.

All required pavement buildups will be determined by the anticipated traffic volumes, including truck volumes. Equivalent Single Axle Loads (ESALs) will be calculated and will be used to determine the required structural number for a buildup. Equivalent buildups may be used if adequate documentation is supplied and approved by the City Engineer.

### **4.4.1.2 Pavement Repairs/Retrofit**

All roadway pavements shall be repaired in accordance with the design guidelines provided herein. A temporary patch must be placed immediately following the work and be in place at least forty-five (45) days prior to placing the final wearing surface. The temporary patch width includes a minimum of six (6) inches on either side of the trench as shown on the standard details in Appendix 4B. The exact limits of the permanent patch shall be determined by the Engineering and Public Works Department.

For resurfacing of streets, a minimum of thirty (30) foot milled area is required at the extents of paving on each street.

For permanent repairs to asphalt pavement, deep patches shall be removed at least four (4) inches in depth, to a depth at which firm support is reached. It may be necessary to remove some of the subgrade to reach this depth. The width should extend at least one (1) foot beyond the affected pavement area. Edges shall be vertical and smooth. A tack coat should be applied to all vertical faces of the patch.

The wearing surface repair shall include the trench width plus a minimum of an additional twelve (12) inches on either side to provide a smooth tie in.

### 4.4.1.3 Subgrade Construction

Finish grade shall conform to the lines, grades and cross-section as shown on the approved plan unless specific permission is acquired in writing from the City Engineer. The top six (6) inches of the sub-grade shall be compacted to meet 100 percent of the standard proctor density in accordance with Section 238 of the ALDOT specifications and as determined by ASTM designation D-1557, as revised from time to time. Sub-grade materials between six (6) to twelve (12) inches below the top of the sub-grade shall be compacted to meet 98 percent of the standard proctor density, and sub-grade materials below the top twelve (12) inches shall be compacted to a 95 percent of modified Proctor density as determined by ASTM designation D-1557.

### 4.4.1.4 Base

Prior to placing any base material, the subgrade shall be prepared and tested. The type of material to be used for base and required thickness shall be stated on the approved plan.

Base material consisting of crushed rock, stone particles, or slag shall contain an approved filler of sand or other fine mineral filler. Required six (6) inch base of this material shall be spread without segregation and may be placed and compacted to full depth in one (1) layer. Required base layers greater than six (6) inches shall be placed in approximately equal layers. Compaction shall be by vibratory, steel wheel rollers or other approved rollers to obtain a density of 100 percent when tested as determined by ALDOT standards method. In place density method pursuant to ALDOT standards may be used.

## 4.4.2 Maintenance Process

The subgrade and each base layer shall be maintained free of ruts, ridges, holes and true to grade until the next overlying layer is placed or the project is accepted in accordance with Section 8.4 of this Manual.

Any failures or defects in pavement layers shall be immediately repaired.

### **4.5 DESIGN OF UTILITIES IN STREET RIGHT-OF-WAY**

The design of new or relocated utilities shall comply with the codes and standards of appropriate technical organizations and jurisdictions. The City Engineer shall be notified of any utility installations or repairs (underground or overhead facilities) in which the work will affect the flow of traffic. The ALDOT District Engineer shall be notified of any utility work affecting traffic on state roadways in the City.

The City of Phenix City has adopted a policy to require underground installation of wires and facilities for the supply of electric, communication or related services within the corporate limits of Phenix City. The subdivider, developer or owner of any such area or a portion thereof shall make the necessary arrangements and payment for the installation of underground facilities, including circuits for streetlights. Such arrangements shall be made with each of the companies or persons supplying the electrical and/or communication service therein, in accordance with the established rules, policies and charges of such company or persons. Exceptions shall be as stated in the adopted Regulations for Underground Utilities.

The installation, placement or maintenance of any and all underground electrical or communication wiring or associated structures or facilities, whether they be above or underground, shall be prohibited in all floodplains, flood prone areas, drainage easements, major drainageways, or any other area where the possibility of standing water exists. Where electrical or communication service wiring must cross such areas, easement or ways, they must be elevated and so installed as to be reasonably free from flood or storm water runoff damage.

#### **4.5.1 Permits**

No person, except in the case of an emergency, shall make any tunnel, opening or excavation of any kind in or under the surface at any street or right-of-way maintained by the City of Phenix City without first securing a permit from the City for each separate undertaking. In the case of an emergency, this permit shall be applied for on the next regular business day. The Application for Installation of Underground Utility Permit can be found in Appendix 4G or obtained from the office of the Engineering and Public Works Department.

Each utility shall provide the City of Phenix City with a complete set of construction plans prior to receiving an Installation of Underground Utility Permit.

The City of Phenix City has implemented a permit fee schedule required of permittees to recover the costs associated with inspecting and monitoring street openings, excavations and cuts, and the increased maintenance and repair costs caused by said street openings. The applicable charges and fees can be obtained from the City

Engineer.

### 4.5.1.1 Warranty and Permittee Responsibilities

Trenches/cuts in roadways shall be warranted by the permittee for a period of one (1) year after the permanent patch is accepted by the City. The permittee shall notify, in writing, the Engineering and Public Works Department that the permanent patch has been placed and is ready for inspection/acceptance.

The Engineering and Public Works Department shall inspect the patch for quality of workmanship and acceptability of material. The inspection must take place before the warranty period can begin.

The Engineering and Public Works Department shall keep a list of the date that the permitted work is completed as reported by the permittee. The date that the Department receives the notice of completion shall begin the one (1) year warranty period for roadway patches. At the end of the warranty period the Engineering and Public Works Department will notify the permittee that the warranty has expired. The warranty shall expire on the last day of the month in which the permittee notifies the Engineering and Public Works Department that the work has been completed. The warranty period shall not begin until the Department receives notification of the work completion in writing. Notification of completion shall be submitted in a formal letter on the permittee's letterhead. Until such notification is received the permittee remains responsible for the roadway patch.

Failure of a patch due to causes other than base and paving failure shall be addressed as noted below. If failures of the patch are caused by failures of a buried utility, then the owner of the utility is responsible as noted below:

- Failure of roadways due to failure of structures such as manholes, valve boxes, pipes, conduits, etc., shall be the responsibility of the owner of the structures. The owner is expected to repair the damaged roadway as well as the structure to the satisfaction of the City Engineer.
- Failure of patches after one (1) year warranty period that occur due to decay or failure of a utility structure, for whatever reason, shall be the responsibility of the owner of the structure to repair.

## 4.5.2 Design Criteria

### 4.5.2.1 General Locations

Public utilities shall be located within the right-of-way and in accordance with the preferences and specifications provided by the city. Utility and drainage easements may be combined, subject to approval by the City Engineer and shall

be at least thirty (30) feet wide, fifteen (15) feet on each side of the property lines of lots. The easement widths shall be extended when necessary to provide space for utility bracing and other construction.

The preferred location for the water main is on the north and east sides of the streets. Sanitary sewer mains, services and appurtenances owned and/or maintained by the City shall be within a dedicated easement or City right-of-way. Water lines shall be installed so that they cross over the top of the sanitary and storm sewers. Refer to Section 7 for guidance on the design and construction of potable water and sanitary sewer owned and/or maintained by the City.

Where feasible and appropriate, utility companies shall indicate the locations of their underground structures by means of "surface markings." Utility markings shall be placed on curb face and gutter, per the adopted Underground Utilities Policy of the City of Phenix City.

Easements are required in situations where utilities cannot be placed within the right-of-way, or covered by an existing easement, and must be installed on private property. The standard easement width is based on two (2) times the depth of cover, rounded up to the nearest multiple of ten (10) feet, with a minimum width of twenty (20) feet wide centered on the utility. Upon recommendation of the City Engineer, the City may require public easement for poles, wires, conduits, storm and sanitary sewers, gas and water lines, and similar public services and utilities. Such easements will typically be twenty (20) feet in width unless additional area is needed. For consideration of future maintenance activities, the City prefers that easements be placed to the side of the lot line rather than centering on lot lines. The width of the easements shall be increased or extended, where necessary, to provide spaces for utility pole bracing or other construction and maintenance.

All water and sewer utility easements shall be dedicated to the City as Drainage and Utility Easements unless otherwise approved and shall not be combined with any other utility easements (i.e., gas, electric, communications, etc.). Water and sewer easements separate from roadway right-of-way are exclusive and are not to be used to install any other non-City owned and maintained utility. Utility easements can be combined with drainage easements subject to approval by the City Engineer. Where other utilities must be installed inside a water or sewer easement, and where approved by the City Engineer and the Utilities Director, an Easement Encroachment Agreement will be required with the encroaching utility, as discussed in Section 1.4.5 - Dedications of this Manual.

### 4.5.2.2 General Requirements

The integrity of the roadway pavement structure and side slopes is the primary

concern for utility construction within the City’s right-of-way. The following guidelines have been prepared to address this concern for all utilities contained within the City’s right-of-way. Figure 4.13 shows the standard utility locations.

**Figure 4.13 General Utility Locations**

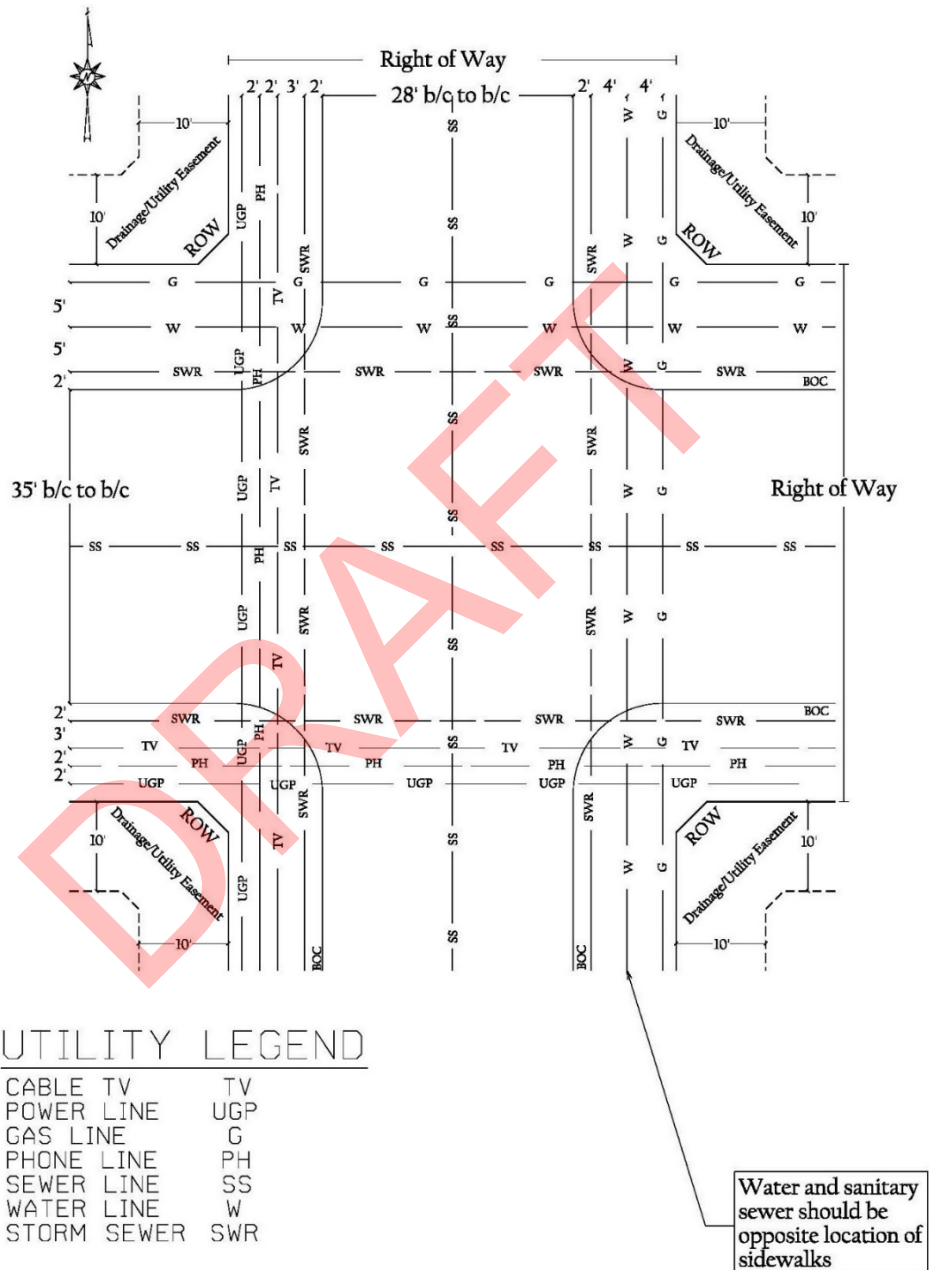

**4.5.2.2.1 Electric Installations**

All electric installations shall be in accordance with rules and regulations of the Alabama Public Service Commission and the National Electric Safety Code.

### 4.5.2.2.2 Pipe Cover

Every pipe or conduit for water, sewage, gas, drainage, communication or any other use shall have a minimum cover of thirty (30) inches under the roadway pavement unless otherwise approved by the City of Phenix City.

### 4.5.2.2.3 Excavation and Backfill Requirements

Excavation and backfill activities shall be conducted in accordance with the adopted Underground Utilities Policy of the City of Phenix City, as applicable.

Excavated material shall be placed in an area to maintain access to both public and private property except during working hours when construction operations prohibit provision of such access. Free access must be provided to fire hydrants at all times.

Pipe drains, pipe culverts or other facilities encountered during excavation work shall be protected.

Every permittee shall place around the project work area such barriers, lights, warning flags and danger signs as shall be determined by the City Engineer and in compliance with the MUTCD to protect the public.

If deposited along open trenches, material shall be laid compactly along the side of the trench and kept trimmed. The material shall be placed such that in the event of rain there is no damage to the work or the property adjacent to the project. Depending on the duration of the work, a temporary crossing may be required to maintain vehicular or pedestrian traffic. If the excavated area is muddy and causes inconvenience to pedestrians, temporary wooden plank walks shall be installed. If the street is not wide enough to hold the excavated material without using part of the adjacent sidewalk, the permittee shall keep a passageway at least one-half of the sidewalk width open along such sidewalk line.

The width of the trench shall be as wide as deemed necessary by the contractor to assure safe working conditions in accordance with OSHA rules and regulations.

All pavement cuts, openings and excavations shall be properly made, backfilled, compacted and temporarily surfaced by the permittee according to the City of Phenix City specifications.

All work is subject to inspection by the City of Phenix City Engineering and

Public Works Department and Utilities Department.

### 4.5.2.2.4 Open Cut Installation

Open Cut of a roadway is prohibited for new installations unless site conditions warrant it or as otherwise approved by the Engineering and Public Works Department. The open cut method may be used for repair of existing facilities. Private driveways may be open cut with the approval of the City Engineer provided that access is maintained to the property during the work. The City will consider open cut installation on local roadways or cul-de-sacs that have not been paved or resurfaced within the last five (5) years and access can be maintained during the entire installation process. All other street classifications will require trenchless utility installation.

Patching will be permitted on days when weather is satisfactory. When placing concrete, the temperature of the air shall be forty degrees (40°) and rising. When placing asphalt, the temperature of the air shall be forty degrees (40°) and rising.

All trench/cut shall be excavated to the minimum size as specified in this Manual, depending on the type of patching used for final closure. Narrower trench/cut may be approved by the Engineering and Public Works Department if smaller compaction equipment is available. All backfill shall be tamped in 6-inch lifts, to 100% of the standard proctor density. Compaction testing shall be done in accordance with Section 8.4.

No cleated equipment is to be used on paved surfaces. Special care shall be taken to protect pavements from damage by equipment.

All cuts shall be made to maintain a square or rectangular configuration. No round cuts will be accepted.

#### 4.5.2.2.4.1 Asphalt Cuts

The preferred method of cutting streets is to saw cut the asphalt. However pneumatic tools such as jack hammers may be used if the appearance of the cuts is satisfactory to the Engineer. When cutting of asphalt is allowed by methods other than sawing, the requirement for straight cuts with vertical sides shall not be waived. All cuts shall be smooth, uniform cuts. If ragged or jagged edges are left or vertical sides are not apparent on the cut, then sawing or otherwise smoothing the face of the cut shall



be done by the permittee. No cut shall be less than 2 feet by 2 feet on the surface, to allow for proper patching and compaction.

### **4.5.2.2.4.2 Concrete Cuts**

All cuts in concrete paved surfaces shall be saw cut smoothly in a square or rectangular shape. No round cuts will be accepted.

### **4.5.2.2.4.3 Installation in Unpaved Streets**

Utilities under an unpaved street may be installed by open cut and backfilled in accordance with the following method:

1. The trench/cut shall be backfilled in 6-inch lifts using native material if deemed acceptable by the inspector. Alternate backfill materials may be substituted with prior written approval from the Engineer. All Backfill material shall be compacted to 98% of the standard proctor density for the entire depth of the trench/cut. Moisture shall be added to each lift as needed as the trench/cut is filled in order to achieve maximum compaction.
2. The trench/cut shall be filled with native or pre-approved material and compacted then a temporary patch shall be placed as described in Section 4.5.2.2.4.4.
3. Once the trench/cut is filled and temporary patch material is placed, then the roadway may be opened for traffic.
4. Upon approval by the Engineer, the permittee may substitute Crushed Aggregate Base material as defined in the Alabama Department of Transportation Standard Specifications for Highway Construction, current edition.

### **4.5.2.2.4.4 Asphalt Patches**

Asphalt patches shall be completed in accordance with the following method:

1. The permittee shall fill the trench/cut to within nine (9) inches of the roadway surface then place six (6) inches of Crushed Aggregate Base and place three (3) inches of the approved "cold mix" as a temporary patch. The

roadway then maybe opened to traffic. See Temporary Patch Detail in Appendix 4B.

2. Within forty-five (45) days of placement of the temporary patch material, the permittee shall excavate the patch to a depth of six (6) inches below the surface of the roadway, and place four (4) inches of binder and two (2) inches of hot mix asphalt as a permanent patch. See Permanent Patch Detail in Appendix 4B.

#### 4.5.2.2.4.5 Resurfacing/Permanent Patches

The permittee may be required to resurface all or portions of roadway where work has been performed. Roadways that are identified on the "Reconstruction List" for the City shall not require resurfacing by the permittee. Roadways that are not listed on the "Reconstruction List" shall be resurfaced by the permittee when they meet the following criteria:

- In a block where linear cuts, running parallel to the centerline of the street and where these cuts extend more than 30% of the entire block length, the permittee responsible for these cuts shall at their expense resurface the street within the block affected.
- In a block in which three (3) or more street openings are made by a single permittee, owner, developer or their designated contractor. The permittee, owner or developer responsible for these cuts shall, at their expense, resurface the affected area. The exact limits shall be determined by the Engineering and Public Works Department. This shall apply to all streets not on the "Reconstruction or Resurfacing List."
- The Reconstruction or Resurfacing List shall be furnished to all stake holders who request it annually. The list will contain a prioritized list of streets that the City hopes to resurface with in the coming two (2) fiscal years. Should priorities change the same stake holders will be notified by the City by receiving an updated list of the street priority.

The resurfacing layer shall consist of a minimum of a one and one half (1½ inch) mill and overly with a Superpave Bituminous Concrete, ¾" Maximum Aggregate Size Mix (165 lbs/square yard). Other mixes may be approved by the Engineer as needed. The resurfacing shall extend for the entire affected

block length and shall be a minimum of one lane wide and a maximum the entire roadway width. The actual length of overlay may be adjusted at the discretion of the City Engineer. The resurfacing requirement may be waived if the street is programmed for Resurfacing or Reconstruction.

Cutting of roadways within the first 2-year period following an overlay is prohibited without written permission of the City Engineer. Emergency cuts within a 2-year period on roadways that have been resurfaced may require the permittee to resurface a portion of that roadway at his expense. A cut shall be defined as excavation of the roadway surface that is a minimum of 2 feet by  $\frac{1}{2}$  the width of the travel lane. "Pot holing" for locations of underground utilities prior to trenchless installations are not considered cuts.

#### **4.5.2.2.4.6 Driveway Replacement**

Driveways are to be replaced in accordance with standard details for driveway installation. Details may be obtained from the City Engineering and Public Works Department. When an existing driveway must be cut and removed to access an existing utility, the driveway shall be replaced using the standards shown below.

##### **4.5.2.2.4.6.1 Concrete Residential Driveway**

Residential driveways shall be replaced with 5-inch, Class A, 3,000 p.s.i. concrete in accordance with current standards for driveways.

##### **4.5.2.2.4.6.2 Concrete Commercial Driveway**

Commercial driveways shall be replaced with 6-inch, Class A, 3,000 p.s.i. concrete in accordance with current standards for driveways.

##### **4.5.2.2.4.6.3 Asphalt Driveway**

Asphalt driveways shall be sawed and replaced in a uniform manner on a compacted base to match existing driveway materials and cross section.

##### **4.5.2.2.4.6.4 Replacement**

All driveways must be replaced with special care taken to satisfy property owners. Driveway removal shall be accomplished by saw cutting at the nearest joint for

concrete driveways, or at ten (10) feet beyond the construction limits or at the right-of-way line, whichever is the shortest distance, for asphalt driveways. Driveways shall be replaced in accordance with standard driveway details used by the City.

### 4.5.2.2.5 Bore Installation

The City will require that installation of utilities under paved roadways be installed using trenchless installation methods unless they meet the requirements of Section 4.5.2.2.4. In cases where the utility service will be provided from existing infrastructure on the opposite side of the roadway, and the utility is located beyond the existing pavement, the installation shall follow the Jack & Bore Detail in Appendix 4B.

In cases where the utility service will be provided from existing infrastructure that is located under existing pavement, the new infrastructure shall be bored to the travel lane under which the utility is located and an open cut in that lane will be allowed in order to make the connection. All applicable components of the Jack & Bore Detail in Appendix 4B will apply. The limits of the open cut for the connection shall be minimized to one (1) travel lane to facilitate traffic flow and to reduce the area required to be reconstructed. Open cuts for utility connections shall follow the Temporary Utility Patch Detail in Appendix 4B.

In cases where the utility service will be provided from existing infrastructure that is located under existing pavement and the utility is located under the nearest travel lane, open cut installation will be allowed. Open cuts for utility connections shall follow the Temporary Utility Patch Detail in Appendix 4B.

Coring should be used to verify the depth and location to ensure the bore can meet the specifications outlined in the City's Standard Drawings (Jack & Bore Detail and Temporary Utility Patch Detail). If the pavement beyond the temporary utility patch is compromised, the City will expect full repair at the developer's expense.

### 4.5.3 Maintenance Process

A smooth riding surface shall be maintained within all patched areas permitted within the travel lanes. Should settlement or compaction of the patching material occur, the permittee shall be required to remove and replace the patch.

## 4.6 STREET LIGHTING

Streetlights shall be provided by the developer of the subdivision. The streetlight should be designed to produce illumination as required by the City and the electrical utility service. The location, density and type of streetlights shall be approved by the City Engineer and/or electrical utility service. For streetlights provided by an electric utility regulated by the Alabama Public Service Commission, the streetlights shall be of the description and the rates set forth in the utility's rate schedules approved by and on file with the Commission.

At a minimum, streetlights shall be located along the streets in the right-of-way at the following locations:

- All street intersections within a subdivision. Streetlights shall be located on all corners of the intersections such that they illuminate the entire intersection,
- Terminal ends of all cul-de-sac streets, and
- Along streets at a minimum interval meeting the requirements of Section 4.6.1.

### 4.6.1 Requirements

Standard spacing of streetlights is as follows:

- Midblock lights are to be located no closer than three hundred (300) feet apart.
- Spacing for poles sixteen (16) or twenty (20) feet in height with decorative fixtures is recommended to be three hundred (300) feet apart.
- Spacing for poles thirty (30) feet in height with cobra head fixtures is recommended to be spaced three hundred (300) to five hundred (500) feet apart.

All lighting plans must be submitted and approved by the City prior to the installation of any conduit or wiring associated with the fixtures.

The cost of the street lighting shall be included in the engineering estimate submitted for the subdivision completion bond.

### 4.6.2 Fixture Types

Generally, there are three (3) alternatives for the selection of lighting fixtures to be installed.

#### 4.6.2.1 Standard Cobra Head Fixtures

The standard lighting assembly provided by the various service providers is a wood pole with an LED cobra head fixture. This light is provided at no cost to the citizen if it can be placed on an existing pole and meets the recommended spacing requirements. When installed in a new subdivision, the developer will be

responsible for costs associated with installation of the lights. The City will incur the energy usage cost for approved lights that meet the City's standard spacing requirements as described in Section 4.6.1. All lighting shall be LED.

### **4.6.2.2 Standard Decorative Fixtures**

This alternative allows the option of a combination of decorative LED lighting assemblies provided by the service provider. The fixtures are installed by the servicing authority and the cost for this installation is the responsibility of the developer. The City will incur the energy usage cost for approved lights that meet the City's standard spacing requirements as per the City streetlight ordinance. The developer must submit lighting plans to the power company and the City for review.

### **4.6.2.3 Specialized Decorative Fixtures**

This alternative allows the developer to select lighting fixtures other than the options provided by the servicing authority. The servicing authority requires that any specialized decorative fixture be comprised of a bulb and photocell that are compatible with the fixtures the service provider currently maintains if the roadway lighting is to be maintained by the servicing authority.

Lighting plans must be submitted and approved by the power company to ensure that the desired fixture is compatible with the standard fixtures for maintenance purposes. Plans shall be stamped and signed by an Electrical Engineer licensed in Alabama and submitted to the City Engineer for approval.

### **4.6.2.4 Decorative Pedestrian Lighting**

To enhance the City's rights of way within the Downtown Redevelopment Plan boundary, decorative pedestrian lighting shall be installed with all new development plans, unless otherwise determined by the City. The lighting shall be designed by an Electrical Engineer licensed in Alabama and be part of the development review and approval process. Photometric requirements shall be subject to the Electrical Engineer's design and the Phenix City's minimum requirements for spacing. Pedestrian lighting is required to be installed prior to issuance of the Certificate of Occupancy.

Guidelines for installation of lighting in the right-of-way are the following:

- Plans shall include preliminary spacing and service point location.
- Building plans shall include full electrical lighting plans signed and stamped by an Electrical Engineer licensed in Alabama. Lighting plans shall be submitted on their own sheet, not on the overall electrical sheets. Lighting sheets shall be reviewed and approved by the City Engineer.

- All power services shall be underground.
- Power services are unmetered services. Receptacles, where required shall have a metered service to be paid by the City of Phenix City. Any service connection fees shall be borne by the Developer.
- Plans need to include:
  - Foundation details for height above grade in both cut and fill scenarios.
  - Recommended placement locations based on edge of pavement or sidewalk location.
  - Minimum wire burial depth of 36" in conduit (not direct bury).
  - Orientation of poles.
  - In some cases, the panel location may be adjusted to accommodate future lighting adjacent to a proposed development.
  - Easement requirements for panels and wire not located within the right-of-way.
  - A note that electrical wiring to be installed in accordance with latest edition of the NEC.
  - A note that power services shall be exclusive for lighting and not facilitated through the building power.
  - Junction boxes or hand holes, when used, shall be rated to a minimum Tier 15.
  - Junction boxes and future conduit extensions to property lines shall be required.
- The contractor is required to call for an inspection from the Engineering and Public Works Department and the Building Department for the following:
  - Prior to pouring concrete foundations
  - All conduit prior to cover
  - All electrical wiring
  - Before permanent power can be supplied
  - A passing final inspection shall be completed prior to issuance of the Certificate of Occupancy and/or release of bonding.
- During installation, if any changes are made to the panel location, wiring or other appurtenances that affect service line size or the overall design,

as-builts are required. The Electrical Engineer must submit a revised design to the City Engineer prior to the issuance of a Certificate of Occupancy.

### 4.7 SIGNING AND PAVEMENT MARKINGS

Signs shall be installed on all City streets as required by the MUTCD, latest edition. Signs required on development sites also must be in accordance with the MUTCD. Plans must include sign locations and notes describing sign sizes, reflectivity, etc., per the MUTCD.

Pavement markings and markers are required on all residential collectors, major and minor collectors and arterials in accordance with the MUTCD, latest edition. Plans must include a striping layout and notes relative to the placement of temporary and permanent striping, markings and pavement markers. Temporary striping must be in place immediately. Asphalt must cure at least two (2) weeks before the placement of permanent markings and pavement markers.

#### 4.7.1 Application Process

##### 4.7.1.1 New Developments

Developers should submit an application for street name signs and regulatory signs for new developments at the earliest possible date. A Traffic Sign Request Form (New Development) can be found in Appendix 4H. The application must be received by the Engineering and Public Works Department, and the name must be approved by the Planning Commission before a development is advertised. The City will not be responsible for problems that result if the development is advertised prior to approval of the development/street name or if the application is rejected.

When a sign request is received, the necessary studies and reviews will be completed to determine whether or not a sign will be approved for installation. If the City Engineer recommends installing the sign, installation of the sign will be approved. If it is determined that the sign shall not be installed, a representative of the Engineering and Public Works Department will notify the applicant.

All signs approved for installation shall be installed at the approved locations by the Developer for final inspection by the City Engineer or Public Works Department.

##### 4.7.1.2 Existing Developments

Requests for new signs or replacement of existing street name or regulatory signs on public right-of-way in developments accepted for maintenance by the City shall be coordinated with the City Engineer and Public Works Department. A



Traffic Sign Request Form (Existing Development) can be found in Appendix 4I. When a sign request is received, the necessary studies and reviews will be completed to determine whether or not a sign will be approved for installation. If the City Engineer recommends installing the sign, the approved sign shall be installed by the Engineering and Public Works Department or under the Department's supervision. The City Engineer will establish the location of approved signs. If it is determined that the sign shall not be installed or replaced, a representative of the Engineering and Public Works Department will notify the Applicant.

### 4.7.2 Requirements

#### 4.7.2.1 Street Name Signs

Street name markers shall be placed at the corners of all street intersections within the corporate limits and the planning jurisdiction of the City. Said markers shall be of a standard design in current use within the City and placed at locations the City Engineer or another duly authorized agent of the City may direct.

Many developers request the use of decorative signs and posts that are unique to their subdivision. Developers may elect to use their own standard sign provided it meets the following criteria set by the City.

- The City Engineer must approve the sign and signpost.
- The background and lettering must be retroreflective.
- The sign must be mounted on a breakaway post in accordance with the MUTCD, latest edition.
- The sign shall have a dark background with white lettering (all reflective).
- The sign shall meet minimum letter size requirements established by the MUTCD, latest edition.
- The lettering font must be similar to a block style.
- The sign must be installed at a location identified by the MUTCD, latest edition. The City Engineer will be available for consultation prior to sign installation if necessary.
- Special insignia for the subdivision may be used if approved by the City Engineer; however, the special insignia will not be maintained or replaced by the City.

#### 4.7.2.2 Regulatory Signs

Regulatory signs are traffic signs intended to instruct road users on what they

must or should do (or not do) under a given set of circumstances. The term regulatory sign describes a range of signs that are used to indicate or reinforce traffic laws, regulations or requirements which apply either at all times or at specified times or places upon a street or highway, the disregard of which may constitute a violation. These criteria are set out in the MUTCD, which specifies conditions for the installation as well as requirements for maintenance.

Developers may elect to use their own standard sign provided it meets the following criteria set by the City:

- The City Engineer must approve the sign and signpost.
- The sign must be mounted on a breakaway post in accordance with the MUTCD, latest edition.
- The sign must meet minimum requirements established by the MUTCD, latest edition, including size and color.
- The sign shall be fabricated from high intensity prismatic material that satisfies the requirements set forth in the MUTCD.
- The sign must be installed at a location identified by the MUTCD, latest edition. The City Engineer will be available for consultation prior to sign installation if necessary.

### **4.7.3 Maintenance Process**

#### **4.7.3.1 Replacement for Street Name or Regulatory Signs**

Once the City has accepted maintenance of a roadway, the City will be responsible for replacement of street name or regulatory signs or signposts that are damaged. Prior to acceptance by the City, the developer is responsible for replacement of damaged signs.

#### **4.7.3.2 Replacement for Decorative Signs**

The City will not be responsible for replacement of decorative signs and signposts. If a decorative sign or signpost is damaged, the developer/owner or Neighborhood or Homeowners' Association is responsible for replacing and or repairing the sign in a timely manner. If the sign has not been repaired or replaced within seven (7) days, the City will install a temporary replacement sign until a new sign is obtained. Upon installation of the new decorative sign, the temporary signs and signposts must be returned to the City. If sign is not returned, the City will bill the developer or Neighborhood or Homeowners' Association for the cost of the temporary sign.

If a decorative stop sign is damaged, the City will install a regulatory stop sign immediately for safety.

### 4.8 RIGHT-OF-WAY PLANTING

On Phenix City-owned streets, trees located in the right-of-way are property of the City of Phenix City. The removal of right-of-way trees is prohibited without written permission from the City Council. Applicant shall request removal of right-of-way trees on submitted landscape plan, showing said right-of-way trees. Any trees removed from the right of way shall not be sold for pulp wood, lumber, firewood or any other purpose.

If any tree or trees are damaged or removed without permission from the City of Phenix City, they shall be replaced at the owner's expense with trees of similar type and size. If a large caliper tree is removed, multiple smaller trees may be required to replace the number of caliper inches lost. Property owner shall prepare a landscape plan that shows damaged or removed trees, and shall indicate graphically the proposed replacement plantings, including species, quantity, size and location. This tree replacement plan shall be presented to the Phenix City Planning Commission and/or City Council for approval. Right-of-way trees located on State Routes shall not be removed without permission from ALDOT and the City of Phenix City.

All proposed plantings within the right-of-way must be approved by the Phenix City Planning Commission and/or City Council prior to installation. Trees placed within the public right-of-way shall not be of a low, bushy species that might obstruct sight distance. No such trees shall be planted unless approved by the City Engineer, who shall determine whether they pose a threat to public safety or the efficient use of public facilities. Trees shall not be placed in any location where they may damage or impede access to buried utility lines, sidewalks or streets. Trees shall not be planted within water or sanitary sewer utility easements. Canopy trees shall be placed such that the mature drip line is not within ten (10) feet of water or sanitary sewer lines.

New trees installed within the right-of-way as part of a development shall be installed per the City's Zoning Ordinance. Tree locations and species shall be coordinated with City staff during the design review process.

#### 4.8.1 Application Process

A Landscape Plan shall be submitted at the time of application for building permits with other construction plans. The following criteria shall apply.

- Landscape Plans shall be submitted on a separate drawing sheet(s) of a standard size (preferably 22" x 34" to be easily printed as a half-size) and drawn to a standard scale (preferably engineer's scale). Included on all sheets shall be project name, address, scale, date of plan, and north arrow.
- Landscape Plans shall show proposed plant material names (botanical and common), quantity, size, spacing, and any special planting notes.
- Landscape Plans shall locate any and all existing or proposed structures, roads, paved areas, utilities, property lines, etc.

- Landscape Plans shall illustrate and table Street Frontage Buffer Requirements, Side and Rear Buffer Requirements, and Parking Lot Requirements set forth by the Ordinance.
- Landscape Plans will indicate type, size and locations of existing trees to be preserved as "Tree Protection Area" and shall clearly detail type of protection, such as fencing and signs. Trees shall not be planted within the clear zone or the sight triangle of a public street.
- Plant material and installation must meet standards published by the American Society of Nurserymen in "American Standard for Nursery Stock", ANSI Z60.1-2004 (latest edition).
- Landscape plans shall be drawn by an architect, landscape architect, engineer, or landscaper licensed by the State of Alabama.

### 4.8.2 Design Criteria

#### 4.8.2.1 Visibility at Intersections

To provide a clear view at intersections, there shall be an unobstructed triangular area at the junction of any two streets. The size of this triangular area is a function of the classification of the streets, which in turn is a function of the relative volume and speed of traffic on them.

For streets that intersect at an oblique angle, the triangular areas of clear vision for the intersection shall meet the standards contained in the latest edition of the AASHTO Green Book and the requirements of Section 4.3.1.3 Sight Distance.

Where a driveway intersects with a public street, an unobstructed triangular area measuring ten (10) feet from the intersection along the right-of-way and ten (10) feet from the intersection along the edge of the driveway shall be provided.

Within the triangular areas defined above, nothing shall be planted, placed, erected, or allowed to grow that will interfere with visibility between a height of two and one half (2.5) feet and fifteen (15) feet above grade at the intersection of the two street center lines or the right-of-way and driveway edge.

At signalized intersections or at intersections with all-way stop control, the first stopped vehicle on one approach shall be visible to the stopped drivers at each of the other approaches.

#### 4.8.2.2 Right-of-Way Trees

Existing trees located within the right-of-way either causing upheaval of sidewalk sections or otherwise compromised by sidewalk installation, repair or

replacement shall be evaluated by the City Engineer who shall make a recommendation as to the health and life expectancy of said trees. Existing trees within the right-of-way that are determined to be unhealthy and/or near term shall be removed by the City, at no expense to the property owner.

### 4.8.2.3 Irrigation

Private irrigation systems shall be prohibited within the public right-of-way.

All irrigation installed within the public right-of-way shall only be permitted through a right-of-way encroachment agreement with the City of Phenix City. Irrigation systems placed on City right-of-way are placed at the risk of the property owner. Phenix City reserves the right to remove the system with notice to the owners without compensation or replacement. The City shall not restore or pay any restoration or replacement costs for any reason.

No major irrigation equipment shall be located within the right-of-way. Lateral lines, emitter and distribution tubing may be located within the right-of-way but should be as close to the property line as possible.

Heads and pipe types shall be of a common type such that replacement is easily accommodated.

### 4.8.3 Maintenance Process

All planted areas within the right-of-way shall be maintained in a satisfactory condition until the work has been completed, and the City has accepted maintenance. Care shall consist of providing protection of the planting beds and seedling areas, and weeding and/or repairing all planted areas or pits, including an area three (3) feet outside of the normal perimeter of the beds, pits or bedding areas.

## 4.9 ACCESS MANAGEMENT AND COORDINATION

Access management balances the need to provide mobility for traffic and accessibility to property. The purpose of this section is to establish minimum regulations for access to property. Standards are established for new roads, driveways, shared access, parking lot cross access, and service roads throughout the City. When access management standards are implemented there are many potential benefits.

- Promote safe and efficient travel within the City
- Minimize disruptive and potentially hazardous traffic conflicts
- Ensure safe access by emergency vehicles
- Protect the public investment in the street system by preserving capacity and avoiding the need for unnecessary and costly reconstruction

- Separate traffic conflict areas by reducing the number of driveways
- Provide safe spacing standards between driveways and between driveways and intersections
- Provide for shared access between abutting properties
- Ensure reasonable access to properties (not necessarily the most direct access)
- Coordinate access decisions with the Planning Commission and City Council

The access management standards in this Manual shall be applied in addition to the requirements of the Zoning Ordinance and the Subdivision Regulations.

### 4.9.1 Application Process

ALDOT is responsible for access permits along State and Federal routes. These permits include turnout permits, permits for median crossovers and permits for installation of traffic signals. The City oversees land use, subdivision, and site design decisions that affect access needs. State and local coordination is essential to effective access management. Lack of coordination can undermine the effectiveness of regulatory programs and cause unnecessary frustration for permit applicants.

Timely communications are essential to an effective review procedure, and it begins with a coordinated process for review of access permits along State routes. Applicants should send completed permit applications for access to State controlled roadways to the appropriate ALDOT office with copies being transmitted to the City Engineer. This shall occur early in the plat review process, preferably during conceptual review. Prior to any decision or recommendation concerning permitting of access, the local reviewing official and the State permitting official should discuss the application.

Property owners will be required to submit the necessary certificates of approval from other affected regulatory agencies before Phenix City will issue a Building Permit. An effective method of coordinating review and approval between developers and various government agencies is through a tiered process. The first stage is an informal meeting and “concept review” period involving State and Phenix City representatives, which allows officials to advise the developer about information needed to process a development application. This includes information on required State and local permits, and any special considerations for the development site. The concept review provides the developer with early feedback on a proposal, before the Preliminary Plat or site plan has been drafted. Once the preliminary plan is drafted, it can be checked to determine if additional conditions are required for approval. The final plan that is formally submitted should then require only an administrative review.

### 4.9.2 Design Criteria

A traffic impact study shall be prepared and sealed by an engineer licensed in Alabama who has expertise in traffic impact studies and transportation planning. See Section 3.0 for the Traffic Impact Study Requirements.

A traffic signal may only be permitted when at least one traffic safety warrant is satisfied, and other reasonable alternatives have been considered. See Section 2.0 for the Traffic Signal Design Guidelines.

### 4.10 OFF-STREET PARKING

Off-street parking lots may be designed in many differing configurations. Figure 4.14 illustrates some of the most common elements in designing a parking lot. Each parking space shall consist of an adequate space for parking an automobile with room for opening doors on both sides of the vehicle. In addition, there shall no cases of the parking space being less than nine feet wide x eighteen feet long (9' x 18'). Parking aisles shall be designed with maneuvering room for proper access for the vehicle through the site. Any parking lot that incorporates the elements from Figure 4.14 shall conform to the minimum dimensional requirements for each configuration.

Figure 4.14 Parking Diagram

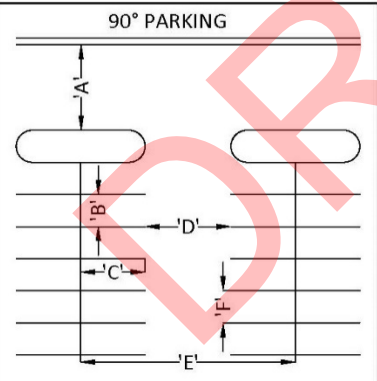
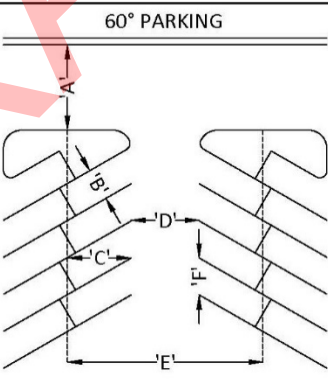
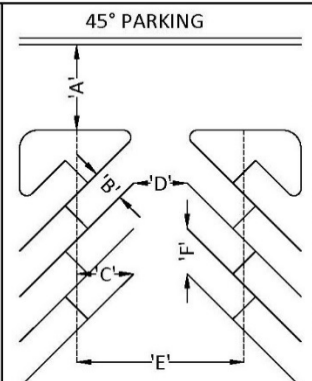
PARKING TYPE	90° PARKING	60° PARKING	45° PARKING
DIAGRAM			
DIMENSIONS			
'A'	24'	24'	24'
'B'	9'	9'	9'
'C'	18'	17.84'	15.91'
'D'	24'	19'	15'
'E'	60'	54.67'	46.82'
'F'	9'	10.39'	12.73'

Every parking space shall be clearly delineated. Provisions should be made so that parked vehicles shall not overhang or extend over sidewalk areas. In addition, all parking lots shall meet the ADA requirements for accessible parking. Please refer to the Department of Justice manual "2010 ADA Standards of Accessible Design" for these requirements.

For location and minimum number of parking spaces, please refer to Article VIII of the Phenix City's Zoning Ordinance.

### **4.11 TRAFFIC CALMING (NEW DEVELOPMENTS ONLY)**

Traffic calming is a means in which to reduce speeds and minimize vehicular traffic on local neighborhood streets. Citizen involvement in neighborhood traffic management activities is strongly encouraged. This section is intended to aid citizens in resolving traffic problems in residential areas.

In the City, traffic calming techniques are limited to local residential streets. A *local residential street* is defined as all minor streets, marginal access streets and cul-de-sacs primarily serving residential property.

Traffic calming measures shall conform to engineering and procedural standards established by the Manual of Uniform Traffic Control Devices, Institute of Transportation Engineers and the City Engineer or designee.

During the planning process, local subdivision streets shall be laid out to reduce the likelihood of cut through traffic from Collector and Arterial roadways. Long tangent sections, which would encourage higher than posted speeds, will not be permitted.

Through traffic should be encouraged to use higher classification streets (i.e. arterial and collector streets).

In areas where speeding is determined to be a problem, traffic calming measures shall be implemented to reduce speeds.

The following procedures are considered typical for receiving, responding to, and managing citizens' requests for residential traffic management on their streets or in their neighborhoods. Variations in this process may be approved by the City Council when deemed appropriate.

#### **4.11.1 Existing Condition Analysis**

The existing conditions will be analyzed through a transportation study. Transportation study requests will be accepted on a rolling basis and will be performed considering the order in which they are received and the potential severity of the transportation concern. The City Engineer reserves the right to expand the study area due to potential adverse impacts to areas adjacent to the original request.

The Engineering and Public Works Department will perform any necessary data collection and analysis to assess and quantify the traffic and safety conditions in the neighborhood.



The Engineering and Public Works Department staff will identify the tentative study area, collect preliminary information from their files and other potentially affected agencies, and complete any needed traffic analysis. While there are no absolute minimum criteria or warrants established for use of traffic calming techniques, staff will refer to the following guidelines when evaluating the magnitude of traffic and safety problems, potential for improvement using traffic calming techniques, and establishment of priorities for project implementation.

**4.11.1.1 Minimum Vehicular Volume**

Traffic volumes on residential streets will determine the appropriate traffic calming measures as follows:

- Less than four thousand (4,000) vehicles per day: Education; Enforcement; Increased police enforcement for traffic violations (i.e. speeding); and Physical techniques;
- More than four thousand (4,000) vehicles per day: Education; Enforcement; Increased police enforcement for traffic violations (i.e. speeding); Alternative actions only - no physical techniques.

**4.11.1.2 Speed**

The ideal, acceptable and not acceptable traffic speeds on local streets are as follows:

**TABLE 4.13 Vehicle Speeds on Local Streets**

	<b>Ideal</b>	<b>Acceptable</b>	<b>Not Acceptable</b>
Average Speed – All Vehicles	0-25 mph	26-30 mph	31-35 mph
85 <sup>th</sup> Percentile Speed	0-30 mph	31-35 mph	36-40 mph
95 <sup>th</sup> Percentile Speed	0-35 mph	36-40 mph	41-45 mph
Percent of Vehicles in 10 mph Pace Speed	70%	60%	50%

**4.11.1.3 Cut Through Traffic**

A vehicle that detours through a neighborhood for the convenience of decreasing the amount of time it takes to reach a destination is known as cut through traffic. The volume of cut through traffic is typically quantified by estimating the expected traffic generated by a neighborhood based on the Institute of Transportation Engineers (ITE) *Trip Generation* Land Use 210 – Single Family Housing. The expected daily volume is divided by the actual daily traffic volume to calculate the percent of cut through traffic.

The acceptable and not acceptable percentages of cut through traffic are as shown in Table 4.14.

**TABLE 4.14 Cut Through Traffic**

Classification	Acceptable	Not Acceptable
Local Street	0% - 24%	≥ 25%
Collector Street	0% - 49%	≥ 50%

**4.11.1.4 Crashes**

Crash problems are considered significant when there are three (3) or more reported crashes, including pedestrian, bicycle and auto crashes, along a residential street or within a neighborhood during a period of twelve (12) consecutive months.

**4.11.1.5 Street Grades and Alignment**

Traffic calming techniques are not typically installed on streets with grades exceeding eight (8%) percent, or where a combination of vertical and horizontal alignment would result in inadequate stopping sight distance for motorists encountering traffic calming measures.

**4.11.1.6 Transit, School, and Emergency Routes**

Traffic calming techniques are not typically installed on streets serving as designated transit routes or primary emergency access routes. School authorities should be consulted in conjunction with proposed traffic calming techniques if a school route is considered.

**4.11.2 Results of Traffic Calming Analysis**

The various data collected in the field reconnaissance and during the data collection effort will be summarized and analyzed to determine if a problem does or does not exist. Once the nature and degree of the traffic problem(s) is fully assessed, the City Engineer (in conjunction with fire, police, and public works officials), will formulate a series of alternative improvement concepts. Any traffic control measure that has been found to be effective and is accepted by recognized governmental and professional agencies will be evaluated for potential application.

Formulation of improvement strategies will consider the following guiding principles:

- Changes that compromise public safety or significantly impact emergency vehicle access will not be employed.

- The capital and maintenance costs of improvements will receive appropriate consideration.
- Use of official traffic control devices shall conform in design and application to standards contained in the Manual of Uniform Traffic Control Devices (MUTCD).
- Preference shall be given to those management techniques that will achieve the desired improvement and cause the least negative impact on the neighborhood.
- The final location of traffic calming installations shall be determined by the City Engineer or designee.

Table 4.15 is a listing of speed requirements and recommended devices that could be used to address speeding. These devices are in order from less intrusive to more intrusive. No traffic calming device will be recommended for any collector or arterial or any street with a traffic volume of over 4000 vehicles per day.

**TABLE 4.15 Recommended Traffic Calming Techniques**

85 <sup>th</sup> Percentile Speed Above Posted Speed Limit	Traffic Calming Device Recommended
0-10 mph	No Device Recommended
11-20 mph	Street Narrowing or Surface Roughening
21 mph and above	Combination of Devices

**4.11.3 Neighborhood Petitions and Cost Share**

Traffic calming measures will be implemented based on desired results. There are 3 stages of intervention that can be used in traffic calming:

- Stage 1: Education, enforcement, signage, striping
- Stage 2: Mini traffic circles, chicanes, pinch points/chokers, intersection narrowing, center island narrowing (Descriptions of traffic calming measures are included in Appendix 4J.)
- Stage 3: Roadway closures, signals

When a traffic problem can be addressed using Stage 1 tools, the City will notify the Neighborhood or Homeowners’ Association and petition originator via letter. No further action is required for the City to go ahead with the project.

If criteria are met for Stage 2 or 3 traffic calming measures to be considered, a neighborhood petition from the “study area” is required. The “study area” is defined as

those properties along streets that could potentially receive traffic calming measures, those streets whose access is substantially dependent upon the streets to be calmed, and any streets expected to receive significant increases in traffic volume or type as a result of the implementation of traffic calming measures.

It is the responsibility of the Applicant to submit a proposed "study area" and petition to the City Engineer for review and approval. When a proposed technique is approved, the City Engineer will prepare a petition package to be circulated by the Applicant. A standard petition package can be found in Appendix 4K. The petition will include the name and address of each of the property owners in the affected area as well as the description and detail of the proposed technique. The Applicant can pick up the petition package or arrange to have it mailed.

It is the responsibility of the Applicant to circulate the petition within the affected area. The petition must be delivered (in a legally accepted manner) or offered to all property owners in the affected area. A positive response must be obtained by sixty-six (66%) percent or more of the total number of properties in the affected area to proceed further with the traffic calming project design and implementation. The petition must be returned to the City Engineer within three (3) months of receipt of the petition package by Applicant. At the request of the City Engineer, the City will circulate the petition in the form of mail-out postcards. A positive response of sixty-six (66%) percent or more must still be achieved. Those properties that do not submit a response after three (3) attempts by the City will be counted as a negative response.

The installation cost of calming techniques may be shared with the City and the neighborhood requesting the technique. If the City's standard materials are used, there will be no cost to the neighborhood. If decorative or non-standard measures are desired, the neighborhood will incur the additional cost for the specialty items.

### **4.11.4 Implementation**

When a traffic calming project has received the necessary approvals, the City Engineer will schedule design and implementation of the project within budgetary constraints. All designs shall follow ITE or other nationally recommended guidelines, if available. Depending upon the number of traffic calming requests received, a project may be placed on a waiting list and prioritized based on relative need. Certain techniques may be installed for a "test period" while others may be installed in a permanent fashion.

#### **4.11.4.1 Material Submittal**

The standard technique will be a City mountable curb surrounding a planted island. Yellow three (3) button delineators will be installed for visibility around the outer perimeter on City standard green U-channel posts.

A standard island may contain drought tolerant landscaping or hardscape. A tree may be positioned in the center as necessary for visibility concerns, of appropriate size and type to conform with clear zone requirements and if approved by the City Engineer. Vegetation will be installed as designated by the City Engineer. A water spigot may be included as standard landscaping for maintenance of vegetation. Any necessary property dedication or landscape maintenance agreement shall be completed prior to final project design.

Should a Neighborhood or Homeowners' Association prefer a more decorative final product, a request of the design preferences shall be made to the City Engineer. The request will be reviewed by the City Engineer for safety and maintenance issues. If approved, the Neighborhood or Homeowners' Association shall be responsible for any additional costs incurred for all decorative elements. An agreement must be signed between the City and representatives of the Neighborhood or Homeowners' Association and approved by the City Council. This agreement may also include a maintenance element, if the Neighborhood or Homeowners' Association elects to maintain the landscaping.

#### **4.11.4.2 Test Requirements**

The Neighborhood or Homeowners' Association will be responsible for the costs incurred for all testing services required for non-standard, decorative elements.

#### **4.11.4.3 Inspection**

The Neighborhood or Homeowners' Association will be responsible for the costs incurred for all inspection services required for non-standard, decorative elements.

#### **4.11.5 Maintenance**

Maintenance of traffic calming techniques will be the responsibility of the City, unless a Neighborhood or Homeowners' Association has a written agreement with the City to maintain the area.

#### **4.11.6 Review and Analysis of Applied Solutions**

The City will perform a review to evaluate the effectiveness of the applied technique after the residents and motorists have had adequate time to adjust to the change. The evaluation will be completed within six (6) months to a year following construction of the traffic calming measure(s). The evaluation will include resident and motorist reaction, field observation, traffic counts, speed studies, and other data collection as needed. The city reserves the right to remove any traffic calming measure that is potentially unsafe and impairs the public safety and welfare.

## **4.12 CONSTRUCTION**

Construction plans along with all necessary design calculations, a wetland assessment, an erosion and sediment control Best Management Practices (BMP) Plan prepared by a Qualified Credentialed Professional (QCP), required permits and clearances shall be submitted for review and approval as required by the Phenix City Subdivision Regulations. Approval of the plans by the City signifies that the plans meet the minimum requirements of the Subdivision Regulations.

Refer to Sections 1.3.2.3 and 8.0 for further requirements during construction.

DRAFT

### **References**

*A Policy on Geometric Design of Highways and Streets, 7th Edition*, American Association of State Highway and Transportation Officials (2018) (AASHTO Green Book)

*Guide for the Development of Bicycle Facilities*, American Association of State Highway and Transportation Officials (2012)

*Roadside Design Guide, 4<sup>th</sup> Edition*, American Association of State Highway and Transportation Officials (2011)

*Manual on Uniform Traffic Control Devices*, U.S. Department of Transportation, Federal Highway Administration (2009)

*Publication No. FHWA-RD-00-067 Roundabouts: An Informational Guide*, Federal Highway Administration (2000)

*Report 279 Intersection Channelization Design Guide*, National Cooperative Highway Research Program (NCHRP) (1985)

*Report 457 Evaluating Intersection Improvements: An Engineering Study Guide*, National Cooperative Highway Research Program (NCHRP) (2001)

*International Fire Code (IFC)*, International Code Council (2018)

*2010 ADA Standards for Accessible Design*, U.S. Department of Justice (2010)

*Public Right-of-Way Accessibility Guidelines (PROWAG)*, United States Access Board (2011)

*Trip Generation Manual, Current Edition*, Institute of Transportation Engineers (ITE)

*2017 National Electrical Safety Code (NESC)*, Institute of Electrical and Electronics Engineers (IEEE)

*American Standard for Nursery Stock (ANSI Z60.1)*, American Horticulture Industry Association (AmericanHort) (2014)

*ALDOT Access Management Manual* (2014)

*ALDOT Construction Manual* (2000 including updates through 2020)

*ALDOT Guidelines for Operation* (2020 Revisions)

*ALDOT Special and Standard Highway Drawings* (2021)

*ALDOT Standard Specifications for Highway Construction* (2018)

*Phenix City's Comprehensive Community Master Plan* (December 2014)

*Downtown Phenix City Redevelopment Plan*

*Phenix City's Subdivision Regulations* (Amended and Approved April 12, 2016)

*Phenix City's Zoning Ordinance* (Amended July 15, 2014)

DRAFT



**APPENDIX 4A**  
**STREET CLASSIFICATIONS**

DRAFT

DRAFT

**Street Classifications**

**Arterial Roads** - Arterials carry large volumes of traffic. They connect principal urbanized areas or activity centers, schools and industrial centers. The Phenix City Express (PEX) operates fixed routes along some of the arterials.

**Collector Roads** - Collectors connect local roads and streets with arterials while balancing mobility with land access.

**Local Commercial/ Local Streets/ Cul-De-Sacs/ Alleys** - Local roads provide access to residential areas, businesses, farms and other local areas.

No.	Street	From	To	Classification
1	10TH Avenue	Idle Hour Drive	31ST Street	Local
2	10TH Avenue	26TH Street	25TH Street	Local
3	10TH Avenue	31ST Street	29TH Street	Local
4	10TH Avenue	13TH Street	Dillingham Street to End	Local
5	10TH Avenue	South Railroad Street	13TH Street	Local
6	10TH Avenue	20TH Street	North Railroad Street	Local
7	10TH Avenue S	Seale Road	Fontaine Road	Major Collector
8	10TH Court	34TH Street	11TH Avenue	Local
9	10TH Court	15TH Street	13TH Place	Local
10	10TH Court	16TH Street	15TH Place	Local
11	10TH Court	20TH Street	North Railroad Street	Local
12	10TH Court	22ND Street	23RD Street	Local
13	10TH Court S	4TH Place S	5TH Street S	Local
14	10TH Court S	6TH Street S	6TH Place S	Local
15	10TH Place	17TH Avenue	18TH Avenue	Local
16	10TH Place	Broad Street	West to End	Local
17	10TH Street	16TH Avenue	16TH Court	Local
18	10TH Street	15TH Avenue	14TH Court	Local
19	10TH Street	17TH Avenue	18TH Avenue	Local
20	10TH Street	25TH Avenue	HWY 280/431	Local
21	11TH Avenue	32ND Street	Idle Hour Drive	Local
22	11TH Avenue	Sandfort Road	North to End	Local
23	11TH Avenue	12TH Street	9TH Street	Local
24	11TH Avenue	14TH Street	12TH Place	Local
25	11TH Avenue	South Railroad Street	16TH Street	Local
26	11TH Avenue	16TH Street	14TH Street	Local
27	11TH Avenue	20TH Street	North Railroad Street	Local

## 4.0 ROADWAY AND PARKING DESIGN

No.	Street	From	To	Classification
28	11TH Avenue	21ST Street	23RD Street	Local
29	11TH Avenue	Seale Road	Knowles Road	Local
30	11TH Avenue S	4TH Place S	5TH Place S to End	Local
31	11TH Avenue S	1ST Street	3RD Place S	Local
32	11TH Court	Dillingham Street	9TH Street	Local
33	11TH Court	21ST Street	North Railroad Street	Local
34	11TH Court	27TH Street	26TH Street	Local
35	11TH Court S	End past 1ST Place South	2ND Place S	Local
36	11TH Place	28TH Street	End	Local
37	11TH Place S	20TH Avenue S	16TH Court S	Local
38	11TH Street	10TH Avenue	12TH Avenue	Local
39	11TH Street	14TH Avenue	16TH Avenue to End	Local
40	11TH Street	Broad Street	East to End	Local
41	11TH Street	Ingersoll Drive	HWY 280/431 North	Local
42	11TH Street	28TH Avenue	West to End	Local
43	12TH Avenue	36TH Street	32ND Street	Local
44	12TH Avenue	Summerville Road, west side	28TH Street	Local
45	12TH Avenue	13TH Street	12TH Court	Local
46	12TH Avenue	8TH Street	Sandfort Road	Local
47	12TH Avenue	9TH Street	8TH Street	Local
48	12TH Avenue	11TH Street	9TH Street	Local
49	12TH Avenue	16TH Street	14TH Street	Local
50	12TH Avenue	20TH Street	22ND Street	Local
51	12TH Avenue	Knowles Road	North to End	Local
52	12TH Avenue	End	2ND Street	Local
53	12TH Avenue S	3RD Place S	4TH Place S	Local
54	12TH Avenue S	3RD Street S	South to End	Local
55	12TH Avenue South	4TH Place South	5TH Street South	Local
56	12TH Court	12TH Avenue	12TH Street	Local
57	12TH Court	8TH Street	Sandfort Road	Local
58	12TH Court	17TH Street	15TH Place	Local
59	12TH Court	17TH Street	North to End	Local
60	12TH Place	12TH Street	HWY 280 Access Lane	Local
61	12TH Place	10TH Avenue	11TH Avenue	Local
62	12TH Place	11TH Avenue	12TH Avenue	Local
63	12TH Place	12TH Court	14TH Avenue	Local
64	12TH Place	8TH Avenue	9TH Avenue	Local

#### 4.0 ROADWAY AND PARKING DESIGN

No.	Street	From	To	Classification
65	12TH Place	14TH Avenue	16TH Avenue	Local
66	12TH Place	16TH Avenue	Ingersoll Drive	Local
67	12TH Place S	20TH Avenue S	16TH Court S	Local
68	12TH Street	28TH Avenue	End	Local
69	12TH Street	10TH Avenue	West to End	Local
70	12TH Street	12TH Avenue	16TH Avenue	Local
71	12TH Street	Abbot Drive	West to End	Local
72	12TH Street	16TH Avenue	18TH Avenue	Local
73	12TH Street	Broad Street	10TH Avenue	Local
74	12TH Street	HWY 280/431 North	West to End	Local
75	12TH Street	Broad Street	East to End	Local
76	12TH Street S	S Seale Road	Loops to University Place	Local
77	13TH Avenue	29TH Street	28TH Street	Local
78	13TH Avenue	36TH Street	32ND Street	Local
79	13TH Avenue	43RD Street	Airport Road	Local
80	13TH Avenue	12TH Avenue	8TH Street	Local
81	13TH Avenue	13TH Place	12TH Street	Local
82	13TH Avenue	14TH Court	22ND Street	Local
83	13TH Avenue	South Railroad Street	15TH Place	Local
84	13TH Avenue	21ST Street	North Railroad Street	Local
85	13TH Avenue	Knowles Road	3RD Place	Local
86	13TH Avenue	28TH Street	27TH Street	Local
87	13TH Avenue N	3RD Place	End	Local
88	13TH Avenue S	1ST Place	2ND Street S	Local
89	13TH Avenue S	7TH Street S	9TH Place S	Local
90	13TH Court	13TH Avenue	8TH Street	Local
91	13TH Place	12TH Court	17TH Avenue	Local
92	13TH Place	17TH Avenue	Ingersoll Drive	Local
93	13TH Place	23RD Court	25TH Avenue	Local
94	13TH Place	12TH Court	13TH Avenue	Local
95	13TH Place (Flynn Alley)	11TH Avenue	End	Local
96	13TH Street	17TH Avenue	19TH Avenue to End	Local
97	13TH Street	24TH Avenue	HWY 280/431 North	Local
98	13TH Street	28TH Avenue	HWY 280	Local
99	13TH Street (AKA Pine Loop)	17TH Avenue	17TH Avenue	Local
100	14TH Avenue	33RD Street	30TH Street	Local
101	14TH Avenue	46TH Street	14TH CT	Local

## 4.0 ROADWAY AND PARKING DESIGN

No.	Street	From	To	Classification
102	14TH Avenue	End From 12TH Place	9TH Place	Local
103	14TH Avenue	South Railroad Street	Crawford Road	Local
104	14TH Avenue	14TH Street	South to End	Local
105	14TH Avenue	N Railroad Street	21ST Street	Local
106	14TH Avenue	Knowles Road	End	Local
107	14TH Avenue	Martin Luther King Jr. Parkway	Sandfort Road	Local
108	14TH Avenue N	1ST Place	2ND Street S	Local
109	14TH Avenue S	7TH Street S	9TH Street S	Local
110	14TH Avenue S	2ND Street S	3RD Street S	Local
111	14TH Avenue S	Lockhart Circle	Jackson Drive	Local
112	14TH Court	46TH Street	14TH Avenue	Local
113	14TH Court	28TH Street	15TH Avenue	Local
114	14TH Court	11TH Street	10TH Street	Local
115	14TH Court	12TH Place	11TH Street	Local
116	14TH Court	South Railroad Street	Crawford Road	Local
117	14TH Court	21ST Street	22ND Street	Local
118	14TH Court	1ST Place	2ND Street	Local
119	14TH Court N	2ND Street	1ST Place	Local
120	14TH Court S	3RD Street S	to End	Local
121	14TH Place	10TH Court	11TH Avenue	Local
122	14TH Place	12TH Avenue	14TH Avenue	Local
123	14TH Street	Broad Street	Crawford Road	Minor Arterial
124	14TH Street	5TH Avenue	Broad Street	Minor Arterial
125	14TH Street	5TH Avenue	Whitewater Avenue.	Minor Arterial
126	14TH Street	24TH Avenue	East to End	Local
127	14TH Street	24TH Avenue	25TH Avenue to End	Local
128	14TH Street	20TH Avenue	Cul-de-sac	Local
129	14TH Street	34TH Avenue	Wright Road	Local
130	15TH Avenue	45TH Street	North to End	Local
131	15TH Avenue	29TH Street	28TH Place	Local
132	15TH Avenue	9TH Place	9TH Street	Local
133	15TH Avenue	12TH Street	10TH Street	Local
134	15TH Avenue	8TH Street	End	Local
135	15TH Avenue	22ND Street.	24TH Street	Local
136	15TH Avenue	28TH Place	28TH Street	Local
137	15TH Avenue N	South Railroad Street	Crawford Road	Local
138	15TH Avenue S	1ST Place	5TH Street S	Local

## 4.0 ROADWAY AND PARKING DESIGN

No.	Street	From	To	Classification
139	15TH Avenue S	7TH Street S	8TH Street S	Local
140	15TH Court	24TH Street	End	Local
141	15TH Place	10TH Avenue	14TH Avenue	Local
142	15TH Place	9TH Avenue	10TH Avenue	Local
143	15TH Street	11TH Avenue	East to End	Local
144	15TH Street	11TH Avenue	12TH Avenue	Local
145	15TH Street	12TH Avenue	14TH Avenue	Local
146	15TH Street	7TH Avenue	8TH Avenue	Local
147	15TH Street	9TH Avenue	West to End	Local
148	15TH Street	7TH AVE	8TH Avenue	Local
149	15TH Street	3RD Avenue	5TH Avenue	Local
150	15TH Street	14TH Avenue	18TH Avenue	Local
151	16TH Avenue	45TH Street	Nottingham Drive	Local
152	16TH Avenue	40TH Street	North to End	Local
153	16TH Avenue	43RD Street	North to End	Local
154	16TH Avenue	40TH Street	39TH Street	Local
155	16TH Avenue	45TH Street	End	Local
156	16TH Avenue	HWY 280/431 North	7TH Street	Local
157	16TH Avenue	13TH Place	HWY 280/431North	Local
158	16TH Avenue	24TH Street	26TH Street	Local
159	16TH Avenue	South Railroad Street	15TH Street	Local
160	16TH Avenue	21ST Street	Dead End	Local
161	16th Avenue	28TH Place	26TH Street	Local
162	16TH Avenue N	Sandfort Road	End	Local
163	16TH Avenue S	Knowles Road	5TH Street S	Local
164	16TH Avenue S	7TH Street S	Cul-de-sac	Local
165	16TH Avenue/ Ingersol Court.	Crawford Road	HWY 280/431 North	Major Collector
166	16TH Court	47TH Street	48TH Street	Local
167	16TH Court	Melanie Lane	Fletcher Drive	Local
168	16TH Court	10TH Street	North to End	Local
169	16TH Court	12TH Street	North to End	Local
170	16TH Court	26TH Street	24TH Street	Local
171	16TH Court	10TH Street	South to End	Local
172	16TH Court S	Seale Road	12TH Place S	Local
173	16TH Place	Opelika Road	26TH Avenue	Local
174	16TH Place	18TH Court	20TH Avenue	Local
175	16TH Street	Broad Street	1ST Avenue	Minor Arterial

#### 4.0 ROADWAY AND PARKING DESIGN

No.	Street	From	To	Classification
176	16TH Street	17TH Avenue	18TH Avenue	Local
177	16TH Street	12TH Avenue	Broad Street	Local
178	16TH Street	20TH Avenue	Opelika Road	Local
179	17TH Avenue	South Railroad Street	Crawford Road	Major Collector
180	17TH Avenue	24TH Street	26TH Street	Local
181	17TH Avenue	12TH Street	9TH Place South to End	Local
182	17TH Avenue	Crawford Road	12TH Place	Local
183	17TH Avenue	21ST Street	22ND Street	Local
184	17TH Avenue	5TH Street	4TH Place	Local
185	17TH Avenue	26TH Street	North to End	Local
186	17TH Avenue S	3RD Street S	1ST Place	Local
187	17TH Avenue S	Gloria Drive	End 7TH Street S	Local
188	17TH Court	13TH Street	13 TH Place	Local
189	17TH Place	21ST Court	Opelika Road	Local
190	17TH Street	27TH Avenue	28TH Avenue	Local
191	17TH Street	End to 14TH Avenue	17TH Avenue	Local
192	17TH Street	Wynn Road	East to End	Local
193	17TH Street	12TH Avenue	13TH Avenue	Local
194	17TH Street	7TH Avenue	9TH Avenue	Local
195	17TH Street	1ST Avenue	2ND Avenue	Local
196	17TH Street	Summerville Road	South Railroad Street	Local
197	17TH Street	4TH Avenue	6TH Avenue	Local
198	17TH Street	6TH Avenue	Summerville Road	Local
199	18TH Avenue	46TH Street	48TH Street	Local
200	18TH Avenue	37TH Street	North to End	Local
201	18TH Avenue	40TH Street	39TH Street	Local
202	18TH Avenue	13TH Place	13TH Street	Local
203	18TH Avenue	24TH Street	26TH Street	Local
204	18TH Avenue	South Railroad Street	15TH Street	Local
205	18TH Avenue	22ND Street	End	Local
206	18TH Avenue S	Abbot Drive	9TH Place to End	Local
207	18TH Court	South Railroad Street	End	Local
208	18TH Court	16TH Place	20TH Avenue	Local
209	18TH Court S	12TH Place S	11TH Place S	Local
210	18TH Place	18TH Avenue	East to End	Local
211	18TH Place	21ST Court	Opelika Road	Local
212	18TH Street	17TH Avenue	18TH Avenue	Local



## 4.0 ROADWAY AND PARKING DESIGN

No.	Street	From	To	Classification
213	19TH Avenue	Crawford Road	13TH Place	Local
214	19TH Avenue	18TH Court	16TH Place	Local
215	19TH Avenue	22ND Street	24th Street	Local
216	19TH Avenue	13TH Street	13TH Place	Local
217	19TH Avenue	4TH Street	Sandfort Road	Local
218	19TH Avenue	Tradition Way	Stadium Drive	Local
219	19TH Avenue S	Seale Road	11TH Place S	Local
220	19TH Court	Crawford Road	End	Local
221	19TH Street	1ST Avenue	6TH Avenue	Local
222	19TH Street	Summerville Road	6TH Court	Local
223	19TH Street	43RD Avenue	Wynn Road	Local
224	19TH Street	Summerville Road	10TH Avenue	Local
225	1ST Avenue	29TH Street	21ST Place	Local
226	1ST Avenue	32ND Street	End	Local
227	1ST Avenue	South Railroad Street	17TH Street	Local
228	1ST Avenue	21ST Place	North Railroad Street	Local
229	1ST Avenue South	6TH Place South	5TH Place South	Local
230	1ST Place	Seale Road	17TH Avenue	Local
231	1ST Place	8TH Avenue S	Seale Road	Local
232	1ST Place S	8TH Avenue S	10TH Avenue S	Local
233	1ST Place S	11TH Avenue S	East to End	Local
234	1ST Place S	11TH Avenue S	11TH Court S	Local
235	1ST Street	8TH Avenue S	10TH Avenue S	Local
236	1ST Street	10TH Avenue S	Seale Road	Local
237	1ST Street S	14TH Court	17TH Avenue S	Local
238	20TH Avenue	South Railroad Street	Crawford Road	Major Collector
239	20TH Avenue	46TH Street	Ashley Drive	Local
240	20TH Avenue	Crawford Road	14TH Street	Local
241	20TH Avenue	Sandfort Road	End	Local
242	20TH Avenue S	Seale Road	12TH Place S	Local
243	20TH Court	South Railroad Street	20TH Street	Local
244	20TH Street	1ST Avenue	6TH Avenue	Local
245	20TH Street	21ST Court	Opelika Road	Local
246	20TH Street	Auburn Road	End	Local
247	20TH Street	6TH Avenue	Summerville Road	Local
248	20TH Street	Blake Circle	20TH Court	Local
249	20TH Street	43RD Avenue	City Limits/Wynn Road	Local

## 4.0 ROADWAY AND PARKING DESIGN

No.	Street	From	To	Classification
250	20TH Street	Opelika Road	HWY 280/431 North	Local
251	20TH Street	14TH Avenue	11TH Court	Local
252	20TH Street	11TH Court	Summerville Road	Local
253	21ST Avenue S	Gateway Drive	End	Local
254	21ST Avenue	28TH Street	End	Local
255	21ST Avenue	Cul-de-sac	27TH Street	Local
256	21ST Avenue	18TH Street	Crawford Road	Local
257	21ST Avenue	24TH Street	Stadium Drive	Local
258	21ST Avenue	South Railroad Street	20TH Street	Local
259	21ST Avenue	Sandfort Road	North to end	Local
260	21ST Avenue	Sandfort Road	Keystone Subdivision	Local
261	21ST Avenue	27TH Street	Stadium Drive	Local
262	21ST Court	20TH Street	16TH Street	Local
263	21ST Place	5TH Avenue	6TH Avenue	Local
264	21ST Place	9TH Avenue	End	Local
265	21ST Place	5TH Avenue	1ST Avenue	Local
266	21ST Street	Summerville Road	9TH Avenue	Local
267	21ST Street	14TH Court	End	Local
268	21ST Street	1ST Avenue	6TH Avenue	Local
269	21ST Street	Summerville Road	14TH Court	Local
270	22ND Avenue	28TH Street	North to End	Local
271	22ND Avenue	46TH Street	Ridgeway Drive	Local
272	22ND Avenue	45TH Street @ Summerville Road	End	Local
273	22ND Avenue	Stadium Drive	24TH Street	Local
274	22ND Avenue	HWY 280 ACCESS Lane	7TH Street	Local
275	22ND Avenue	26TH Street	27TH Street	Local
276	22ND Avenue	27TH Street	28TH Street	Local
277	22ND Avenue	7TH Street	Sandfort Road	Local
278	22ND Street	17TH Avenue	14TH Court	Local
279	22ND Street	9TH Avenue	7TH Avenue	Local
280	22ND Street	19TH Avenue	Cul-de-sac	Local
281	22ND Street	12TH Avenue	14TH Court	Local
282	22ND Street	Summerville Road	12TH Avenue	Local
283	22ND Street	7TH Avenue	5TH Avenue	Local
284	23RD Avenue	28TH Street	End	Local
285	23RD Avenue	Lakewood Drive	45TH Street, west of Summerville Road	Local
286	23RD Avenue	End	Sandfort Road	Local

#### 4.0 ROADWAY AND PARKING DESIGN

No.	Street	From	To	Classification
287	23RD Court	13TH Place	South to End	Local
288	23RD Court	11TH ST	North to End	Local
289	23RD Court	Knowles Road	Sandfort Road	Local
290	23RD Place	1ST Avenue	End	Local
291	23RD Place	18TH Avenue	Cul-de-sac	Local
292	23RD Street	7TH Avenue	1ST Avenue	Local
293	23RD Street	Summerville Road, west side	11TH Avenue	Local
294	24TH Avenue	28TH Street	31ST Street	Local
295	24TH Avenue	Crawford Road	13TH Street	Local
296	24TH Avenue	7TH Street	9TH Street	Local
297	24TH Street	1ST Avenue	2ND Avenue	Local
298	24TH Street	4TH Avenue	2ND Avenue	Local
299	24TH Street	7TH Avenue	4TH Avenue	Local
300	24TH Street	Summerville Road, west side	End	Local
301	24TH Street	15TH Avenue	21ST Avenue	Local
302	25TH Avenue	26TH Avenue	40TH Street	Local
303	25TH Avenue	28TH Street	31ST Street	Local
304	25TH Avenue	14TH Street	13TH Street	Local
305	25TH Avenue	20TH Street	16TH Place	Local
306	25TH Avenue	9TH Street	7TH Street	Local
307	25TH Avenue	280 Access Lane	9TH Street	Local
308	25TH Court	7TH Street	6TH Street	Local
309	25TH Street	7TH Avenue	1ST Avenue	Local
310	25TH Street	18TH Avenue	17TH Avenue	Local
311	25TH Street	22ND Avenue	Cul-de-sac	Local
312	25TH Street	Summerville Road	7TH Avenue	Local
313	26TH Avenue	40TH Street	Brookwood Circle	Local
314	26TH Avenue	20TH Street	16TH Place	Local
315	26TH Avenue	7TH Street	End	Local
316	26TH Court	Sandfort Road	Randall Street	Local
317	26TH Street	7TH Avenue	3RD Avenue	Local
318	26TH Street	Summerville Road	8TH Avenue	Local
319	26TH Street	18TH Av	17TH Av	Local
320	26TH Street	N. Railroad Street	22ND Avenue	Local
321	26TH Street	17TH Avenue	16TH Av	Local
322	26TH Street	Summerville Road	11TH Court	Local
323	27TH Avenue	28TH Avenue	40TH Place	Local

#### 4.0 ROADWAY AND PARKING DESIGN

No.	Street	From	To	Classification
324	27TH Avenue	Crawford Road	28TH Avenue	Local
325	27TH Avenue	7TH Street	South to End	Local
326	27TH Avenue	7TH Street	End	Local
327	27TH Avenue	6TH Street	5TH Street	Local
328	27TH Court	End	17TH Street	Local
329	27TH Street	7TH Avenue	4TH Avenue	Local
330	27TH Street	N. Railroad Street	22ND Avenue	Local
331	27TH Street	13TH Avenue	11TH Court	Local
332	27TH Street	22ND Avenue	21ST Avenue	Local
333	28TH Avenue	40TH Street	27TH Avenue	Local
334	28TH Avenue	HWY 280/431 North	Crawford Road	Local
335	28TH Avenue	7TH Street	11TH Street	Local
336	28TH Avenue	6TH Street	5TH Street	Local
337	28TH Avenue	11TH Street	Crawford Road	Local
338	28TH Court	20TH Street	End	Local
339	28TH Place	Summerville Road, east side	End	Local
340	28th Place	15TH Avenue	16TH Avenue	Local
341	28TH Street	12TH Avenue	13TH Avenue	Local
342	28TH Street	22ND Avenue	21ST Avenue	Local
343	28TH Street	Summerville Road	4TH Avenue	Local
344	28TH Street	15TH Avenue	End	Local
345	28TH Street	13TH Avenue	15TH Avenue	Local
346	28TH Street	South Railroad Street	22ND Avenue	Local
347	29TH Avenue	7TH Street	End	Local
348	29TH Street	28TH Street	1ST Avenue	Local
349	29TH Street	15TH Avenue	Summerville Road, west side	Local
350	2ND Avenue	23RD Place	24TH Street	Local
351	2ND Avenue	N. Railroad Street	21ST Place	Local
352	2ND Avenue	South Railroad Street	16 TH Street	Local
353	2ND Place	11TH Avenue	12TH Avenue	Local
354	2ND Place S	14TH Avenue S	End	Local
355	2ND Place S	14TH Avenue S	End	Local
356	2ND Place S	10TH Avenue S	11TH CT S	Local
357	2ND Street	Seale Road	16TH Avenue	Local
358	2ND Street S	10TH Avenue S	11TH Avenue S	Local
359	2ND Street S	Seale Road	14TH Court	Local
360	2ND Street S	8TH Avenue S	10TH Avenue S	Local

#### 4.0 ROADWAY AND PARKING DESIGN

No.	Street	From	To	Classification
361	2ND Street S	Seale Road	11TH Court	Local
362	30TH Street	14TH Avenue	Summerville Road, west side	Local
363	30TH Street	Summerville Road, east side	4TH Avenue	Local
364	31ST Avenue	7TH Street	North to End	Local
365	31ST Street	25TH Avenue	24TH Avenue	Local
366	31ST Street	7TH Avenue	10TH Avenue	Local
367	32ND Street	Summerville Road, east side	11TH Avenue	Local
368	32ND Street	14TH Avenue	Summerville Road, west side	Local
369	32ND Street	10TH Avenue	9TH Avenue	Local
370	32ND Street	3RD Avenue	1ST Avenue	Local
371	32ND Street	9TH Avenue	7TH Avenue	Local
372	33RD Avenue	7TH Street	Wright Road	Local
373	33RD Avenue S	3RD Street S	End	Local
374	33RD Place	5TH Avenue	3RD Avenue	Local
375	33RD Street	14TH Avenue	Summerville Road, west side	Local
376	33RD Street	12TH Avenue	11TH Avenue	Local
377	34TH Avenue S	Sandfort Road	Knowles Road	Minor Collector
378	34TH Street	Summerville Road, east side	Idle Hour Drive	Local
379	35TH Street	Summerville Road, east side	Idle Hour Drive	Local
380	36TH Street	Summerville Road, east side	Idle Hour Drive	Major Collector
381	37TH Street	Stadium Drive	End	Local
382	37TH Street	Summerville Road, east side	Idle Hour Drive	Local
383	38TH Court	City Limits	City Limits	Local
384	39TH Court	Auburn Road	City Limits	Local
385	39TH Street	18TH Avenue	End	Local
386	39TH Street	16TH Avenue	Penrod Drive	Local
387	3RD Avenue	26TH Street	29TH Street	Local
388	3RD Avenue	33RD Place	32ND Street	Local
389	3RD Avenue	21ST Street	20TH Street	Local
390	3RD Place	End	14TH Avenue	Local
391	3RD Place	Seale Road	9TH Avenue	Local
392	3RD Place S	10TH Avenue S	11TH Avenue S	Local
393	3RD Place S	33RD Avenue S	34TH Avenue S	Local
394	3RD Place S	End East of 12th Av	Seale Road	Local

#### 4.0 ROADWAY AND PARKING DESIGN

No.	Street	From	To	Classification
395	3RD Place S	Seale Road	14TH Court	Local
396	3RD Place S	8TH Avenue S	10TH Avenue S	Local
397	3RD Street	Seale Road	11TH Avenue	Local
398	3RD Street S	10TH Avenue S	11TH Avenue S	Local
399	3RD Street S	Seale Road	East to End	Local
400	3RD Street S	33RD Avenue S	34TH Avenue S	Local
401	3RD Street S	8TH Avenue	9TH Avenue S. West to End	Local
402	3RD Street S	Seale Road	Martin Luther King Jr Parkway	Local
403	40TH Place	40TH Street	40TH Street	Local
404	40TH Street	Summerville Road	16TH Avenue	Local
405	40TH Street	Lakewood Drive	Summerville Road	Local
406	40TH Street	Martindale Drive	13TH Avenue	Local
407	40TH Street	Penrod Drive	Martindale Drive	Local
408	43RD Avenue	20TH Street	South to End	Local
409	43RD Street	Summerville Road	End	Minor Collector
410	45TH Street	Summerville Road	23RD Avenue	Local
411	45TH Street	Summerville Road, west side	15TH Avenue	Local
412	45TH Street	14TH Court	14TH Avenue	Local
413	46TH Street	Summerville Road	22ND Avenue	Local
414	46TH Street	Summerville Road	14TH Avenue	Local
415	47TH Street	20TH Avenue	18TH Avenue	Local
416	47TH Street	Summerville Road	16TH Avenue	Local
417	48TH Street	22ND Avenue	Summerville Road	Local
418	48TH Street	16TH Avenue	End	Local
419	4TH Avenue	Idle Hour Drive	21ST Place	Minor Arterial
420	4TH Avenue	16TH Street	21ST Place	Minor Arterial
421	4TH Avenue	Brickyard Road	End	Local
422	4TH Place	Seale Road	Knowles Road	Major Collector
423	4TH Place	16TH Avenue	End	Local
424	4TH Place S	8TH Avenue S	9TH Avenue S. West to End	Local
425	4TH Place S	10TH Avenue S	Seale Road	Local
426	4TH Street	Seale Road	11TH Avenue	Local
427	4TH Street	Seale Road	Colin Powell Pkwy	Local
428	4TH Street	21ST Avenue	End	Local
429	4TH Street S	Prentiss Drive.	East to End	Local
430	4TH Street S	10TH Avenue S	West to End	Local

## 4.0 ROADWAY AND PARKING DESIGN

No.	Street	From	To	Classification
431	4TH Street S	15TH Avenue S	16TH Avenue S	Local
432	4TH Street S	8TH Avenue S	9TH Avenue West to End	Local
433	4TH Street South	33RD Avenue South	End	Local
434	5TH Avenue	Airport Road	Idle Hour Drive	Minor Arterial
435	5TH Avenue	Dillingham Street	7TH Street	Major Collector
436	5TH Avenue	Idle Hour Drive	22ND Street	Local
437	5TH Avenue	21ST Place	21ST Street	Local
438	5TH Avenue	12TH Street	11TH Street	Local
439	5TH Avenue	16TH Street	14TH Street	Local
440	5TH Avenue	South Railroad Street	16TH Street	Local
441	5TH Avenue	6TH Street	End	Local
442	5TH Avenue	22ND Street	21ST Place	Local
443	5TH Avenue S	5TH Place S	6TH Place S	Local
444	5TH Place	Knowles Road	West to End	Local
445	5TH Place	7TH Avenue	Seale Road	Local
446	5TH Place S	11TH Avenue S	East to End	Local
447	5TH Place S	End to 1ST Avenue S	5TH Avenue S	Local
448	5TH Place S	Knowles Road	End	Local
449	5TH Street	16TH Avenue	17TH Avenue	Local
450	5TH Street	27TH Avenue	28TH Avenue	Local
451	5TH Street	33RD Avenue	End	Local
452	5TH Street S	8TH Avenue S	East to End	Local
453	5TH Street S	9TH Avenue S	10TH Avenue S	Local
454	5TH Street S	12TH Avenue S	10TH Avenue S	Local
455	5TH Street South	Knowles Road	431	Major Collector
456	5TH Street South	Seale Road	Martin Luther King Jr Parkway	Major Collector
457	6TH Avenue	North Railroad Street	22ND Street	Local
458	6TH Avenue	16TH Street	South Railroad Street	Local
459	6TH Avenue	8TH Street	7TH Street	Local
460	6TH Avenue	7TH Street	6TH Street	Local
461	6TH Court	North Railroad Street	20TH Street	Local
462	6TH Place	6TH Avenue	East to End	Local
463	6TH Place	Seale Road	East to Cul-de-sac	Local
464	6TH Place	7TH Street	Sandfort Road	Local
465	6TH Place S	Brickyard Road	Seale Road	Local
466	6TH Street	Colin Powell Pkwy	East to End	Local
467	6TH Street	Colin Powell Pkwy	Seale Road	Local

#### 4.0 ROADWAY AND PARKING DESIGN

No.	Street	From	To	Classification
468	6TH Street	25TH Court	27TH Court	Local
469	6TH Street	27TH Avenue	28TH Avenue	Local
470	6TH Street S	1ST Avenue S	5TH Avenue S	Local
471	6TH Street S	Fontaine Road	End	Local
472	7TH Avenue	25TH Street	North to End	Local
473	7TH Avenue	12TH Street	13TH Street	Local
474	7TH Avenue	20TH Street	22ND Street	Local
475	7TH Avenue	End North of 9TH Place	End S of Dillingham	Local
476	7TH Avenue	South Railroad Street	13TH Street	Local
477	7TH Avenue	7TH Street	5TH Place S to End	Local
478	7TH Avenue	22ND Street	25TH Street	Local
479	7TH Place	11TH Avenue	East to End	Local
480	7TH Place	Colin Powell Pkwy	Seale Road	Local
481	7TH Street	Colin Powell Pkwy	7TH Avenue	Local
482	7TH Street	33RD Avenue	24TH Avenue	Local
483	7TH Street	Brickyard Road	Colin Powell Pkwy	Local
484	7TH Street	24TH Avenue	Sandfort Road	Local
485	7TH Street S	Seale Road	17TH Avenue S	Local
486	7TH Street S	Seale Road	13TH Avenue S	Local
487	8TH Avenue	25TH Street	26TH Street	Local
488	8TH Avenue	9TH Street	Dillingham Street	Local
489	8TH Avenue	13TH Street	12TH Street	Local
490	8TH Avenue	End	Dillingham Street	Local
491	8TH Avenue	Shanna Court	25TH Street	Local
492	8TH Avenue	17TH Street	14TH Street	Local
493	8TH Avenue	5TH Place	West to End	Local
494	8TH Avenue	4TH Street	West to End	Local
495	8TH Avenue S	1ST Place S	2ND Street S	Local
496	8TH Avenue S	Meadowlane Drive	Fontaine Road	Local
497	8TH Court	Dillingham Street	9TH Street	Local
498	8TH Place	Martin Luther King Jr Parkway	8TH Street	Local
499	8TH Place	End East of 12TH Avenue	End	Local
500	8TH Place S	Seale Road	End	Local
501	8TH Street	7TH Court	Sandfort Road	Local
502	8TH Street	Sandfort Road	280 Frontage Road	Local
503	8TH Street	6TH Avenue	Seale Road	Local
504	8TH Street	27TH Avenue	28TH Avenue	Local



#### 4.0 ROADWAY AND PARKING DESIGN

No.	Street	From	To	Classification
505	8TH Street	26TH Avenue	East to End	Local
506	8TH Street	31ST Avenue	City Limits	Local
507	8TH Street S	15TH Avenue S	13TH Avenue S	Local
508	8TH Street S	Asbury Drive	Cul-de-sac	Local
509	9TH Avenue	26TH Street	25TH Street	Local
510	9TH Avenue	Idle Hour Drive	30TH Street	Local
511	9TH Avenue	William Boddie Street	Dillingham Street	Local
512	9TH Avenue	16TH Street	14TH Street	Local
513	9TH Avenue	25TH Street	22ND Street	Local
514	9TH Avenue	12TH Street	13TH Street	Local
515	9TH Avenue	22ND Street	20TH Street	Local
516	9TH Avenue	17TH Street	16TH Street	Local
517	9TH Avenue	14TH Street	13TH Street	Local
518	9TH Avenue	William Boddie Street	End	Local
519	9TH Avenue	3RD Place	End	Local
520	9TH Avenue S	3RD Street S	Fontaine Road	Local
521	9TH Avenue S	6TH Place S	Rodney Street	Local
522	9TH Court	South Railroad Street	16TH Street	Local
523	9TH Court	10TH Avenue	South to End	Local
524	9TH Place	17TH Avenue	18TH Avenue	Local
525	9TH Place	10TH Avenue	11TH Avenue	Local
526	9TH Place	11TH Avenue	13TH Avenue	Local
527	9TH Place	16TH Avenue	15TH Avenue	Local
528	9TH Place	8TH Avenue	9TH Avenue	Local
529	9TH Place	Broad Street	7TH Avenue	Local
530	9TH Place	28TH Avenue	Cul-de-sac	Local
531	9TH Place	31ST Avenue	End	Local
532	9TH Street	14TH Avenue	15TH Avenue	Local
533	9TH Street	11TH Avenue	End West of 12TH Avenue	Local
534	9TH Street	13TH Court	13TH Avenue	Local
535	9TH Street	End East of 8TH Avenue	Sandfort Road	Local
536	9TH Street	15TH Avenue	16TH Avenue	Local
537	9TH Street	25TH Avenue	24TH Avenue	Local
538	9TH Street S	Seale Road	13TH Avenue S	Local
539	Abbot Drive	17TH Avenue	12TH Street	Local
540	Abercrombie Road	Brickyard Road	City Limits	Local
541	Aberdeen Cir	Saint Andrews Way	End	Local

#### 4.0 ROADWAY AND PARKING DESIGN

No.	Street	From	To	Classification
542	Adie Street	16TH Avenue	Cul-de-sac	Local
543	Adrian Road	Chatman Drive	End	Local
544	Airport Road	Summerville Road	5TH Avenue	Major Collector
545	Alpha Court	Alpha Drive	Cul-de-sac	Local
546	Alpha Drive	Summerville Road	Pierce Road	Local
547	Alton Court	22ND Avenue	Cul-de-sac	Local
548	Amber Court	Sandfort Road	End	Local
549	Ann Marie Lane	Silver Leaf Loop	Silver Leaf Loop	Local
550	April Drive	End	End	Local
551	Asbury Court	Gloria Street	Cul-de-sac	Local
552	Asbury Drive	Epworth Street	8TH Street S	Local
553	Ashley Court	Ashley Drive	Cul-de-sac	Local
554	Ashley Drive	Summerville Road	22ND Avenue	Local
555	Atwood Drive	HWY 280/431	Phenix Drive	Local
556	Auburn Road	City Limits	Crawford Road	Major Collector
557	Autumn Haze Court	Summerfield Place	Cul-de-sac	Local
558	Autumn Leaf Court	Fall Branch Court	End	Local
559	Autumn Leaf Lane	Fall Branch Court	Autumn Leaf Court	Local
560	Balsa Drive	Misty Forest Drive	Red Maple Drive	Local
561	Bankstone Street	Gatewood Drive	Nancy Drive	Local
562	Beacon Street	Brookwood Circle	Karen Court	Local
563	Berry Court	Fontaine Road	Kaolin Drive South to End	Local
564	Bessant Drive	26TH Court	End	Local
565	Best Drive	Pierce Road	End	Local
566	Big Springs Drive	38TH Court	Britton Drive	Local
567	Billy Street	9TH Avenue S	Fontaine Road	Local
568	Blake Circle	21ST Avenue	20TH Street	Local
569	Blalock Circle	Pierce Road	End	Local
570	Blue Spruce Drive	White Pine Way	Misty Forest Drive.	Local
571	Bluebird Lane	City Limits	Cul-de-sac	Local
572	Brandywine Drive	Crosswinds Road	City Limits	Local
573	Brentview Drive	Fairfield Drive	End	Local
574	Brentwood Drive	Ph 1	Ph 1	Local
575	Briarwood Court	Pierce Road	Cul-de-sac	Local
576	Brickyard Road	Colin Powell Pkwy	City Limits	Minor Arterial
577	Brickyard Road	7TH Street	Colin Powell Pkwy	Major Collector
578	Brickyard Road	Twin Ridge Drive.	City Limits	Minor Arterial

#### 4.0 ROADWAY AND PARKING DESIGN

No.	Street	From	To	Classification
579	Bridgecrest Drive	Bridgewater Drive	End	Local
580	Bridgewater Circle	Sue Drive	Bridgewater Drive	Local
581	Bridgewater Court	Linda Drive	Bridgewater Drive	Local
582	Bridgewater Drive	Lakewood Drive	Park Drive	Major Collector
583	Bridgewater Drive	Park Drive	End	Local
584	Bridle Court	Walker Court	Cul-de-sac	Local
585	Brighton Court	Janet Drive	Cul-de-sac	Local
586	Bristol Lane	New Castle Drive	End	Local
587	Britton Drive	Big Springs Drive	End	Local
588	Broad Street	Martin Luther King Jr. Parkway	Dillingham Street	Principal Arterial
589	Broad Street	Crawford Road	Dillingham Street	Principal Arterial
590	Broad Street	Dillingham Street	Summerville Road (bridge)	Local
591	Brookwood Circle	26TH Avenue	Brookwood Drive	Local
592	Brookwood Court	26TH Avenue	Creekstone Drive	Local
593	Brookwood Drive	40TH Street	26TH Street	Local
594	Buford Drive	Lockhart Circle	Jackson Drive	Local
595	Builder Drive	7TH Street	End	Local
596	Bussey Drive	6TH Avenue	Garrett Circle	Local
597	Calpatrick Street	Dottie Drive	Gatewood Drive	Local
598	Cambree Court	Linda Drive	End	Local
599	Cambridge Court	Lincolnshire Lane	Cul-de-sac	Local
600	Canopy Court	Carrington Place	Cul-de-sac	Local
601	Canter Drive	Summerville Road	End	Local
602	Carriage Drive	Summerville Road, west side	Cul-de-sac	Local
603	Carrington Place	Lakewood Drive	Cul-de-sac	Local
604	Cascade Way	Creekstone Lane	Cul-de-sac	Local
605	Cater Court	Overlook Drive	Cul-de-sac	Local
606	Catherine Drive	Jane Avenue	End	Local
607	Cedarside Drive	Knowles Road	End	Local
608	Cedarwood Court	Cul-de-sac	Cul-de-sac	Local
609	Cedarwood Lane	Springwood Drive	Cedarwood Court	Local
610	Chariot Court	Carrington Place	Cul-de-sac	Local
611	Chatman Drive	Lonesome Pine Road	East to End	Local
612	Clay Court	Wehring Lane	South to End	Local
613	Clover Court (aka Shannon)	Silver Lake Drive	Cul-de-sac	Local
614	Colin Powell Pkwy	Martin Luther King Jr Parkway	Brickyard Road	Minor Arterial

## 4.0 ROADWAY AND PARKING DESIGN

No.	Street	From	To	Classification
615	College Drive	Engineer Drive	HWY 431/Grand Reserve	Local
616	College Drive	HWY 431	Engineer Drive	Local
617	Coventry Court	New Castle Drive	End	Local
618	Crane Court	Bridgewater Circle	Cul-de-sac	Local
619	Crawford Road	HWY 431/280	East City Limits	Principal Arterial
620	Creekstone Court	Creekstone Drive	Cul-de-sac	Local
621	Creekstone Drive	Brookwood Court	Creekstone Lane	Local
622	Creekstone Lane	Cul-de-sac	Cascade Way	Local
623	Crestwood Court	Oakwood Drive	Cul-de-sac	Local
624	Crosswinds Road	Cedar Lane.	Hwy 431 S	Minor Collector
625	Culpepper Drive	Pierce Road	Hussey Driveway	Local
626	Cumberland Drive	Nottingham Drive	End	Local
627	Cypress Court	Redwood Drive	Cul-de-sac	Local
628	Dawkins Court	Adie Street	Cul-de-sac	Local
629	Day Lily Court	Cul-de-sac	Phase 2	Local
630	Debbie Court	Debbie Circle	End	Local
631	Delbrock Court	Delbrock Drive	End	Local
632	Delbrock Drive	Cedarside Drive	End	Local
633	Denard Drive	Beacon Street	End	Local
634	Devonshire Drive	Lincolnshire Lane	Lincolnshire Lane	Local
635	Dillingham Street	5TH Avenue	Broad Street	Minor Arterial
636	Dillingham Street	11TH Avenue	Broad Street	Minor Arterial
637	Dillingham Street	11TH Court	11TH Avenue	Local
638	Dobbs Drive	Opelika Road	Auburn Road	Local
639	Dottie Drive	Gatewood Drive	Gatewood Drive	Local
640	Dovecrest Court	Pierce Road	City Limits	Local
641	Downing Drive	US HWY 431	Old Seale HWY	Local
642	Dunbar Circle	Saint Andrews Way	End Cul-de-sac	Local
643	Dundee Court	Saint Andrews Way	End Cul-de-sac	Local
644	Elm Court	Tree Top Hill	Cul-de-sac	Local
645	Elmridge Drive	End	Phase 2	Local
646	Engineer Drive	College Drive	Seale Road	Local
647	Epworth Street	17TH Avenue S	End	Local
648	Evans Road	US HWY 80 W	North to City Limits	Local
649	Explorer Drive	Pierce Road	Silver Lake Drive	Major Collector
650	Fairfield Drive	Sandfort Road	Ph 1	Local
651	Fall Branch Circle	Fall Branch Drive	End	Local

#### 4.0 ROADWAY AND PARKING DESIGN

No.	Street	From	To	Classification
652	Fall Branch Court	Fall Branch Drive	End	Local
653	Fall Branch Drive	McIntosh Creek Road	End	Local
654	Fletcher Drive	Summerville Road	End	Local
655	Fontaine Road	10TH Avenue S	6TH Place S	Major Collector
656	Fontaine Road	6TH Place S	RR Tracks	Major Collector
657	Forest Ridge Court	Forest Ridge Lane	Cul-de-sac	Local
658	Forest Ridge Lane	Ph 1	Brentwood Drive	Local
659	Forest Ridge Lane	Brentwood Drive	Cul-de-sac	Local
660	Four Season Drive	End	End	Local
661	Garrett Circle	1ST Avenue S	6TH Place S	Local
662	Gateway Drive	Martin Luther King Jr Parkway	8TH Place S	Local
663	Gatewood Drive	Opelika Road	Dottie Drive	Local
664	George Court	Melanie Lane	End	Local
665	Glenwood Way	City Limits	End	Local
666	Gloria Street	Epworth Street	Cul-de-sac	Local
667	Gloyd Point Way	Aberdeen Drive.	End	Local
668	Green Wing Lane	Mallard Creek Drive	Teal Drive	Local
669	Greenbriar Drive	Brookwood Court	Beacon Street	Local
670	Greenwich Drive	Midway Drive	End	Local
671	Grey Moss Cove	River Oak Way	Loop	Local
672	Greystone Court	Glenwood Way	Cul-de-sac	Local
673	Grinding Stone Lane	Grist Mill Drive	River Oak Way	Local
674	Grist Mill Court	Grist Mill Drive	Cul-de-sac	Local
675	Grist Mill Drive	Riverchase Drive.	Cul-de-sac	Local
676	Grist Mill Isle	Grist Mill Court	Cul-de-sac	Local
677	Harding Drive	Fairfield Drive	End	Local
678	HawThorn Lane	Hunter Lane	Briarwood Court	Local
679	Heather Court	Silver Lake Drive	Cul-de-sac	Local
680	Henry Court	Melanie Lane	End	Local
681	Hickoryridge Drive	Elmridge Drive	Ridgewood Drive	Local
682	Hillside Court	Hillside Drive	Hillside Drive	Local
683	Hillside Drive	Evans Road	Cul-de-sac	Local
684	Holiday Circle	Lynn Drive	Cul-de-sac	Local
685	Holland Court	South Railroad Street	Cul-de-sac	Local
686	Hummingbird Court	Hunter Lane	Cul-de-sac	Local
687	Hunter Lane	Pierce Road	Thornberry Circle	Local
688	Hydrangea Drive	Summerville Road	Day Lily Court	Local

#### 4.0 ROADWAY AND PARKING DESIGN

No.	Street	From	To	Classification
689	Idle Hour Drive	5TH Avenue	36TH Street	Major Collector
690	Industrial Circle	State Docks Road	State Docks Road	Local
691	Industrial Drive	Seale Road	Northwest to End	Local
692	Ingersol Court	17TH Avenue	13TH Place	Local
693	Ingersoll Drive	12TH Place	HWY 280/431North	Local
694	Ingersoll Drive	Crawford Road	12TH Place	Local
695	Inverness Drive	Saint Andrews Way	End Cul-de-sac	Local
696	Iona Drive	Lynn Drive	End	Local
697	Iris Drive	Lakewood Drive	Apartment Parking Lot	Local
698	Issac Street	Jason Drive	Ridgebrook Drive.	Local
699	Ivy Cross	Ivy Lane	Ivy Loop	Local
700	Ivy Lane	Landmark Road	End Phase I	Local
701	Ivy Loop	Ivy Lane	End Phase I	Local
702	Ivy Way	Ivy Lane	Ivy Loop	Local
703	Jackson Drive	End to Buford Drive	Lockhart Circle to End	Local
704	Jacob Drive	Ridgebrook Drive	Jason Drive	Local
705	Jamestown Court	Cul-de-sac	East to End	Local
706	Janet Drive	Summerville Road	End	Local
707	Jason Drive	Rusty Drive	Issac Street	Local
708	Jefferson Drive	Brandywine Drive	Jamestown Court	Local
709	Jefferson Road	Jamestown Court	South to End	Local
710	John Bussey Drive	State Docks Road	End	Local
711	Kadie Court	Catherine Drive	End	Local
712	Kalin Drive	Peacock Drive	Ridgebrook Drive.	Local
713	Kalin Street	Peacock Drive	Ridgebrook Drive.	Local
714	Kaolin Drive	Berry Court	Wehring Lane	Local
715	Karen Court	Cul-de-sac	Cul-de-sac	Local
716	Katie Drive	City Limits	Ridgebrook Drive.	Local
717	Kelly Court	Greenbriar Drive	End	Local
718	Kennon Court	Tillery Lane	Cul-de-sac	Local
719	Kimball Drive	End to Lincoln Drive	April Drive to End	Local
720	Kimberly Drive	Brookwood Circle	Iona Drive	Local
721	King Drive	Kaolin Drive	Wehring Lane	Local
722	Kirkealdy Drive	Saint Andrews Way	Cul-de-sac	Local
723	Kittrell Drive	Auburn Road	End	Local
724	Knowles Road	4TH Place	16TH Avenue.	Major Collector
725	Knowles Road	City Limits	HWY 431	Major Collector

#### 4.0 ROADWAY AND PARKING DESIGN

No.	Street	From	To	Classification
726	Knowles Road	Seale Road	Dead End	Local
727	Lach-Lamond Point	Saint Andrews Way	Cul-de-sac	Local
728	Lake Court	Millpond Drive	Cul-de-sac	Local
729	Lake Lane	Mill Pond Lane	Cul-de-sac	Local
730	Lake Place	Mill Pond Street	Cul-de-sac	Local
731	Lakeview Court	Britton Drive	Cul-de-sac	Local
732	Lakewood Circle	28TH Avenue	Cul-de-sac	Local
733	Lakewood Drive	Summerville Road	South Railroad Street	Major Collector
734	Lakewood Drive	Opelika Road	Railroad Tracks	Major Collector
735	Lakewood Drive	South Railroad Street	Railroad Tracks	Major Collector
736	Lakewood Park Drive	Silver Lake Drive	Cul-de-sac	Local
737	Lakewood Place	Lakewood Drive	Cul-de-sac	Local
738	Lakewood Villas Court	Lakewood Park Drive	Cul-de-sac	Local
739	Landau Drive	Surrey Lane	Cul-de-sac	Local
740	Landfill Road	Old Seale Highway	End of Pavement	Local
741	Larry Court	9TH Avenue S	End	Local
742	Lawrence Court	6TH Place S	End	Local
743	Leah Court	Ridgebrook Drive	Cul-de-sac	Local
744	Lee Road 873	City Limits	City Limits	Local
745	Leisure Avenue	40TH Street	Lynn Drive	Local
746	Lemon Way	Willow Snapper Lane	Cul-de-sac	Local
747	Level Court	Builder Drive	End	Local
748	Lexington Circle	Fairfield Drive	Fairfield Drive	Local
749	Lincoln Drive	Kimball Drive	April 2014 Drive	Local
750	Lincolnshire Lane	Stafford Road	Cul-de-sac	Local
751	Linda Drive	Bridgewater Court	End	Local
752	Lockhart Circle	6TH Place S	Jackson Drive	Local
753	Lonesome Pine Court	Lonesome Pine Road	Cul-de-sac	Local
754	Lonesome Pine Road	Seale Road	End of Pavement	Local
755	Lynn Drive	Iona Drive	Kimberly Drive	Local
756	Maggy Court	Explorer Drive	Cul-de-sac	Local
757	Magnolia Court	Summerville Road	Apartment Parking Lot	Local
758	Magnolia Place	Summerville Road	Cul-de-sac	Local
759	Mallard Creek Drive	City Limits	Cul-de-sac	Local
760	Maple Court	Beacon Street	End	Local
761	Martindale Drive	Thayer Drive	40TH Street	Local
762	Mason Court	McIntosh Creek Road	Cul-de-sac	Local

#### 4.0 ROADWAY AND PARKING DESIGN

No.	Street	From	To	Classification
763	Mays Street	Sanks Drive	East to End	Local
764	McIntosh Creek Court	McIntosh Creek Road	Cul-de-sac	Local
765	McIntosh Creek Road	Summerville Road	Cul-de-sac	Local
766	McIntosh Estates Court	Riverchase Drive.	Cul-de-sac	Local
767	Meadowlane Drive	10TH Avenue S	Brickyard Road	Major Collector
768	Megan Street	Peacock Drive	Ridgebrook Drive	Local
769	Melanie Lane	Summerville Road	Riverchase Drive	Minor Collector
770	Midway Drive	Knowles Road	End	Local
771	Mill Pond Court	Mill Pond Drive	Cul-de-sac	Local
772	Mill Pond Drive	Crawford Road	Mimosa Drive	Local
773	Mill Pond Lane	Mill Pond Street	Cul-de-sac	Local
774	Mill Pond Street	Mill Pond Drive	Mimosa Drive	Local
775	Millstone Drive	Grist Mill Drive	End	Local
776	Mimosa Road	County Line	North to City Limits	Local
777	Misty Forest Drive	White Pine Way	Blue Spruce Drive	Local
778	Martin Luther King Jr Parkway, North Lane	8TH Place	Broad Street	Principal Arterial
779	Martin Luther King Jr Parkway, North Lane	8TH Place	HWY 280/431North	Local
780	Martin Luther King Jr Parkway, South Lane	8TH Place	Broad Street	Principal Arterial
781	Martin Luther King Jr Parkway, South Lane	8TH Place	HWY 280/431 North	Local
782	Monarett Drive (17TH Avenue S	Ridgecrest Drive	Gloria Drive	Local
783	Morning Dove Court	Hunter Lane	Cul-de-sac	Local
784	Moses Place	Broyles Road	Cul-de-sac	Local
785	Mullins Drive	End	End	Local
786	N 5TH Place	Knowles Road	End	Local
787	Nail Court	Builder Drive	End	Local
788	Nancy Drive	Gatewood Drive	Gatewood Drive	Local
789	New Castle Drive	Stafford Road	End	Local
790	North Railroad Street	14TH Avenue	16TH Avenue	Local
791	North Railroad Street	Dead End	4TH Avenue	Local
792	North Railroad Street	1ST Avenue	4TH Avenue	Local
793	North Railroad Street	26TH Street	28TH Street	Local
794	North Railroad Street	13TH Avenue	14TH Avenue	Local
795	North Railroad Street	Summerville Road	11TH Court	Local
796	Nottingham Drive	45TH Street @ Summerville	End	Local
797	Oakwood Court	Oakwood Drive	Cul-de-sac	Local



#### 4.0 ROADWAY AND PARKING DESIGN

No.	Street	From	To	Classification
798	Oakwood Drive	Lee Road 219	Cul-de-sac	Local
799	Old State Road	Lonesome Pine Road	George Williams Road	Local
800	Oliver Trail Lane	Riverchase Drive.	End	Local
801	Opelika Road	HWY 280	Northwest to City Limits	Minor Arterial
802	Opelika Road	HWY 280	Crawford Road	Minor Arterial
803	Orchard Street	End	End	Local
804	Overlook Drive	South Railroad Street	Cul-de-sac	Local
805	Park Avenue	HWY 280/431 North	7TH Street	Local
806	Park Drive	Bridgewater Drive	End	Local
807	Parkview Court	19TH Avenue	Cul-de-sac	Local
808	Paul Drive	22ND Avenue	48TH Street	Local
809	Peachtree Court	Forest Ridge Court	Cul-de-sac	Local
810	Peacock Drive	City Limits	Cul-de-sac	Local
811	Penrod Drive	39TH Street	Cul-de-sac	Local
812	Phenix Drive	HWY 280/431	Pierce Road	Local
813	Phillips Drive	27TH Avenue	West to End	Local
814	Pierce POINT Drive	Pierce Road	Cul-de-sac	Local
815	Pine Hill Court	7TH Street	End	Local
816	Pine Street	17TH Avenue	17TH Court	Local
817	Prentiss Drive	3RD Street S	5TH Street South	Local
818	Preswick Drive	St. Andrews Way	End	Local
819	Prince Drive	Kaolin Drive	Wehring Lane	Local
820	Randell Court	Randell Street	Cul-de-sac	Local
821	Randell Street	Cul-de-sac	End	Local
822	Red Maple Drive	Misty Forest Drive	Blue Spruce Drive	Local
823	Red Maple Street	White Pine Way	Sweet Birch Drive	Local
824	Redwood Drive	Misty Forest Drive	Loops back to itself	Local
825	Retail Drive	College Drive	Cul-de-sac	Local
826	Richards Drive	Riverchase Drive.	End	Local
827	Richburg Street	Cedarside Drive	Midway Drive	Local
828	Richmond Park Drive	Knowles Road	End	Local
829	Ridgebrook Drive	Peacock Drive	Nuckols Road	Local
830	Ridgecrest Drive	Epworth Street	End	Local
831	Ridgeway Drive	Janet Drive	22ND Avenue	Local
832	Ridgewood Drive	Dobbs Drive	Elmridge Drive	Local
833	Ridgewood Way	Elm Ridge Drive	End	Local
834	River Oak Way	Grey Moss Cove	End	Local

## 4.0 ROADWAY AND PARKING DESIGN

No.	Street	From	To	Classification
835	Riverchase Drive	Airport Road	Summerville Road	Minor Arterial
836	Rock Island Lane	Stoney Brooke Drive	End	Local
837	Rodney Street	6TH Place S	Lincoln Drive	Local
838	Rose Mount Circle	Old Seale Road	Loops back to itself	Local
839	Rusty Drive	Peacock Drive	Cul-de-sac	Local
840	Ryan Loop	Fairfield Drive	Fairfield Drive	Local
841	S 11TH Avenue	12TH Avenue	11TH Avenue S	Local
842	S 2ND Place	10TH Avenue	11TH Court	Local
843	S 4TH Place	S Seale Road	10TH Avenue	Local
844	S Seale Road	10TH Avenue S	5TH Street S	Minor Arterial
845	S Seale Road	5TH Street S	City Limits	Minor Arterial
846	Sandfort Road	Dillingham Street	HWY 280	Minor Arterial
847	Sandfort Road	7TH Street	City Limits	Major Collector
848	Sandfort Road	7TH Street	HWY 280	Major Collector
849	Sanks Drive	Rose Mount Cir.	South to End	Local
850	Sawgrass lane	Lakewood Drive	IT Circle S	Local
851	Scarlett Drive	Janet Drive	Cul-de-sac	Local
852	Scenic Drive	6TH Place	End	Local
853	Scott Drive	Pierce Road	City Limits	Local
854	Seale Road	HWY 280	10TH Avenue S	Minor Arterial
855	Seale Road	HWY 280	Broad Street	Minor Arterial
856	Serene Court	Tranquil Lane	Cul-de-sac	Local
857	Shadow Wood Drive	City Limits	City Limits	Local
858	Shadow Wood Lane	Shadow Wood Drive	End	Local
859	Shady Wood Court	Shadow Wood Drive	Cul-de-sac	Local
860	Shanna Court	21ST Street	Cul-de-sac	Local
861	Shenandoah Drive	Windermere Court	Cul-de-sac	Local
862	Silver Lake Drive	Bridgewater Drive	Explorer Drive	Major Collector
863	Silver Lake Drive	Explorer Drive	Cul-de-sac	Local
864	Silver Leaf Court	Silver Leaf Loop	Cul-de-sac	Local
865	Silver Leaf Drive	Explorer Drive	Silver Leaf Loop	Local
866	Silver Leaf Loop	Maggy Court	Loops to Maggy Court	Local
867	Silver Leaf Way	Silver Leaf Loop	Explorer Drive	Local
868	Silver Terrace Court	Cul-de-sac	Cul-de-sac	Local
869	Silver Terrace Drive	Bridgecrest Drive	Silver Terrace Court	Local
870	Sitka Court	Willow Branch Drive	Cul-de-sac	Local
871	Slappy Drive	Lee Road 0308	City Limits	Local

#### 4.0 ROADWAY AND PARKING DESIGN

No.	Street	From	To	Classification
872	South Railroad Street	17TH Street	Railroad Tracks	Minor Arterial
873	South Railroad Street	Railroad Tracks	End	Minor Arterial
874	South Railroad Street	6TH Avenue	West to End	Local
875	South Railroad Street	1ST Avenue	2ND Avenue	Local
876	South Railroad Street	2ND Avenue	6TH Avenue	Local
877	Sportsman Drive	HWY 280/431 North	East to End	Local
878	Springfield Court	Summerfield Place	End	Local
879	Springwood Court	Springwood Drive	Cul-de-sac	Local
880	Springwood Drive	Oakwood Drive	Cul-de-sac	Local
881	Saint Andrews Way	Summerville Road	End Cul-de-sac	Local
882	St Clair Drive	Windermere Court	Cul-de-sac	Local
883	Stadium Drive	South Railroad Street	Opelika Road	Major Collector
884	Stadium Drive	North edge of the Gardens	Summerville Road	Major Collector
885	Stadium Drive	South Railroad Street	22ND Avenue	Major Collector
886	Stadium Drive	22nd Avenue	19TH Avenue	Major Collector
887	Stadium Drive	19TH Avenue	North edge of The Gardens	Major Collector
888	State Docks Road	Brickyard Road	East to End	Major Collector
889	Sterling Drive	Lee Road 248	End	Local
890	Stonedale Court	Glenwood Way	Cul-de-sac	Local
891	Stoneybrook Drive	Oliver Trail Lane	River Oak Way	Local
892	Sue Drive	Bridgewater Court	Bridgewater Circle	Local
893	Summer Circle	7TH Street	End	Local
894	Summerbrook Lane	Pierce Road	Cul-de-sac	Local
895	Summerfield Lane	Summerfield Place	Four Seasons Drive	Local
896	Summerfield Place	Summerville Road	Cul-de-sac	Local
897	Summerplace Drive	15TH Avenue	Cul-de-sac	Local
898	Summerville Road	25TH Street	Broad Street	Minor Arterial
899	Summerville Road	Carriage Drive	300FT North of 37TH Street	Minor Arterial
900	Summerville Road	Saint Andrews Way	Carriage Drive	Minor Arterial
901	Summerville Road	300FT North of 37TH Street	26TH Street	Minor Arterial
902	Summerville Road	25TH Street	26TH Street	Minor Arterial
903	Summerwind Drive	Knowles Road	Cul-de-sac	Local
904	Summit Court	Summit Drive	End	Local
905	Summit Drive	McIntosh Creek Road	End	Local
906	Sunny Lane	Summerwind Drive	Cul-de-sac	Local
907	Sunwood Drive	Shadow Wood Lane	Shadow Wood Drive	Local

#### 4.0 ROADWAY AND PARKING DESIGN

No.	Street	From	To	Classification
908	Sunwood Drive	Shadow Wood Lane	End	Local
909	Sunwood Drive	Shadow Wood Drive	End	Local
910	Sunwood Drive	Shadow Wood Drive	Shadow Wood Lane	Local
911	Surrey Lane	Lakewood Drive	40TH Street	Local
912	Sweet Birch Drive	White Pine Way	Red Maple Street	Local
913	Sycamore Drive	Crosswinds Road	City Limits	Local
914	Taurus Court	Orchard Street	End	Local
915	Teal Drive	City Limits	Cul-de-sac	Local
916	Thayer Drive	43RD Street	End	Local
917	Thornberry Circle	Hunter Lane	End	Local
918	Tillery Lane	South Railroad Street	Cul-de-sac	Local
919	Timberland Drive	Stadium Drive	End	Local
920	Timothy Court	Bridgewater Court	Cul-de-sac	Local
921	Tony Drive	Mays Street	North to End	Local
922	Tradition Court	Tradition Way	Cul-de-sac	Local
923	Tradition Way	19TH Avenue	17TH Avenue	Local
924	Trafford Trail	Lincolnshire Lane	Lincolnshire Lane	Local
925	Tranquil Lane	Kimberly Drive	Cul-de-sac	Local
926	Tree Top Hill	Shadow Wood Lane	Cul-de-sac	Local
927	University Place	Seale Road	College Drive	Local
928	Wales Way	Lincolnshire Lane	Cul-de-sac	Local
929	Walker Court	Cul-de-sac	Cul-de-sac	Local
930	Wally Lane	Silver Leaf Loop	Silver Leaf Loop	Local
931	Wehring Lane	Fontaine Road	Kaolin Drive	Local
932	Westminster Drive	Auburn Road	Cul-de-sac	Local
933	White Fir Drive	Misty Forest Drive	Blue Spruce Drive	Local
934	White Pine Way	Misty Forest Drive	Misty Forest, PH 2	Local
935	Whitewater Avenue	16TH Street	13TH Street	Minor Arterial
936	William Boddie Street (10TH Street)	8TH Avenue	10TH Avenue	Local
937	Williams Avenue	Cul-de-sac	End	Local
938	Williamsburg Drive	Brandywine Drive	South to End	Local
939	Willow Branch Drive	Sitka Court	Cul-de-sac	Local
940	Willow Court	Willow Trace Drive	Cul-de-sac	Local
941	Willow Snapper Lane	Willow Trace Drive	Willow Branch Drive	Local
942	Willow Trace Drive	Forest Ridge Lane	Knowles Road	Local
943	Wilma Avenue	Pierce Road	End	Local
944	Windermere Court	Silver Lake Drive	Cul-de-sac	Local

#### 4.0 ROADWAY AND PARKING DESIGN

No.	Street	From	To	Classification
945	Windmark Court	Williams Avenue	End	Local
946	Windsweep Court	Price Road	Cul-de-sac	Local
947	Windy Lane	22ND Avenue	Williams Avenue	Local
948	Winter Green Court	Summerfield Place	End	Local
949	Wisteria Drive	Brickyard Road	End	Local
950	Woodchase Court	Woodchase Drive	Cul-de-sac	Local
951	Woodchase Drive	Oakwood Drive	Cul-de-sac	Local
952	Woodmere Court	Oakwood Drive	Cul-de-sac	Local
953	Woody Lane	Jefferson Road	End	Local
954	Wright Road	Sandfort Road	Northwest to City Limits	Minor Collector
955	Wright Road	Crawford Road	City Limits	Minor Collector
956	Wynn Road	20TH Street	19TH Street	Local
957	Wynn Road	Harbuck Drive	Thornhill Drive	Local

***If a road is not listed, contact the Phenix City Engineering and Public Works Department for the street classification.***

DRAFT

**APPENDIX 4B**  
**STANDARD DRAWINGS AND DETAILS**

DRAFT

DRAFT



**TYPICAL ROAD SECTION  
WITH CURB & GUTTER**

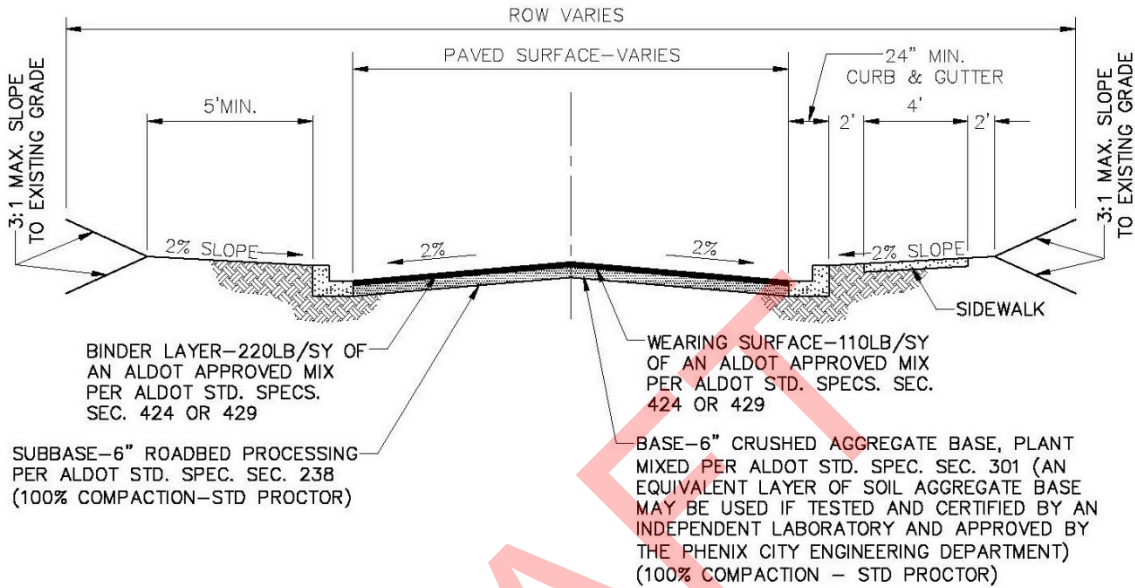

**NOTES**

1. PRIME COAT SHALL BE PLACED ON BASE AS REQUIRED BY THE PHENIX CITY ENGINEERING DEPARTMENT.
2. TACK COAT SHALL BE PLACED AS REQUIRED BY THE PHENIX CITY ENGINEERING DEPARTMENT.
3. THE WEARING SURFACE SHALL BE PLACED DURING A PERIOD OF 9 TO 12 MONTHS AFTER PLACEMENT OF BINDER LAYER.

CLASSIFICATION	MINIMUM WIDTH OF PAVEMENT	MINIMUM WIDTH FROM BACK OF CURB	MINIMUM WIDTH OF R.O.W.	SIDEWALK REQUIRED
LOCAL STREET (LOW DENSITY)	24	28	60	ONE SIDE
LOCAL STREET	27	31	60	ONE SIDE
MINOR COLLECTOR STREET	30	35	60	ONE SIDE
MAJOR COLLECTOR STREET	36	41	60	BOTH SIDES
ARTERIAL	48	53	80	BOTH SIDES

DRAFT

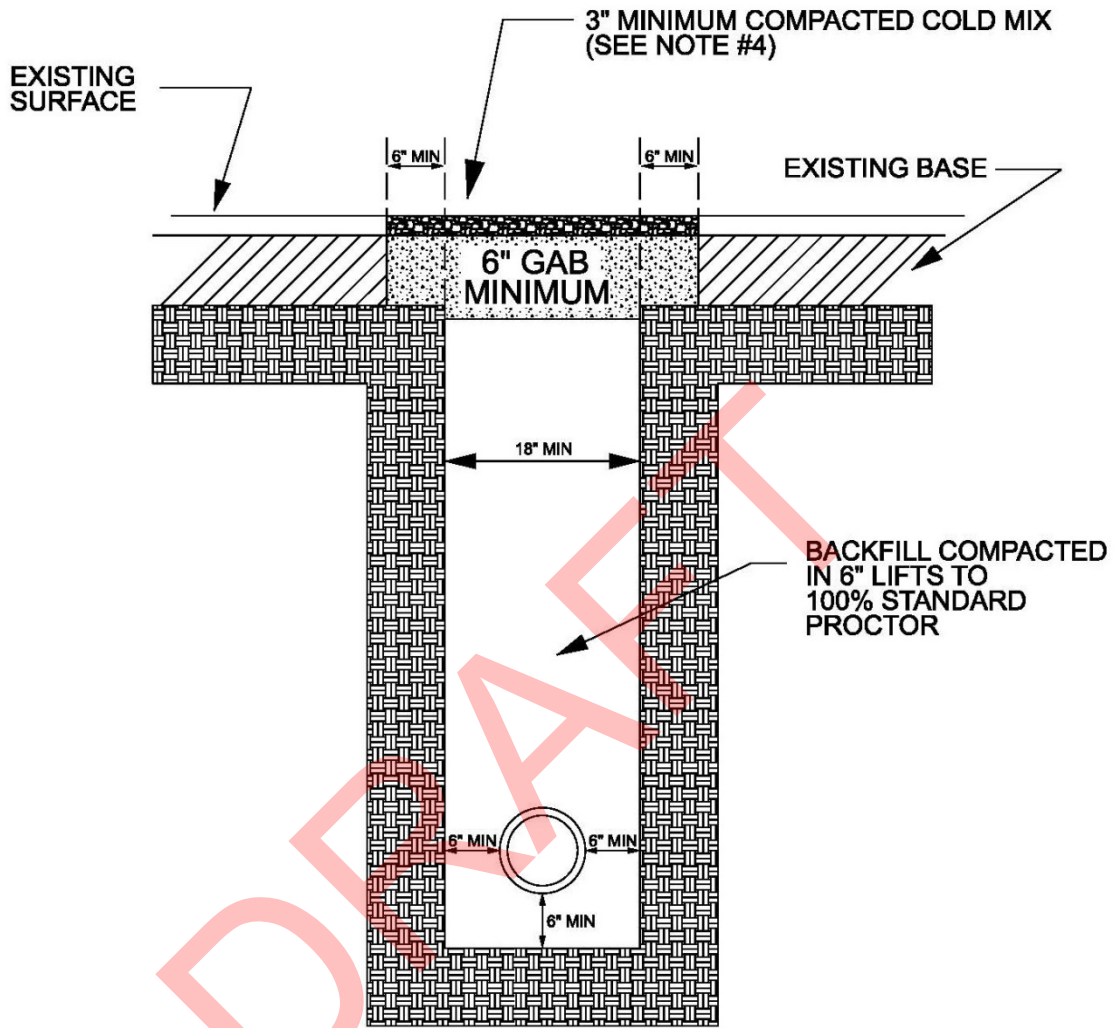

**TEMPORARY PATCH DETAIL**

NOT TO SCALE

**NOTES:**

1. ALL PAVEMENT SHALL BE SAWCUT, SQUARE. SAWCUTS SHALL NOT EXTEND BEYOND THE INTERSECTION OF CUTS AT CORNERS.
2. TEMPORARY PATCHING TO MATCH CONTOUR OF EXISTING SURFACE.
3. EVERY PIPE OR CONDUIT FOR WATER, SEWAGE, GAS, DRAINAGE, COMMUNICATION, OR ANY OTHER UTILITY SHALL NOT BE RAISED ABOVE EXISTING ELEVATION.
4. COLD MIX ASPHALT MATERIAL MUST MEET REQUIREMENTS FOR ALDOT QUALIFIED MATERIALS LIST III-5 PATCHING MATERIAL FOR BITUMINOUS CONCRETE PAVEMENT.

DRAFT

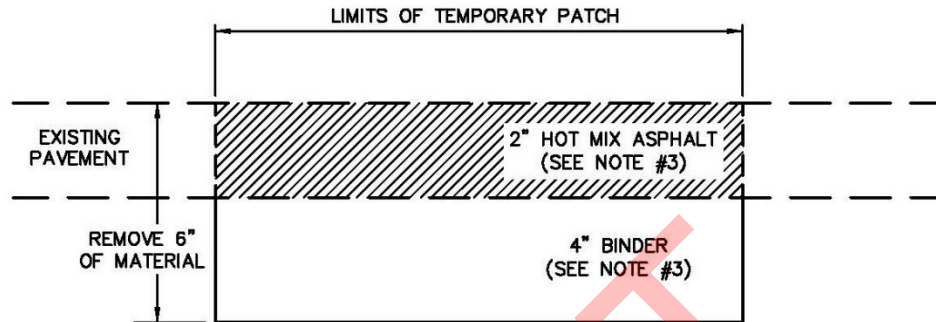
**PERMANENT PATCH DETAIL****NOTES**

1. SAW-CUT AND REMOVE PATCH AND BASE TO DEPTH OF SIX (6) INCHES.
2. PLACE TACK ON ALL VERTICAL SURFACES.
3. PLACE FOUR (4) INCHES OF BINDER AND TWO (2) INCHES OF HOT MIX ASPHALT MEETING REQUIREMENTS OF ALDOT SPECIFICATIONS SECTION 424.
4. PERMANENT PATCH TO MATCH CONTOUR OF EXISTING SURFACE.

DRAFT

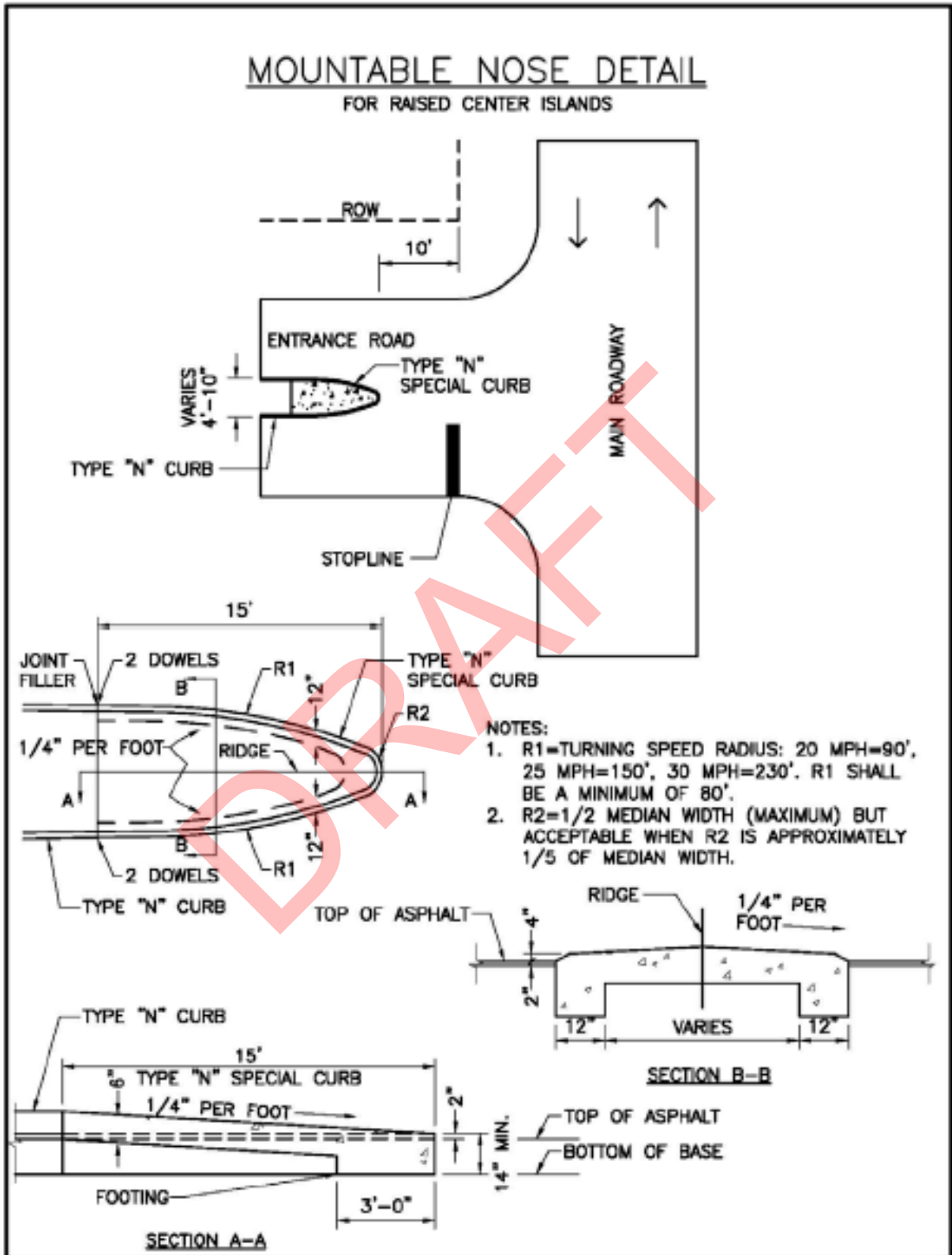

DRAFT



## JACK & BORE DETAIL

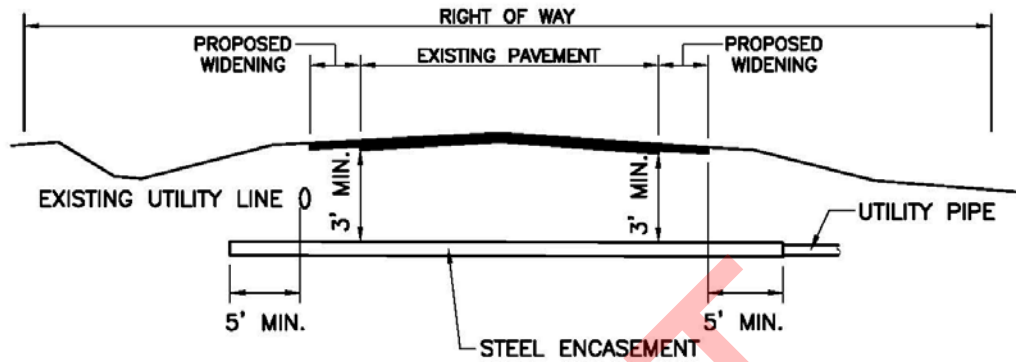

**NOTES:**

1. CASING SHOULD EXTEND AT LEAST 5' BEYOND EXISTING UTILITIES OR EDGE OF PAVEMENT, WHICHEVER IS GREATER.
2. IF WIDENING PLANS EXIST FOR THE ROADWAY TO BE BORED, ADDITIONAL CASING LENGTH MAY BE REQUIRED.
3. SPECIFIC INFORMATION ON BORING UNDER ROADWAYS IS FOUND IN SECTION 4.5.2.2.5 OF THE PUBLIC WORKS DESIGN AND CONSTRUCTION MANUAL.

### ENCASEMENT SIZING WATER AND SANITARY SEWER

CARRIER PIPE		SPACER	STEEL ENCASEMENT	
NOMINAL PIPE DIAMETER	STANDARD PIPE BELL O.D.	CASING SPACER BAND WIDTH	MINIMUM CASING THICKNESS	MINIMUM CASING DIAMETER
4	6.40	8	0.25	14
6	8.60	8	0.25	16
8	11.16	8	0.25	18
10	13.25	8	0.25	20
12	15.22	8	0.25	22
14	17.73	12	0.25	24
16	19.86	12	0.3125	26
18	22.16	12	0.3125	30
20	24.28	12	0.3125	32
24	28.50	12	0.3125	36
30	34.95	12	0.5	42
36	41.37	12	0.5	48

ALL SIZES INDICATED ARE IN INCHES.

\*CASING DIAMETERS BASED ON BEING A MINIMUM OF 6 INCHES GREATER THAN THE OUTER DIAMETER OF THE JOINT BELL TO THE NEAREST EVEN SIZE

DRAFT

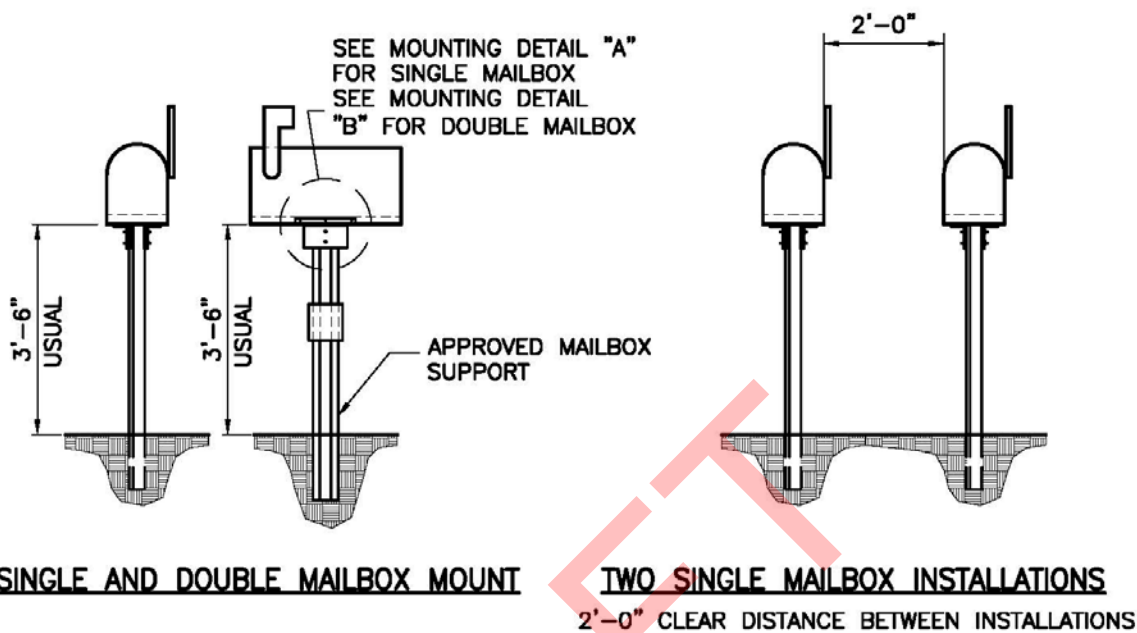
**MAILBOX DETAILS****GENERAL NOTES**

1. BOLTS, NUTS, WASHERS AND OTHER MISCELLANEOUS HARDWARE SHALL BE GALVANIZED IN ACCORDANCE TO ASTM DESIGNATIONS: A-153, CLASS C OR D, OR B-454, CLASS 40. ALL BOLTS SHALL MEET ASTM DESIGNATION: A-307.
2. FOUNDATION AND POST MUST BE DRIVEN PLUMB. RECOMMENDED PROCEDURE IS TO DRIVE POST OR FOUNDATION ABOUT 10-12 INCHES, STOP AND CHECK FOR STRAIGHTNESS, FRONT TO BACK, SIDE TO SIDE. MAKE ADJUSTMENTS, CONTINUE TO DRIVE AN ADDITIONAL 10-12 INCHES, REPEAT CHECK, AND MAKE FINAL ADJUSTMENTS, COMPLETE INSTALLATION.
3. HARDWARE FOR MOUNTING MAILBOXES TO SUPPORT/FOUNDATION FURNISHED BY FORESIGHT PRODUCTS, INC., 6430 EAST 49TH DRIVE, COMMERCE CITY, CO. 80022, 1-800-325-5360 OR EQUIVALENT MAY BE USED WHEN APPROVED BY ENGINEER.
4. ANY SUPPORT OR FOUNDATION ON THESE STANDARDS MAY BE USED FOR MOUNTING SINGLE OR DOUBLE MAILBOXES.
5. ALL MAILBOXES MUST BE MANUFACTURED IN ACCORDANCE WITH U.S. POSTAL SYSTEM SPECIFICATIONS.
6. BOX NUMBERS (AND STREET NAMES WHERE REQUIRED BY THE POSTAL SERVICE) SHALL BE REQUIRED. NUMBERS AND LETTERS SHALL BE IN A COLOR CONTRASTING THE BOX COLOR AND SHALL BE NEAT, 1" MINIMUM IN HEIGHT. BOX NUMBERS SHALL BE LOCATED ON THE SIDE OF THE BOX VISIBLE TO THE CARRIER'S REGULAR APPROACH AND ON THE FRONT OF THE BOX IF REQUIRED BY THE LOCAL LETTER CARRIER.
7. FOR CLARITY, ONLY ONE PROPRIETARY MAILBOX FOUNDATION AND SUPPORT ARE SHOWN, FORESIGHT PRODUCTS INC. OTHER PRODUCTS, SUCH AS NEX MAILBOX SYSTEM, MAY BE USED. ALL PROPRIETARY PRODUCTS SUPPLIED MUST BE CRASH TESTED IN ACCORDANCE WITH NCHRP REPORT 350 AND BE INSTALLED IN ACCORDANCE WITH THE CRASH TESTED CONDITIONS AND THE MANUFACTURER'S RECOMMENDATION.

DRAFT

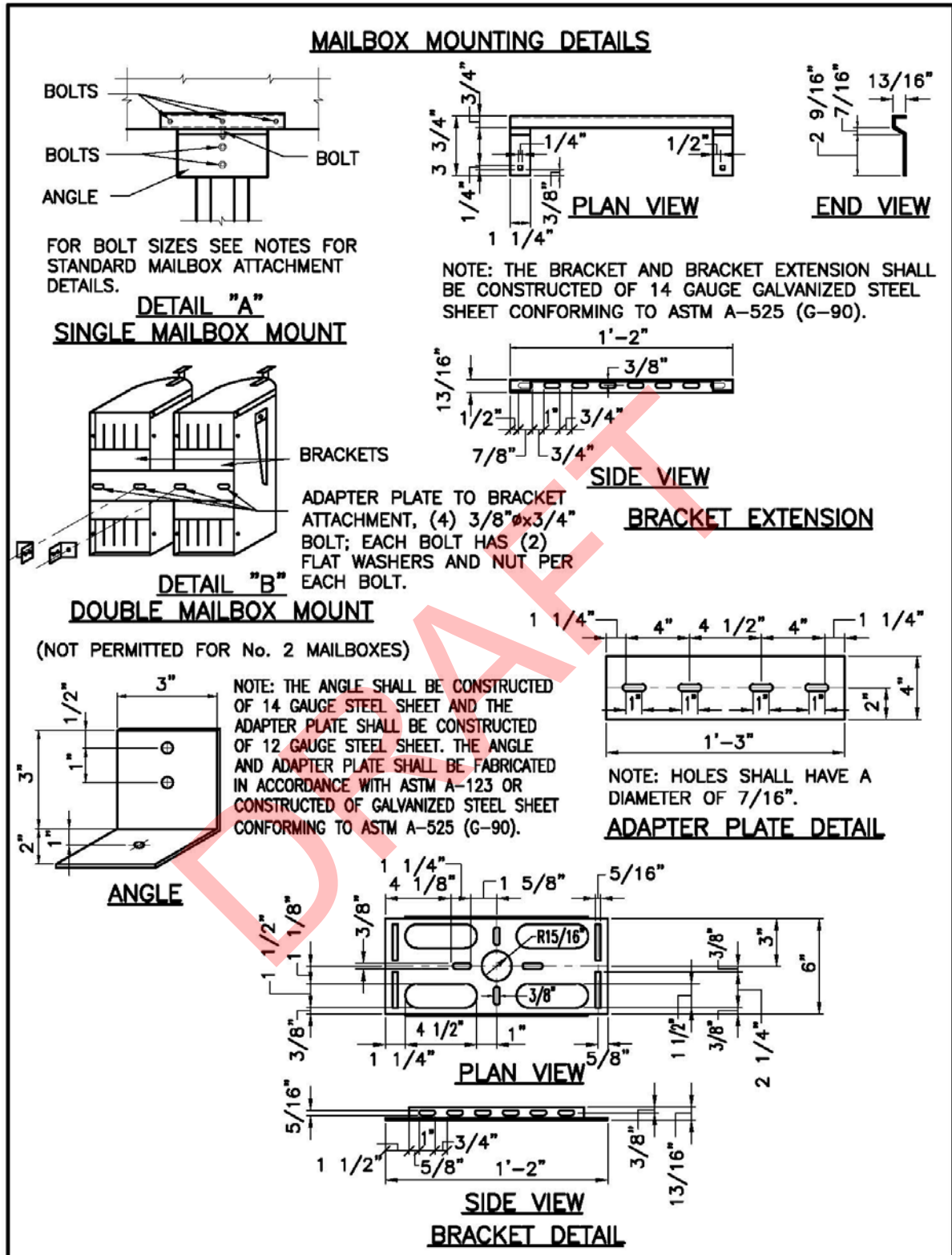

DRAFT

**MAILBOX ATTACHMENT DETAILS**

**BRACKET TO MAILBOX ATTACHMENT:**  
 (6) 3/16"Øx3/4" BOLT W/(2) FLAT WASHERS AND NUT PER EACH BOLT.

**ANGLE TO BRACKET ATTACHMENT:**  
 (2) 3/8"Øx3/4" BOLT W/(2) FLAT WASHERS, LOCK WASHER AND NUT PER EACH BOLT.

**ANGLE TO MAILBOX SUPPORT ATTACHMENT:**  
 (2) 3/8"Øx2 1/2" BOLT W/(2) FLAT WASHERS, LOCK WASHER AND NUT PER EACH BOLT.

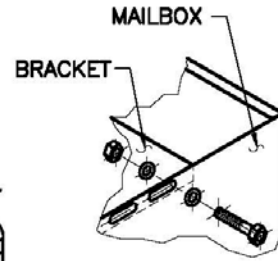

NOTE: BRACKET MAY BE INSTALLED WITH EDGE DOWN ON SIDE NO.1 MAILBOXES ONLY.

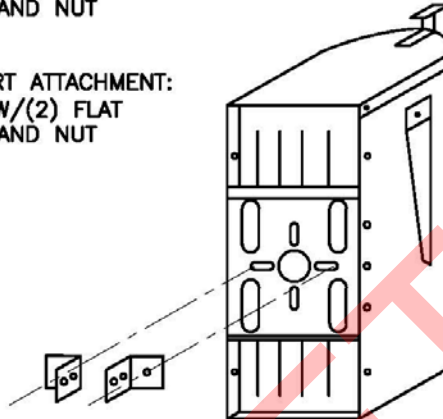

**SIZE NO. 1 MAILBOX**

**STANDARD MAILBOX ATTACHMENT DETAILS**

**BRACKET TO MAILBOX ATTACHMENT:**  
 (6) 3/16"Øx3/4" BOLT W/(2) FLAT WASHERS AND NUT PER EACH BOLT.

**BRACKET TO BRACKET EXTENSION ATTACHMENT:**  
 (2) 3/16"Øx3/4" CARRIAGE BOLT W/ FLAT WASHER, LOCK WASHER AND NUT PER BOLT (4 BOLTS REQUIRED IF (2) BRACKET EXTENSIONS ARE USED).

**ANGLE TO BRACKET ATTACHMENT:**  
 (2) 3/8"Øx3/4" BOLT W/(2) FLAT WASHERS, LOCK WASHER AND NUT PER EACH BOLT.

**ANGLE TO MAILBOX SUPPORT ATTACHMENT:**  
 (2) 3/16"Øx2 1/2" BOLT W/(2) FLAT WASHERS, LOCK WASHER AND NUT PER EACH BOLT.

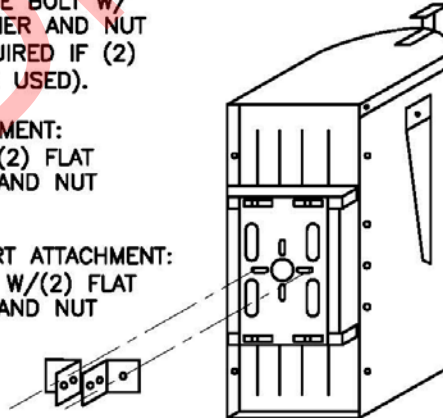
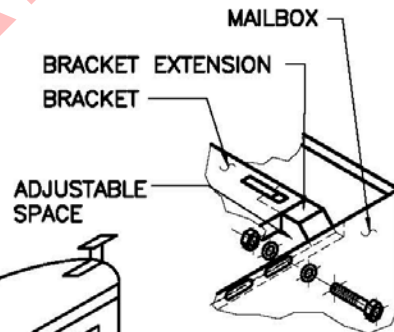

**SIZE NO. 2 AND NO. 3 MAILBOX**

**STANDARD MAILBOX ATTACHMENT DETAILS**

DRAFT



**MAILBOX SUPPORT DETAILS**

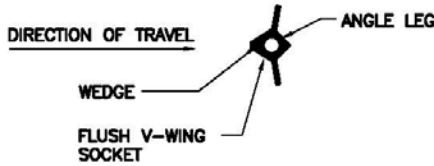
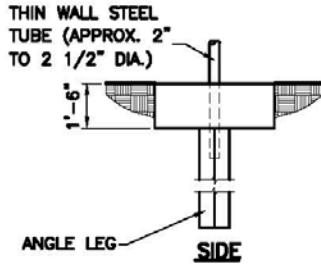
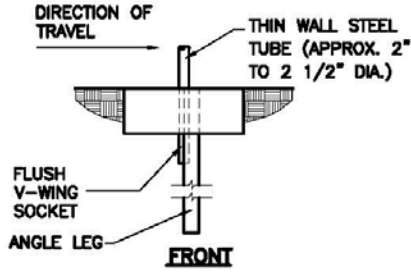

**TYPE 1 SUPPORT/FOUNDATION  
THIN WALL STEEL TUBE W/  
V-LOC ANCHORAGE**

NOTE: THE FORMED TUBE SUPPORT FRAME FOR THE TYPE 1 MAILBOX SUPPORT SYSTEM SHALL BE MANUFACTURED BY FORESIGHT PRODUCTS INC. OR AN APPROVED EQUIVALENT.

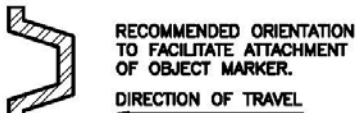
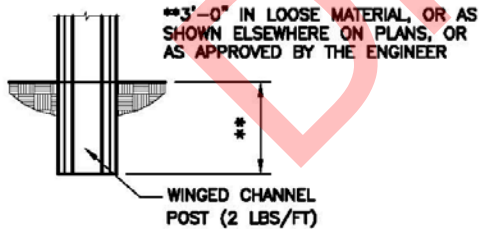

**DELINEATOR POST 2 LBS/FT.**

WINGED CHANNEL POST SHALL CONFORM TO THE REQUIREMENTS OF THE ALDOT SPECIFICATIONS.

**TYPE 3 SUPPORT/FOUNDATION  
DELINEATOR POST**

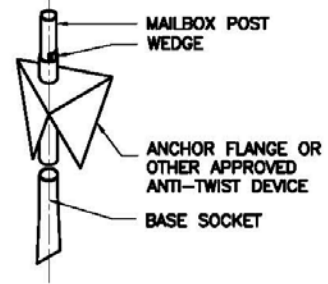
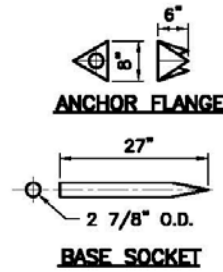

**NOTES FOR TYPE 2 SUPPORT/FOUNDATION**

1. THE BASE SOCKET IS FORMED FROM 2 7/8" O.D. x 12 GAUGE THICKNESS GALVANIZED PIPE.
2. THE ANCHOR FLANGE IS FORMED FROM 12 GAUGE THICKNESS GALVANIZED STEEL MADE TO ASTM A-525. ONLY NEEDED FOR SOFT SOILS AS DETERMINED BY THE ENGINEER.
3. THE WEDGE IS FORMED FROM 11 GAUGE THICKNESS GALVANIZED STEEL MADE TO ASTM A-525.
4. THE MAILBOX POST IS 2 3/8" O.D. x 0.095" THIN WALL STEEL TUBING.
5. STEEL SUPPORT FOUNDATION UNIT SHALL BE MADE FROM NEW MATERIAL AND SHALL BE CORROSION RESISTANT. THE UNIT SHALL BE GALVANIZED IN ACCORDANCE WITH ASTM DESIGNATION A-123, A-525, G-90 OR BETTER. IN ADDITION, STEEL MEMBERS OF THE SUPPORT THAT ARE IN DIRECT CONTACT WITH EARTH MUST BE GALVANIZED TO ASTM DESIGNATION G-90 AND COATED WITH ONE MILL OF CLEAR APPROVED COATING, OR GALVANIZED IN ACCORDANCE WITH ASTM DESIGNATION A-123.

**TYPE 2 SUPPORT/FOUNDATION  
THIN WALL STEEL TUBE W/ ANCHOR FLANGE**

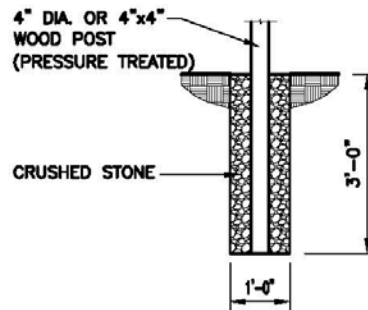

**TYPE 4 SUPPORT/FOUNDATION  
PRESSURE TREATED WOOD POST**

DRAFT

**APPENDIX 4C**  
**REQUEST FOR SIDEWALK CONSTRUCTION FORM**

DRAFT

DRAFT

**Request for Sidewalk Construction Form**  
**City of Phenix City**  
**Engineering and Public Works**  
**1206 7<sup>th</sup> Avenue, Second Floor**  
**Phenix City, Alabama 36867**  
**(334) 448-2760**

Please complete the following information:

Development Name: \_\_\_\_\_

Name: \_\_\_\_\_

Address: \_\_\_\_\_

Daytime Phone: \_\_\_\_\_

Email (optional): \_\_\_\_\_

Other interested parties (Attach additional sheets if necessary for names of all interested parties):

<u>Name</u>	<u>Address</u>	<u>Name</u>	<u>Address</u>
_____	_____	_____	_____
_____	_____	_____	_____
_____	_____	_____	_____
_____	_____	_____	_____

I (or we) request that a sidewalk be constructed on \_\_\_\_\_  
 from \_\_\_\_\_ to \_\_\_\_\_  
 for the following reason(s): \_\_\_\_\_

Provide a map showing the approximate location of the requested sidewalk.

Signature: \_\_\_\_\_ Date: \_\_\_\_\_

<b><i>THIS SECTION FOR OFFICIAL USE ONLY</i></b>		
<b><u>Evaluation</u></b>	<b><u>Determination</u></b>	<b><u>By/Date</u></b>
Available ROW or Easement	_____	_____
Terrain	_____	_____
Existing Obstructions	_____	_____
Existing Trees and Impact	_____	_____
Drainage Conditions	_____	_____
Adjacent Sidewalk/Connectivity	_____	_____
Cost Estimate	_____	_____
Recommendation	_____	_____

DRAFT

**APPENDIX 4D**  
**PERMIT TO CONSTRUCT A TURNOUT TO**  
**PROVIDE ACCESS TO A CITY STREET (RESIDENTIAL)**

DRAFT

DRAFT



**City of Phenix City Engineering and Public Works Department**

**Permit to Construct a Turnout to  
Provide Access to a City Street  
(Residential)**

**Remit to: P.O. Drawer 279, 1206 7<sup>th</sup> Avenue, Phenix City, AL 36867, (334) 448-2760**

Name of Applicant \_\_\_\_\_

Mailing Address \_\_\_\_\_

City \_\_\_\_\_ State \_\_\_\_\_ Zip Code \_\_\_\_\_

Telephone Number \_\_\_\_\_

Address of Proposed Turnout \_\_\_\_\_

Description of Work \_\_\_\_\_

Office Use Only	
Permit Number	
Date Received	
Date Approved	

The applicant hereby request permission from the City of Phenix City Engineering Department to construct a turnout to the above named City Street. The applicant agrees that approval of this request is subject to revocation by the Engineering Department and subject to the following terms and conditions:

1. The applicant agrees to comply with the current policy, specifications, and standard drawings as set forth by the Phenix City Engineering Department. Information is available at the above remittance address.
2. The applicant agrees to contact the Phenix City Engineering Department for a site evaluation before work on said driveway begins and a pre-poured framing inspection.
3. The applicant is not permitted to use any portion of the City right-of-way for any purpose other than construction and maintenance of the proposed turnout. Structures, signs, trees/shrubs, or any other right-of-way encroachment not described above and /or shown on an attached drawing and approved as a part of this permit are prohibited.
4. The applicant agrees to maintain any drainage structures installed or constructed as a part of this permit and keep the same cleaned out and functioning properly at all times. The City will only maintain that portion of the turnout that ties in with the street that may be necessary due to modifications to the roadway.
5. The applicant shall be responsible for locating any underground utilities that may be in conflict with the proposed work. Any damages that occur to existing utilities, existing drainage structures, or the existing street surface will be the sole responsibility of the applicant. In the case where City forces are installing a pipe and fill for the turnout, the applicant's responsibility is waived for that portion of the work completed by City forces.
6. The applicant agrees that the proposed driveway shall not be constructed above any existing water and/or sanitary sewer services and will provide a minimum horizontal clearance of 5 feet between driveway and said services. This requirement is only for water and sanitary sewer services on which the City of Phenix City would perform repairs such as water services from the main to the meter and sanitary services under street pavement.
7. The applicant is responsible for conforming to the regulations of the Environmental Protection Agency (EPA) and the Alabama Department of Environmental Management (ADEM) for the proposed work. This also applies to any hazardous materials encountered during the construction of the turnout.
8. The applicant shall not make any additions or modifications to the turnout or surrounding right-of-way without obtaining a new permit from the Phenix City Engineering Department. The applicant also agrees that the City of Phenix City or its contractors have the right to remove and/or reconstruct the turnout if it becomes necessary without any compensation to the applicant.
9. The turnout and related work covered by this permit shall be completed within one year from the date of application or the permit becomes null and void. Once work has begun it shall be pursued in a continuous and diligent manner until completion.

Signed \_\_\_\_\_  
Applicant Date

Recommended for Approval:

APPROVED:

\_\_\_\_\_  
Authorized Representative Title Date

\_\_\_\_\_  
City Engineer

\_\_\_\_\_  
Date

DRAFT

PROFILE SECTION

(NOT TO SCALE)

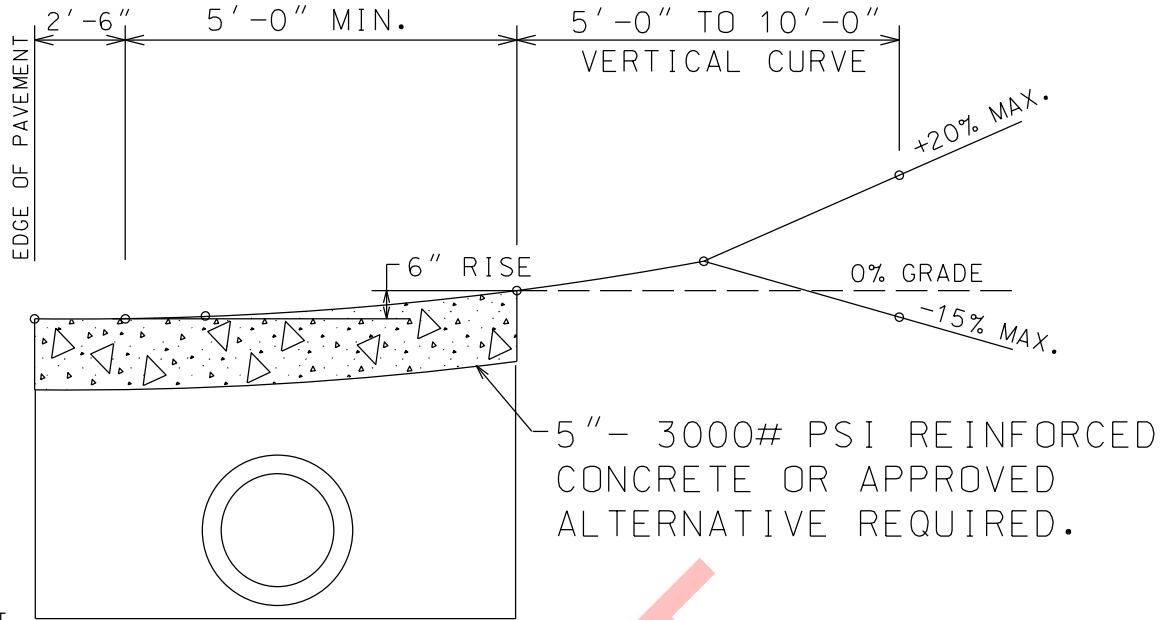

SLOPED PAVED HEADWALL OR FLARE END SECTIONS REQ'D AT EACH END ALTERNATIVE TYPES OF HEADWALLS MUST HAVE APPROVAL OF ENGR. DEPT. SEE ALABAMA DEPT. OF TRANSPORTATION SPC. DWG. FE-619 (FLARED END SECT) SPC. DWG. HW 614-B (SLOPED PAVED)

5" - 3000# PSI REINFORCED CONCRETE OR APPROVED ALTERNATIVE REQUIRED.

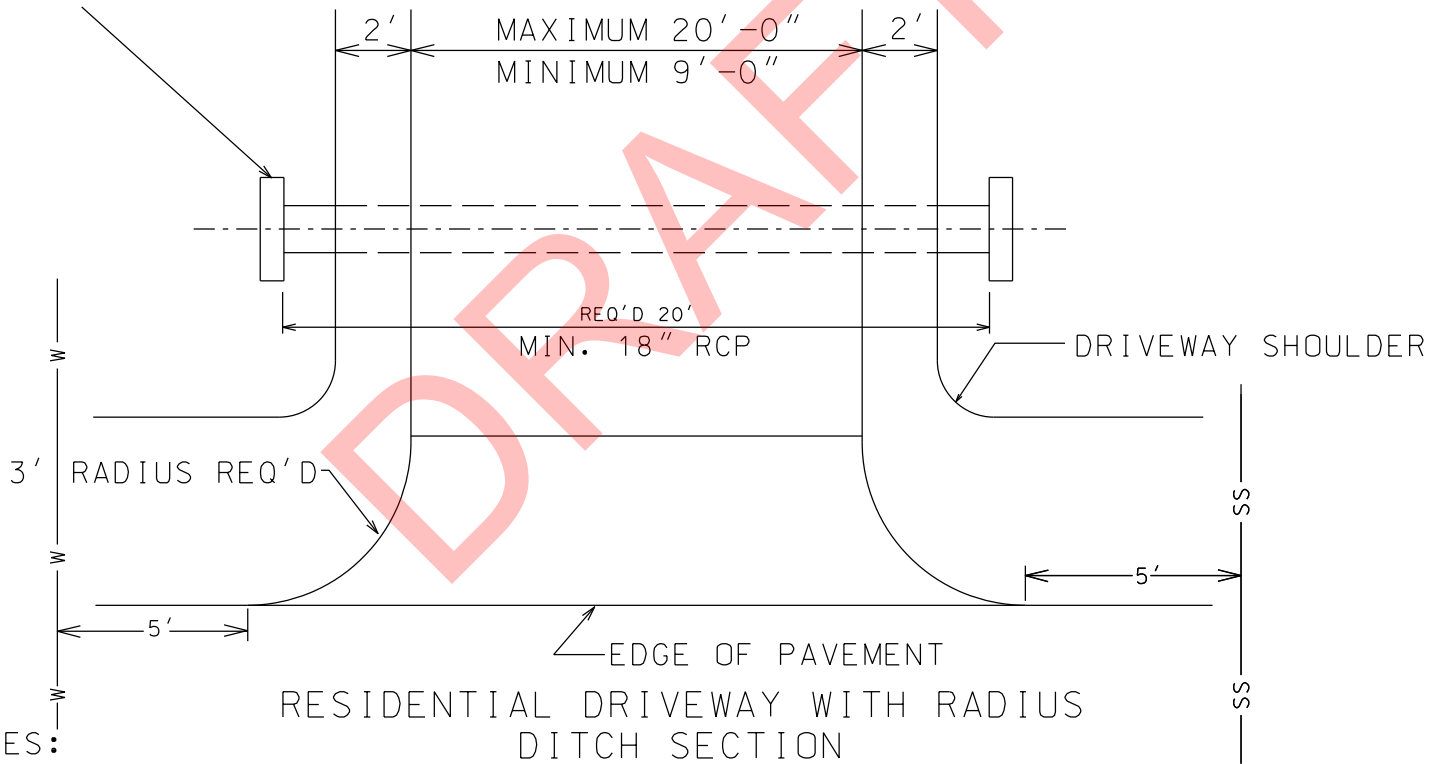

RESIDENTIAL DRIVEWAY WITH RADIUS DITCH SECTION

NOTES:

- DRIVEWAY SHALL BE CONSTRUCTED SO THAT STORM WATER DOES NOT ENTER OR EXIT THE ROADWAY.
- EXISTING CURB & GUTTER SHALL BE SAWCUT AND REMOVED AS REQUIRED BY INSPECTOR, TO PREVENT DAMAGE TO EXISTING PAVEMENT AND CURB. ALL EDGES SHALL BE NEAT AND STRAIGHT. EXISTING CONCRETE SHALL BE SCARIFIED TO ENSURE PROPER BONDING.
- A PERMIT IS REQUIRED TO CONSTRUCT A TURNOUT ON CITY RIGHT OF WAY. CONTACT THE PHENIX CITY ENGINEERING DEPARTMENT (448-2760).
- ALL PARTS OF THE DRIVEWAY, INCLUDING THE CURB RADIUS MUST HAVE AT LEAST 5 FEET OF HORIZONTAL CLEARANCE FROM THE EXISTING WATER AND SANITARY SEWER SERVICE LINES. THIS REQUIREMENT IS FOR THE WATER AND SANITARY SEWER SERVICES ON WHICH THE CITY OF PHENIX CITY WOULD PERFORM REPAIRS SUCH AS WATER SERVICES FROM THE MAIN TO THE METER AND SANITARY SERVICES UNDER THE STREET PAVEMENT.
- LOCATE ALL UTILITIES PRIOR TO BEGINNING WORK. CALL ALA. LINE LOC. CENTER (1-800-292-8525) AND P.C. UTILITIES (448-2902).

DETAILS FOR RESIDENTIAL TURNOUT (RURAL SECTION) RADIUS

PHENIX CITY ENGINEERING DEPT.  
1111 BROAD ST., BLDG. B  
PHENIX CITY, ALABAMA 36867

DWG. NO.:	DATE:	BY:
TO-100 B	12-6-93	BQ
SCALE:	REVISIONS:	
N.T.S.	11-05-14	MLM
	2-09-21	ABT

DRAFT

PROFILE SECTION  
(NOT TO SCALE)

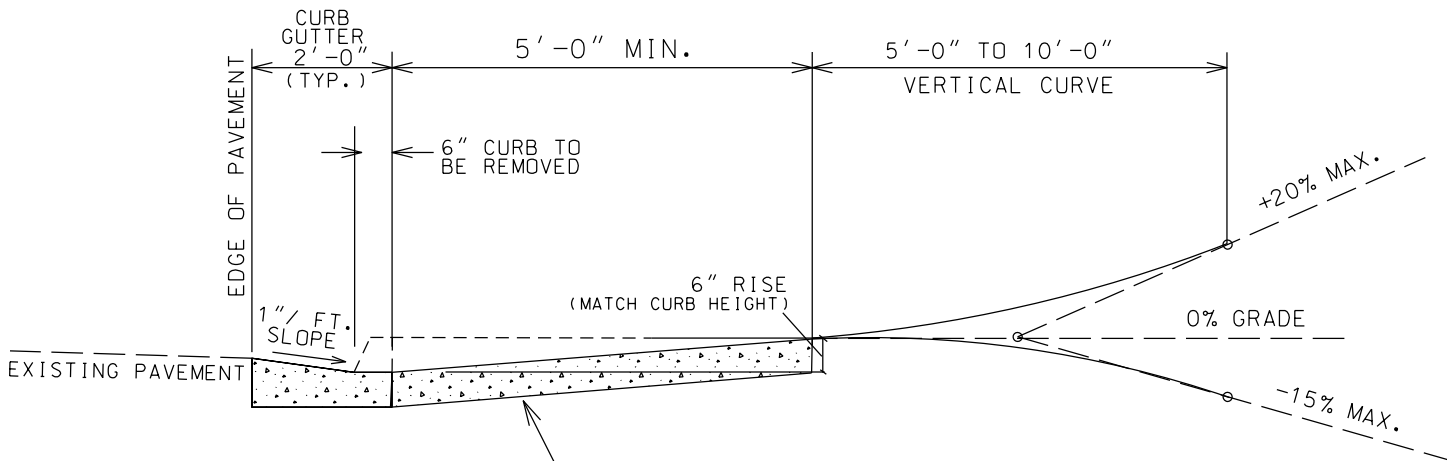

NOTE: A MINIMUM OF FIVE (5) FEET MUST BE MAINTAINED BETWEEN THE DRIVEWAY (INCLUDING THE TURNOUT RADIUS) AND THE NEAREST POINT OF ANY SEWER SERVICE OR WATER SERVICE. DRIVEWAY TURNOUTS SHALL NOT DIRECTLY ABUT ANY STORM INLET.

5" - 3000# PSI REINFORCED CONCRETE OR APPROVED ALTERNATIVE REQUIRED.

PLAN VIEW  
(NOT TO SCALE)

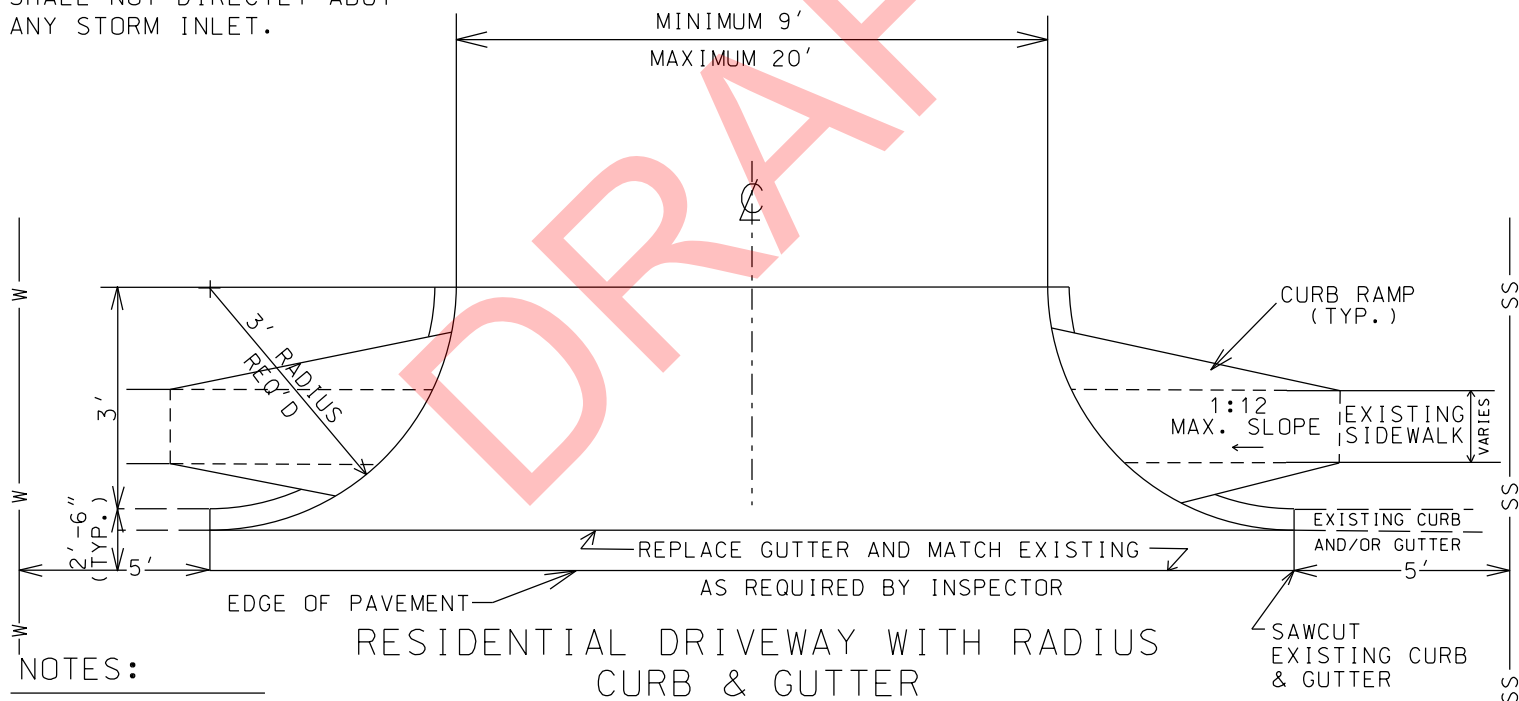

NOTES:

- DRIVEWAY SHALL BE CONSTRUCTED SO THAT STORM WATER DOES NOT ENTER OR EXIT THE ROADWAY.
- EXISTING CURB & GUTTER SHALL BE SAWCUT AND REMOVED AS REQUIRED BY INSPECTOR, TO PREVENT DAMAGE TO EXISTING PAVEMENT AND CURB. ALL EDGES SHALL BE NEAT AND STRAIGHT. EXISTING CONCRETE SHALL BE SCARIFIED TO ENSURE PROPER BONDING.
- A PERMIT IS REQUIRED TO CONSTRUCT A TURNOUT ON CITY RIGHT OF WAY. CONTACT THE PHENIX CITY ENGINEERING DEPARTMENT (448-2760).
- ALL PARTS OF THE DRIVEWAY, INCLUDING THE CURB RADIUS MUST HAVE AT LEAST 5 FEET OF HORIZONTAL CLEARANCE FROM THE EXISTING WATER AND SANITARY SEWER SERVICE LINES. THIS REQUIREMENT IS FOR THE WATER AND SANITARY SEWER SERVICES ON WHICH THE CITY OF PHENIX CITY WOULD PERFORM REPAIRS SUCH AS WATER SERVICES FROM THE MAIN TO THE METER AND SANITARY SERVICES UNDER THE STREET PAVEMENT.
- LOCATE ALL UTILITIES PRIOR TO BEGINNING WORK. CALL ALA. LINE LOC. CENTER (1-800-292-8525) AND P.C. UTILITIES (448-2902).

DETAILS FOR RESIDENTIAL TURNOUT  
(URBAN SECTION) RADIUS

PHENIX CITY ENGINEERING DEPT.  
1111 BROAD ST., BLDG. B  
PHENIX CITY, ALABAMA 36867

DWG. NO.:	DATE:	BY:
TO-100 A	12-6-93	BQ
SCALE:	REVISIONS:	
N.T.S.	11-05-14	MLM
	2-09-21	ABT

DRAFT

**APPENDIX 4E**  
**PERMIT TO CONSTRUCT A TURNOUT TO  
PROVIDE ACCESS TO A CITY STREET (COMMERCIAL)**

DRAFT

DRAFT



### City of Phenix City Engineering and Public Works Department

### Permit to Construct a Turnout to Provide Access to a City Street (Commercial)

Remit to: P.O. Drawer 279, 1206 7<sup>th</sup> Avenue, Phenix City, AL 36867, (334) 448-2760

Name of Applicant \_\_\_\_\_

Mailing Address \_\_\_\_\_

City \_\_\_\_\_ State \_\_\_\_\_ Zip Code \_\_\_\_\_

Telephone Number \_\_\_\_\_

Office Use Only	
Permit Number	
Date Received	
Date Approved	

Address of Proposed Turnout \_\_\_\_\_

Description of Work Shown on the Attached Drawing (may require stamp by a licensed engineer if conditions warrant)

\_\_\_\_\_

The applicant hereby request permission from the City of Phenix City Engineering Department to construct a turnout to the above named City Street. The applicant agrees that approval of this request is subject to revocation by the Engineering Department and subject to the following terms and conditions:

1. The applicant agrees to comply with the current policy, specifications, and standard drawings as set forth by the Phenix City Engineering Department. Information is available at the above remittance address.
2. The applicant agrees to contact the Phenix City Engineering Department for a site evaluation before work on said driveway begins and a pre-poured framing inspection.
3. The applicant is not permitted to use any portion of the City right-of-way for any purpose other than construction and maintenance of the proposed turnout. Structures, signs, trees/shrubs, or any other right-of-way encroachment not described above and /or shown on an attached drawing and approved as a part of this permit are prohibited.
4. The applicant agrees to maintain any drainage structures installed or constructed as a part of this permit and keep the same cleaned out and functioning properly at all times. The City will only maintain that portion of the turnout that ties in with the street that may be necessary due to modifications to the roadway.
5. The applicant shall be responsible for locating any underground utilities that may be in conflict with the proposed work. Any damages that occur to existing utilities, existing drainage structures, or the existing street surface will be the sole responsibility of the applicant. In the case where City forces are installing a pipe and fill for the turnout, the applicant's responsibility is waived for that portion of the work completed by City forces.
6. The applicant agrees that the proposed driveway shall not be constructed above any existing water and/or sanitary sewer services and will provide a minimum horizontal clearance of 5 feet between driveway and said services. This requirement is only for water and sanitary sewer services on which the City of Phenix City would perform repairs such as water services from the main to the meter and sanitary services under street pavement.
7. The applicant is responsible for conforming to the regulations of the Environmental Protection Agency (EPA) and the Alabama Department of Environmental Management (ADEM) for the proposed work. This also applies to any hazardous materials encountered during the construction of the turnout.
8. The applicant shall not make any additions or modifications to the turnout or surrounding right-of-way without obtaining a new permit from the Phenix City Engineering Department. The applicant also agrees that the City of Phenix City or its contractors have the right to remove and/or reconstruct the turnout if it becomes necessary without any compensation to the applicant.
9. The turnout and related work covered by this permit shall be completed within one year from the date of application or the permit becomes null and void. Once work has begun it shall be pursued in a continuous and diligent manner until completion.

Signed \_\_\_\_\_  
Applicant Date

Recommended for Approval:  
\_\_\_\_\_  
Authorized Representative Title Date

APPROVED:  
\_\_\_\_\_  
City Engineer  
\_\_\_\_\_  
Date

DRAFT

PROFILE SECTION

(NOT TO SCALE)

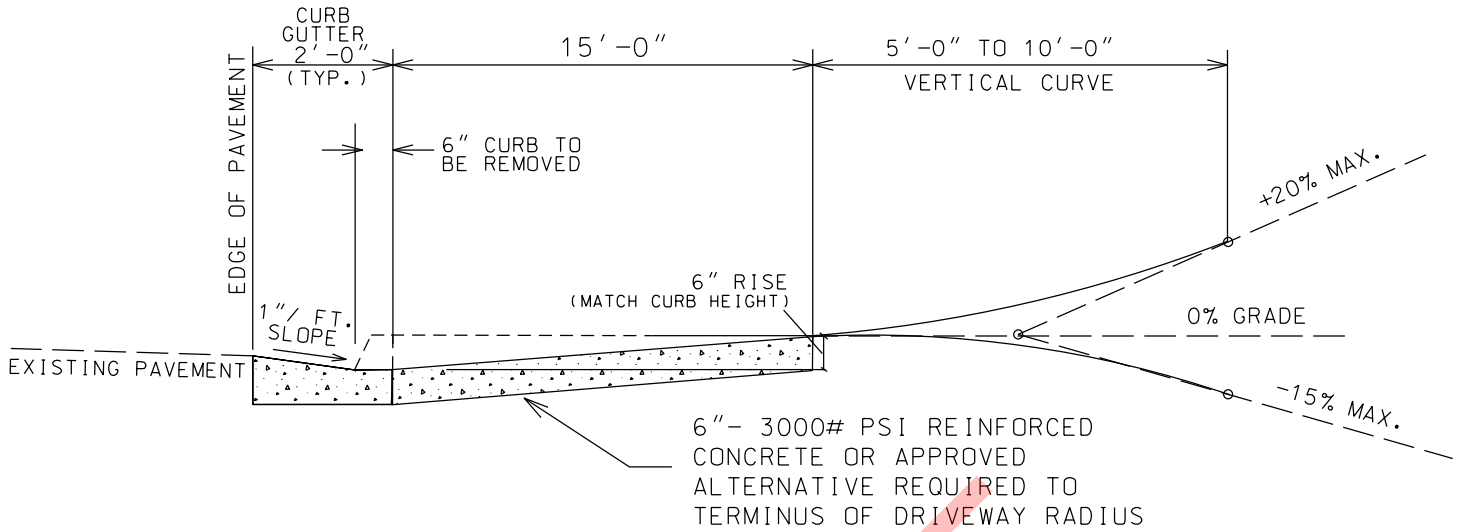

PLAN VIEW  
(NOT TO SCALE)

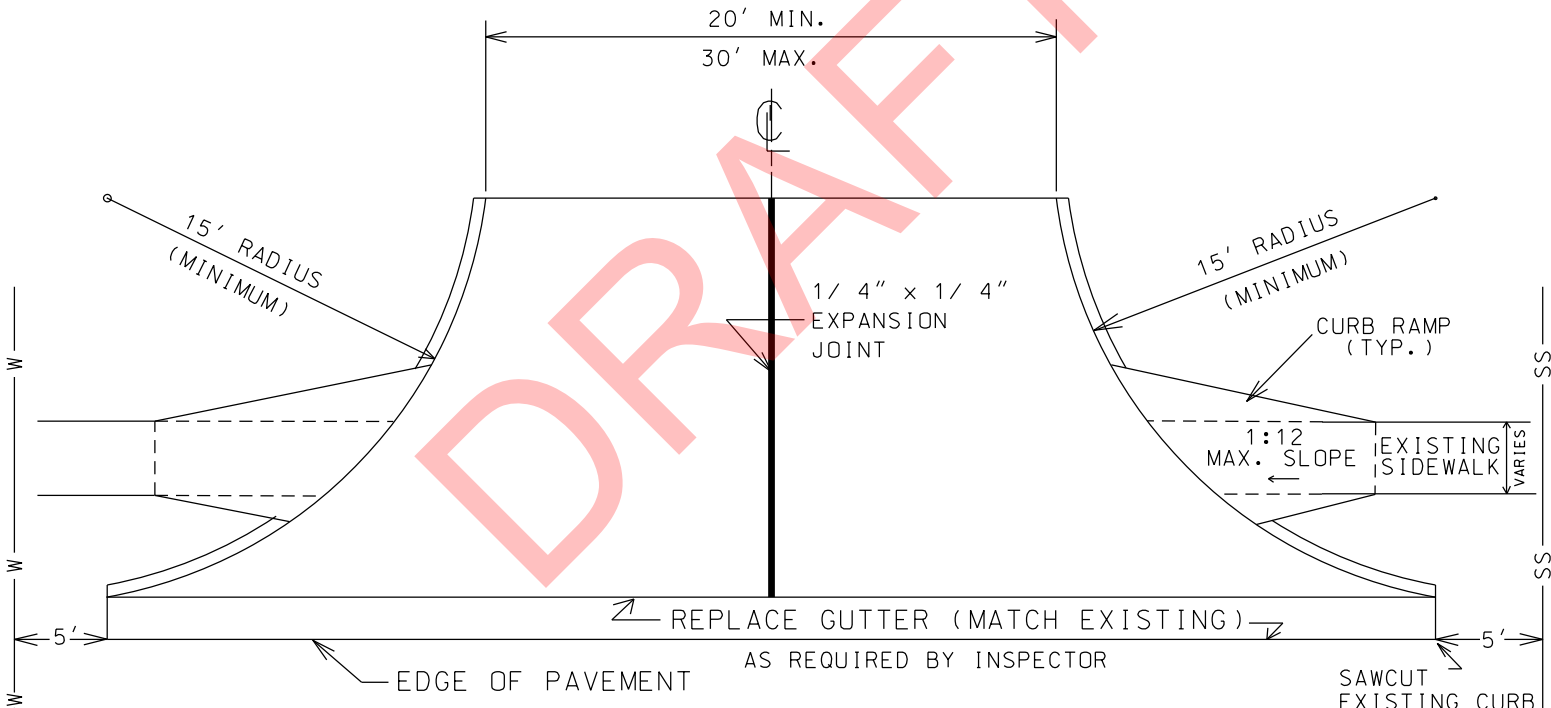

COMMERCIAL DRIVEWAY WITH CURB RADIUS CURB & GUTTER

NOTES:

PROFILE NOT TO SCALE

- DRIVEWAY SHALL BE CONSTRUCTED SO THAT STORM WATER DOES NOT ENTER OR EXIT THE ROADWAY.
- EXISTING CURB & GUTTER SHALL BE SAWCUT AND REMOVED AS REQUIRED BY INSPECTOR, TO PREVENT DAMAGE TO EXISTING PAVEMENT AND CURB. ALL EDGES SHALL BE NEAT AND STRAIGHT. EXISTING CONCRETE SHALL BE SCARIFIED TO ENSURE PROPER BONDING.
- ALL PARTS OF THE DRIVEWAY, INCLUDING THE CURB RADIUS MUST HAVE AT LEAST 5 FEET OF HORIZONTAL CLEARANCE FROM THE EXISTING WATER AND SANITARY SEWER SERVICE LINES. THIS REQUIREMENT IS FOR THE WATER AND SANITARY SEWER SERVICES ON WHICH THE CITY OF PHENIX CITY WOULD PERFORM REPAIRS SUCH AS WATER SERVICES FROM THE MAIN TO THE METER AND SANITARY SERVICES UNDER THE STREET PAVEMENT.
- A PERMIT IS REQUIRED TO CONSTRUCT A TURNOUT ON CITY RIGHT OF WAY. CONTACT THE PHENIX CITY ENGINEERING DEPARTMENT (448-2760).
- LOCATE ALL UTILITIES PRIOR TO BEGINNING WORK. CALL ALA. LINE LOC. CENTER (1-800-292-8525) AND P.C. UTILITIES (448-2902).

DETAILS FOR TURNOUT COMMERCIAL (URBAN SECTION) RADIUS		
PHENIX CITY ENGINEERING DEPT. 1111 BROAD ST., BLDG. B PHENIX CITY, ALABAMA 36867		
DWG. NO.:	DATE:	BY:
TO-100 C	12-6-93	BO
SCALE:	REVISIONS:	
N.T.S.	10-04-06	ABT
	9-29-08	ABT

DRAFT

C PROFILE SECTION

(NOT TO SCALE)

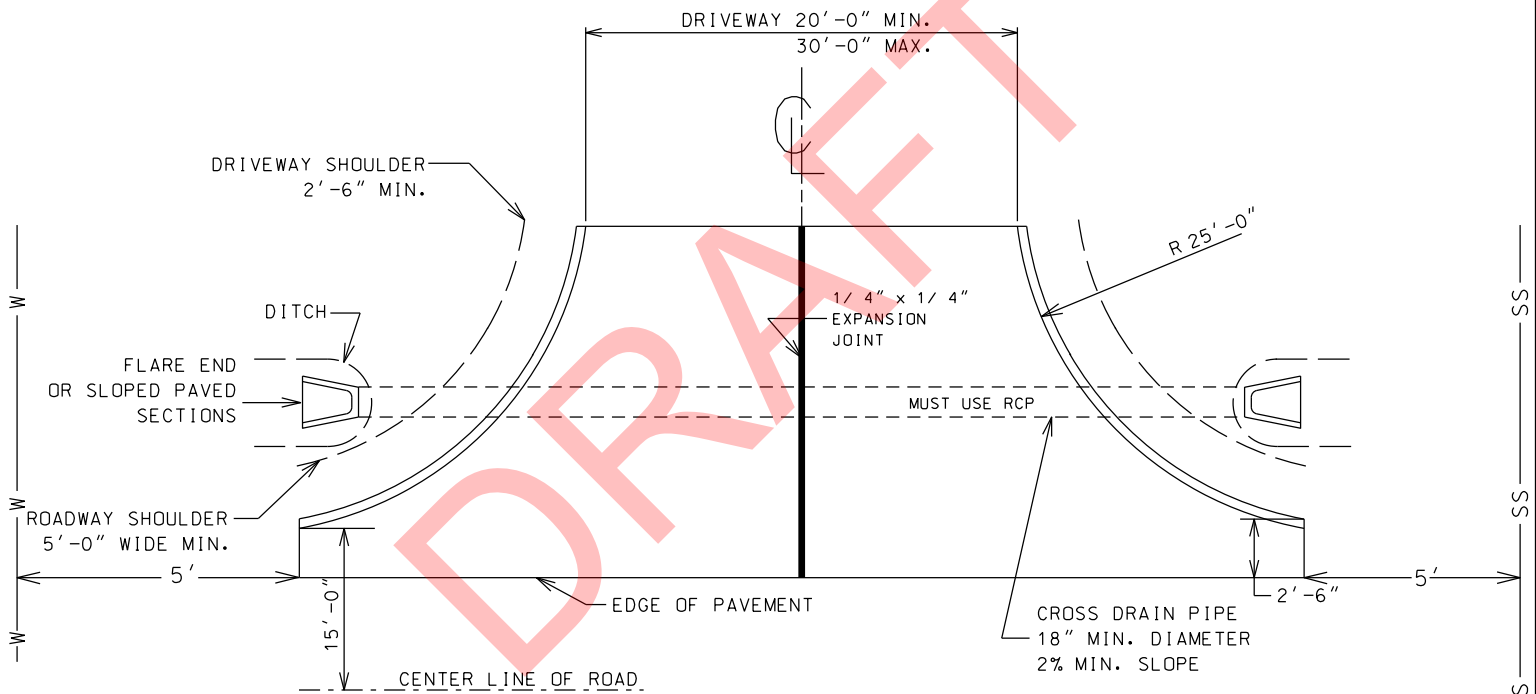
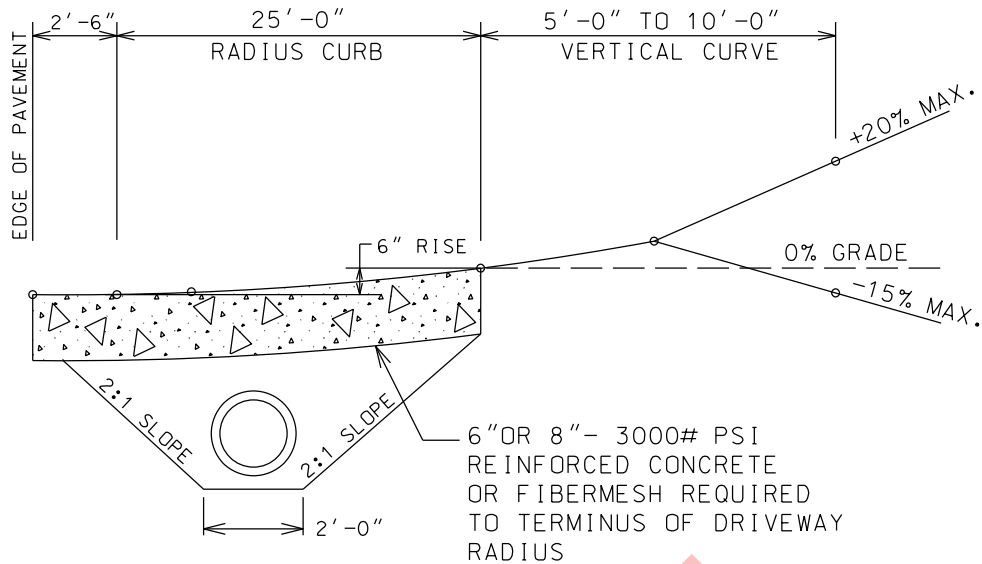

COMMERCIAL DRIVEWAY WITH CURB RADIUS  
DITCH SECTION

NOTES:

PROFILE NOT TO SCALE

- DRIVEWAY SHALL BE CONSTRUCTED SO THAT STORM WATER DOES NOT ENTER OR EXIT THE ROADWAY.
- EXISTING CURB & GUTTER SHALL BE SAWCUT AND REMOVED AS REQUIRED BY INSPECTOR, TO PREVENT DAMAGE TO EXISTING PAVEMENT AND CURB. ALL EDGES SHALL BE NEAT AND STRAIGHT. EXISTING CONCRETE SHALL BE SCARIFIED TO ENSURE PROPER BONDING.
- ALL PARTS OF THE DRIVEWAY, INCLUDING THE CURB RADIUS MUST HAVE AT LEAST 5 FEET OF HORIZONTAL CLEARANCE FROM THE EXISTING WATER AND SANITARY SEWER SERVICE LINES. THIS REQUIREMENT IS FOR THE WATER AND SANITARY SEWER SERVICES ON WHICH THE CITY OF PHENIX CITY WOULD PERFORM REPAIRS SUCH AS WATER SERVICES FROM THE MAIN TO THE METER AND SANITARY SERVICES UNDER THE STREET PAVEMENT.
- A PERMIT IS REQUIRED TO CONSTRUCT A TURNOUT ON CITY RIGHT OF WAY. CONTACT THE PHENIX CITY ENGINEERING DEPARTMENT (448-2760).
- LOCATE ALL UTILITIES PRIOR TO BEGINNING WORK. CALL ALA. LINE LOC. CENTER (1-800-292-8525) AND P.C. UTILITIES (448-2902).

DETAILS FOR COMMERCIAL TURNOUT  
(RURAL SECTION) RADIUS

PHENIX CITY ENGINEERING DEPT.  
1111 BROAD ST., BLDG. B  
PHENIX CITY, ALABAMA 36867

DWG. NO.:	DATE:	BY:
TO-100 D	12-6-93	BQ
SCALE:	REVISIONS:	
N. T. S.	10-04-06	ABT
	9-29-08	ABT

DRAFT

**APPENDIX 4F**  
**LEFT/RIGHT TURN LANE QUICK GUIDE**  
**(ALABAMA DEPARTMENT OF TRANSPORTATION**  
**ACCESS MANAGEMENT MANUAL 2014, APPENDIX D)**

DRAFT

DRAFT



**Source: ALDOT Access Management Manual 2014, Appendix D**  
**All questions regarding the application of this quick guide shall be directed to the City Engineer of the City of Phenix City not to ALDOT.**



## Appendix D Left/Right Turn Lane Quick Guide



**Directions:** The Information contained in this worksheet should be used as a turn lane guide for smaller outparcel developments along ALDOT roadways. Follow steps 1-3 to determine estimated peak hour traffic conditions for the proposed development, and then compare with turn lane traffic volume guides at the bottom of the sheet to determine if a turn lane requirement should be considered. Note the following:

- This sheet does not replace a traffic study (when required) nor does it replace actual development specific turn lane warrant procedures as described in Chapter 4 of the ALDOT Access Management Manual.
- For more information regarding traffic studies see Chapter 3 of the ALDOT Access Management Manual.
- For more information regarding turn lane requirements see Chapter 4 of the ALDOT Access Manual.
- Contact your local ALDOT District staff (refer to Appendix) with any questions regarding information on this sheet.

### Step #1: Trip Generation Estimates – Peak Hour Inbound Only

**Residential Land Uses:**

- Single Family Residential Housing: \_\_\_\_\_ units \* ( 0.63)
- Apartments: \_\_\_\_\_ units \* (0.40)
- Town Homes or Condominiums: \_\_\_\_\_ units \* (0.35)
- Mobile Home Park: \_\_\_\_\_ units \* (0.37)

**Commercial Land Uses:**

- Office Building: ( \_\_\_\_\_ ft<sup>2</sup> floor area/1000) \* (1.36)
- Warehousing: ( \_\_\_\_\_ ft<sup>2</sup> floor area/1000) \* (0.24)
- General Retail (Shopping Center): ( \_\_\_\_\_ ft<sup>2</sup> floor area/1000) \* (1.83)
- Convenience Store w/Gas Pumps: ( \_\_\_\_\_ fueling stations) \* (9.54)
- Pharmacy w/Drive Through: ( \_\_\_\_\_ ft<sup>2</sup> floor area/1000) \* (5.18)
- Drive In Bank: ( \_\_\_\_\_ ft<sup>2</sup> floor area/1000) \* (12.91)
- Sit Down Restaurant: ( \_\_\_\_\_ ft<sup>2</sup> floor area/1000) \* (6.58)
- Fast Food Restaurant w/ Drive Thru: ( \_\_\_\_\_ ft<sup>2</sup> floor area/1000) \*(25.17)

### Step #2: Determine Direction of Approach

Evaluate the existing field conditions and determine the following directions of approach for peak hour inbound site traffic:

\_\_\_\_\_ % Traffic approaching driveway as right turns

\_\_\_\_\_ % Traffic approaching driveway as left turns

### Step #3: Peak Hour Driveway Traffic Volumes Calculation

\_\_\_\_\_ % Rights (from Step #2)\* \_\_\_\_\_ Trips (from Step #1) = \_\_\_\_\_ Peak Hour Right Turns  
 \_\_\_\_\_ % Lefts (from Step #2) \* \_\_\_\_\_ Trips (from Step #1) = \_\_\_\_\_ Peak Hour Left Turns

Note: This assumes 1 site driveway only. If multiple driveways are proposed driveway volumes should be adjusted accordingly. See the ALDOT Access Manual Chapter 4 for guidance.

#### Left Turn Lane Guidelines:

**Roadway Under 6,000 veh/day AADT**

If the peak hour left turns are greater than 40 then a left turn lane is required.

**Roadway Over 6,000 veh/day AADT**

If the peak hour left turns are greater than 30 then a left turn lane is required.

#### Right Turn Lane Guidelines:

**Roadway Under 6,000 veh/day AADT**

If the peak hour right turns are greater than 30 then a right turn lane is required.

**Roadway Over 6,000 veh/day AADT**

If the peak hour right turns are greater than 20 then a right turn lane is required.

The need for a turn lane is not totally absolved when the estimated number of peak hour turns falls below the values shown above. A turn lane or turn lane warrant analysis may still be required at ALDOT's discretion.

*Source: ALDOT Access Management Manual 2014, Appendix D*  
*All questions regarding the application of this quick guide shall be directed to the City Engineer of the City of Phenix City not to ALDOT.*



## Appendix D Left/Right Turn Lane Quick Guide



Note: AADT Data can be found via:

1. Go to ALDOT Home Page at [www.dot.state.al.us](http://www.dot.state.al.us)
2. Under "Bureaus/Divisions/Offices", select "Traffic Planning" from the pick list.
3. Under "Navigation", click on Traffic
4. Then click on Alabama Traffic

The Access Management Manual can be found here:

<https://www.dot.state.al.us/publications/Maintenance/pdf/Permits/AccessManagementManual.pdf>

Traffic Data can be found here:

<https://aldotgis.dot.state.al.us/TDMPublic/>

**APPENDIX 4G**  
**APPLICATION FOR INSTALLATION OF**  
**UNDERGROUND UTILITY PERMIT**

DRAFT

DRAFT

APPLICATION NUMBER: \_\_\_\_\_

<b>APPLICATION FOR INSTALLATION OF UNDERGROUND UTILITY PERMIT</b>  <b>CITY OF PHENIX CITY</b>  <b>DEPARTMENT OF ENGINEERING AND PUBLIC WORKS</b>	
NAME OF APPLICANT:	DATE:
PROJECT TITLE:	
PROJECT START DATE:	PROPOSED DATE OF COMPLETION:
NAME OF PROJECT SUPERVISOR:	
EMERGENCY TELEPHONE NUMBER:	
SUBCONTRACTOR NAME & TELEPHONE NUMBER:	
REASON FOR PERMIT*:	
PROJECT LOCATION:	
WILL PROJECT REQUIRE STREET CLOSURE:    Y / N	
DATE AND TIME OF REQUESTED STREET CLOSURE:	
WILL PROJECT REQUIRE WORK TO BE PERFORMED DURING TIMES OTHER THAN NORMAL BUSINESS HOURS:    Y / N	
PLEASE PROVIDE A BRIEF DESCRIPTION OF THIS WORK AND THE TIME IT WILL COMMENCE:	
NONREFUNDABLE PERMIT APPLICATION FEE (\$30.00) ATTACHED:    Y / N	
COMPLETE CONSTRUCTION PLANS ATTACHED:    Y / N	
MAP OF PROJECT AREA PROVIDED DETAILING PERMITEE'S UTILITIES:    Y / N	
I, _____, AS AUTHORIZED AGENT FOR THE ABOVE NAMED APPLICANT, AGREE TO COMPLY WITH THE CONDITIONS OF THIS PERMIT AS STATED IN ORDINANCE 2010-31, INCLUDING ALL REQUIRED FEES.	

\*ATTACH DRAWINGS AND DESCRIPTION OF WORK TO BE PERFORMED WITH THIS APPLICATION.

DRAFT

<b>FOR OFFICIAL CITY PERSONNEL ONLY:</b>
PERMIT ISSUED: Y / N
STREET CLOSURE APPROVED BY CITY ENGINEER: Y / N
AREA OF DISTURBED PAVEMENT (SQ FT):
INSPECTION FEE (SQ. FT OF DISTURBED PAYMENT * \$.045):
INSPECTION FEE PAID: Y / N
AGE OF PAVEMENT:
RESURFACING FEE:

<b>PAVEMENT RESURFACING FEE SCHEDULE FOR PAVEMENT 0 - 10 YEARS*</b>			
<i>Area of Street Cut (square feet)</i>	<i>Base Cost For Cut</i>	<i>Cost For Streets With Pavement Age 0 to 4 Years</i>	<i>Cost For Streets With Pavement Age 5 to 10 Years</i>
100	\$150	\$450	\$300
200	\$300	\$900	\$600
300	\$450	\$1,350	\$900
400	\$600	\$1,800	\$1,200
500	\$750	\$2,250	\$1,500
600	\$900	\$2,700	\$1,800
700	\$1,050	\$3,150	\$2,100
800	\$1,200	\$3,600	\$2,400
900	\$1,350	\$4,050	\$2,700
1,000	\$1,400	\$4,200	\$2,800
1,500	\$2,400	\$7,200	\$4,800
2,000	\$3,200	\$9,600	\$6,400
2,500	\$4,000	\$12,000	\$8,000
3,000	\$4,800	\$14,400	\$9,600
<b>Over 3,000</b>	<b>\$1.70*(Sq.Ft.)</b>	<b>3*(\$1.70)(Sq.Ft.)</b>	<b>2*(\$1.70)(Sq.Ft.)</b>

\* Pavement resurfacing fee will be tripled for streets that have been constructed, reconstructed, overlaid or have received a seal coat in last 5 years. Conversely fee may be reduced if utility repairs are made in advance of pavement rehabilitation projects or when utility companies perform a complete street overlay.

<b>RESURFACING FEES PER SQUARE FOOT FOR PAVEMENT 11 - 15 YEARS</b>	
<i>Area of Pavement Disturbed (per square foot)</i>	<i>Cost Per Square Foot</i>
1 to 1,000	\$1.50
1,001 to 3,000	\$1.60
Over 3,000	\$1.70

<b>RESURFACING FEES PER SQUARE FOOT FOR PAVEMENT GREATER THAN 15 YEARS</b>	
<i>Area of Pavement Disturbed (per square foot)</i>	<i>Cost Per Square Foot</i>
1 to 1,000	\$0.38
1,001 to 3,000	\$0.40
Over 3,000	\$0.43

DRAFT



**APPENDIX 4H**  
**TRAFFIC SIGN REQUEST FORM (NEW DEVELOPMENT)**

DRAFT

DRAFT

**Traffic Sign Request Form (New Development)**  
**City of Phenix City**  
**Engineering and Public Works**  
**1206 7<sup>th</sup> Avenue, Second Floor**  
**Phenix City, Alabama 36867**  
**(334) 448-2760**

Please complete the following information:

Development Name: \_\_\_\_\_

Contact: \_\_\_\_\_

Address: \_\_\_\_\_

Daytime Phone: \_\_\_\_\_

Email: \_\_\_\_\_

Provide a map (or maps) showing the location of the requested street name signs and regulatory signs for the proposed development. Include notes describing sign sizes, letter sizes, colors and reflectivity. Detail decorative insignia, signs and signposts.

Street Names requested for use in this development:

The Engineering and Public Works Department will review the plan and perform any necessary data collection and analysis to assess the need for the installation of the requested traffic signs. All signs shall be installed in accordance with the Manual on Uniform Traffic Control Devices, latest edition.

Signature: \_\_\_\_\_ Date: \_\_\_\_\_

<b><i>THIS SECTION FOR OFFICIAL USE ONLY</i></b>		
<b><u>Evaluation</u></b>	<b><u>Determination</u></b>	<b><u>By/Date</u></b>
Planning Commission		
Approved Names	_____	_____
Speed Limits	_____	_____
Installation Meets		
MUTCD	_____	_____
Recommendation		

DRAFT

**APPENDIX 4I**  
**TRAFFIC SIGN REQUEST FORM (EXISTING DEVELOPMENT)**

DRAFT

DRAFT

**Traffic Sign Request Form (Existing Development)**  
**City of Phenix City**  
**Engineering and Public Works**  
**1206 7<sup>th</sup> Avenue, Second Floor**  
**Phenix City, Alabama 36867**  
**(334) 448-2760**

Please complete the following information:

Development Name: \_\_\_\_\_

Contact: \_\_\_\_\_

Address: \_\_\_\_\_

Daytime Phone: \_\_\_\_\_

Email: \_\_\_\_\_

Indicate number of signs requested:

\_\_\_\_ Stop Sign      \_\_\_\_ Yield Sign      \_\_\_\_ Speed Limit \_\_\_\_ mph

\_\_\_\_ Dead End      \_\_\_\_ No Outlet      \_\_\_\_ Speed Limit \_\_\_\_ mph

\_\_\_\_ Other: \_\_\_\_\_      Other: \_\_\_\_\_

Indicate number of Street Name Signs requested:

<u>Number of Signs</u>	<u>North/South Street</u>	<u>East/West Street</u>
_____	_____	_____
_____	_____	_____
_____	_____	_____
_____	_____	_____

Provide a map showing the approximate location of the requested signs. Attach as many sheets as necessary. The Engineering and Public Works Department will perform any necessary data collection and analysis to assess the need for the installation of the requested traffic sign. All signs shall be installed in accordance with the Manual on Uniform Traffic Control Devices, latest edition.

Signature: \_\_\_\_\_ Date: \_\_\_\_\_

<b>THIS SECTION FOR OFFICIAL USE ONLY</b>		
<u>Evaluation</u>	<u>Determination</u>	<u>By/Date</u>
Planning Commission	_____	_____
Approved Name	_____	_____
Speed Limit	_____	_____
Installation Meets MUTCD	_____	_____
Cost Estimate	_____	_____
Recommendation	_____	_____

DRAFT



**APPENDIX 4J**  
**DESCRIPTIONS OF STAGE 2 TRAFFIC CALMING MEASURES**

DRAFT

DRAFT

### Descriptions of Stage 2 Traffic Calming Measures

Traffic calming involves two (2) types of devices to influence vehicle operation and driver behavior: 1) Horizontal devices, or street narrowing, such as chicanes, pinch points, traffic circles, and median islands; and 2) Surface Texture, such as pavers or different types of pavement.

#### Horizontal Devices:

##### Chicanes

Chicanes are mid-block curb extensions or concrete bulb-outs that alternate from one side of the street to the other, forming S-shaped curves that force drivers to navigate the roadway at a slower speed.

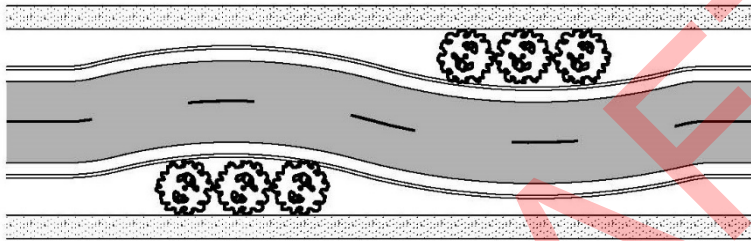

Figure 4J-1: Example of Chicane Without On-Street Parking

Chicanes can also be created by alternating on-street parking, either diagonal or parallel, between one side of the street and the other. Each parking bay can be created either by restriping the roadway or by installing raised, landscaping islands at the ends of each parking bay. This technique is also suitable for use with pairs of off-set T-intersections.

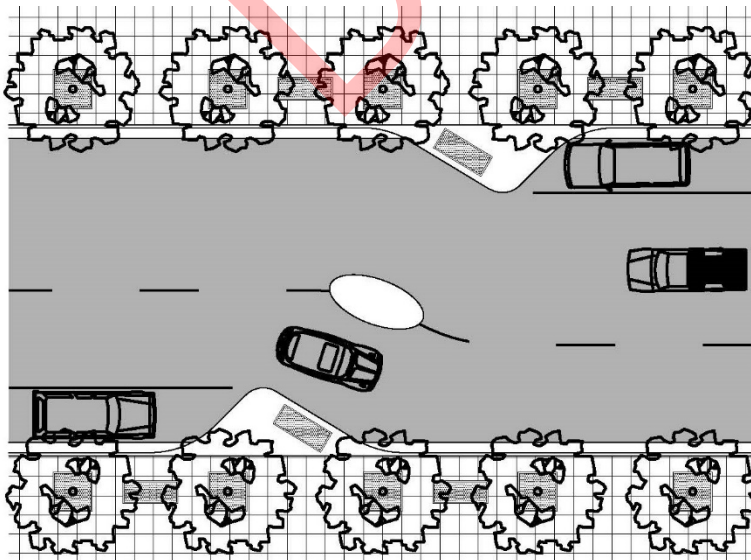

Figure 4J-2: Example of Chicane With On-Street Parking

### Pinch Points

Pinch points are curb extensions at intersections or in mid-block areas that reduce the roadway width from curb to curb. They create a pedestrian-friendly environment by shortening crossing distances for pedestrians. When applied at intersections, they also tighten the curb radii at the corners, reducing the speeds of turning vehicles.

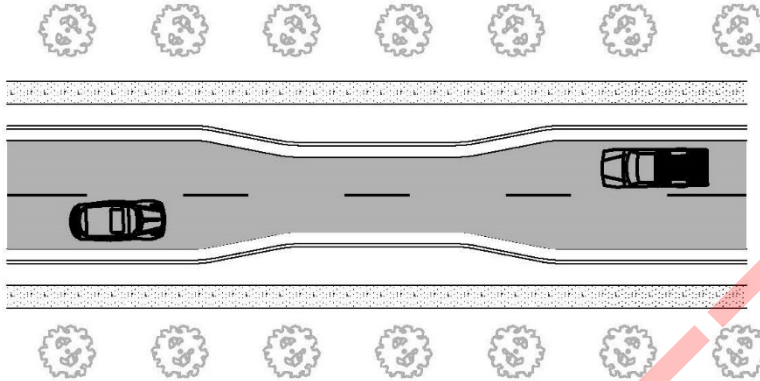

Figure 4J-3: Example of Pinch Point

### Traffic Circles

Traffic circles are raised islands, placed in intersections, around which traffic circulates. Traffic circles, or mini-roundabouts, reduce the number of conflict points in an intersection and physically reduce speeds.

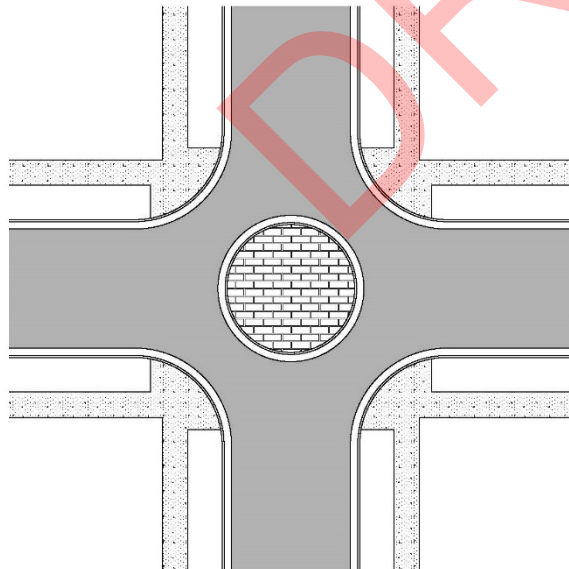

Figure 4J-4: Example of Traffic Circle

## Median Islands

A median island is a raised barrier located along the centerline of a street that narrows the travel lanes at that location. When placed at the entrance to a neighborhood, it can provide positive indication that a driver is entering a residential area. If designed well, median islands can have positive aesthetic value, providing a landscaping opportunity.

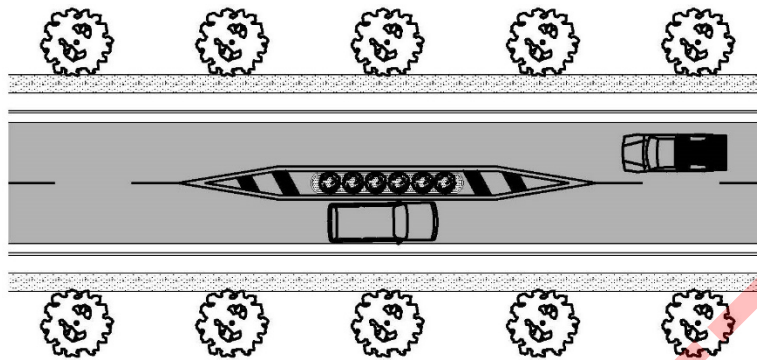

Figure 4J-5: Example of Median Island

Partial or full road closures are often used to address the issue of cut through traffic. Full street closures can include landscaped islands, walls, gates, or bollards or any other type obstruction constructed in existing roadways to prevent the passage of vehicles. Barriers can also be constructed diagonally across an intersection to divert traffic and prohibit the through movement across the intersection.

Partial or half closures are barriers that restrict traffic to one-way travel for a distance approaching or departing an intersection.

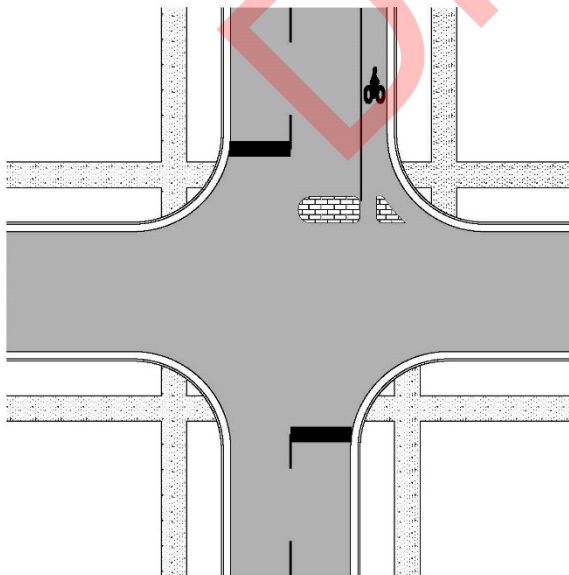
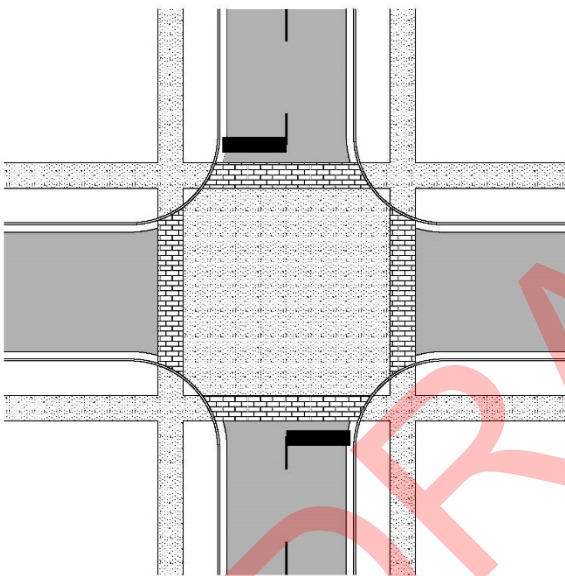

Figure 4J-6: Example of Diverter Island for a Half Road Closure

### Surface Texture:

#### **Textured Pavements / Surface Roughening**

Textured pavements, or surface roughening, are a traffic calming measure consisting of a change in typical roadway surface material with the use of brick, concrete pavers, stamped asphalt/concrete, or rumble strips. This treatment can be used on the entire footprint of an intersection or on individual raised or at-grade crosswalks. A textured treatment has the effect of increasing driver awareness to the idea that vehicles share the space with pedestrians and bicyclists. Textured pavements are also associated with reduced travel speeds. This type of traffic calming measure is useful in areas where the loss of on-street parking would be unacceptable.



*Figure 4J-7: Example of Textured Pavement*

**APPENDIX 4K**  
**TRAFFIC CALMING PETITION PACKAGE**

DRAFT

DRAFT



**Traffic Calming Petition Package**  
**City of Phenix City**  
**Engineering and Public Works**  
**1206 7<sup>th</sup> Avenue, Second Floor**  
**Phenix City, Alabama 36867**  
**(334) 448-2760**

Date:

Applicant Name/Address:

Dear Applicant:

The City of Phenix City has conducted a transportation study of the requested area to evaluate the need for traffic calming techniques due to speeding / cut-through traffic. Based on the City's evaluation, a \_\_\_\_\_ is being considered to be installed at \_\_\_\_\_.

Before this traffic calming measure can be approved, you are required to circulate this petition to all affected property owners within the study area. Each property owner shall indicate their desire to have the traffic calming measure installed.

A positive response must be obtained by sixty-six (66%) percent or more of the total number of properties in the affected area to proceed further with the traffic calming project design and implementation. Please note that only one (1) adult signature per property will be counted. The petition must be returned to the City Engineer within three (3) months of the date of this letter.

If you have any questions, please contact Ms. Angel Moore, City Engineer and Director of Public Works at (334) 448-2760.

Sincerely,

Angel Moore, P.E.  
City Engineer and Director of Public Works

Attachment – Petition for Traffic Calming Measures

DRAFT



DRAFT



DRAFT



DRAFT



## 5.0 GEOTECHNICAL

### 5.1 INTRODUCTION

The purpose of this section of the Manual is to provide guidance on the geotechnical aspects of design and construction of infrastructure within the City's jurisdiction. References to applicable standards and regulations in other publications are provided.

### 5.2 OVERVIEW OF GEOTECHNICAL INVESTIGATIONS

Geotechnical investigations shall be performed in general accordance with this document as well as other City standards and details. Typical geotechnical investigations shall consist of the following tasks: reviewing published geologic and site use data, planning and execution of subsurface exploration, laboratory testing, geotechnical analyses, and presenting conclusions and recommendations in drawing(s) and a written report.

Public data sources that may provide meaningful site information include topographic mapping, aerial photographs, geologic mapping, mine documentation, well records, etc. This information shall be considered when planning subsurface exploration activities.

Regardless of the project details, the subsurface exploration shall be coordinated with the project's Designer(s) to ensure understanding of project details and requirements. Sampling of soil and rock at a project site is most often accomplished through geotechnical borings. Subsurface exploration methods may also include test pits, cone penetrometer soundings and geophysical test methods. For most explorations, geotechnical borings with regular sampling in soil by the standard penetration test (SPT) is satisfactory for characterization of generalized soil conditions. The SPT shall be performed in accordance with ASTM D 1586. Where performed, rock sampling shall be performed in general accordance with ASTM D 2113 using a minimum core diameter of 1.875 inches, or NQ. If ground water is encountered during the investigation, the elevation of the water table shall be documented.

Depths explored and types of samples obtained by selected subsurface exploration techniques shall be considered prior to beginning field activities. Should encountered conditions differ significantly from what was anticipated, supplemental exploration activities may be required.

Laboratory testing shall be performed on representative soil and rock samples. Testing is anticipated to confirm, or allow correction of, visual classifications made at the time of sample collection. Laboratory testing also allows assessment of physical and chemical properties and aids in selection of mechanical properties.

Upon selection of subsurface model parameters, geotechnical analyses shall be conducted to confirm that various stability and performance requirements for planned construction can be achieved. Conclusions shall be supported by engineering analyses.

Results of the subsurface exploration and geotechnical recommendations shall be presented within an engineering report. This engineering report shall include a site plan which denotes planned site features as well as subsurface exploration test sites. Field and laboratory test results shall be clearly presented. Design plans for the project shall incorporate the recommendations and conclusions drawn from the geotechnical investigation. The report of geotechnical investigation shall be made available to all prospective Contractors that may bid on City projects.

## **5.3 EARTHWORK**

The requirements provided below will apply to any earthwork being performed on a City project or a project that will be maintained by the City. This will typically include earthwork (excavation and filling) associated with construction of streets, utilities, detention ponds, parks, and parking lots.

### **5.3.1 Earthwork Investigation**

A geotechnical earthwork investigation shall be performed for new roadways, embankments, and slopes. The intent of an earthwork investigation is to determine the type of materials that will be encountered along the project and to provide stakeholders with subsurface information prior to beginning construction.

An earthwork investigation shall include visual assessment and identification of any wet and/or soft areas. Identified wet/soft surface soils require probing or other subsurface exploration to determine the probable thickness of unstable soil. Unsuitable material is defined as soils that are excessively wet/weak, highly plastic (plasticity index from ASTM D 4318 is greater than 30%), soils with organic content in excess of 2% by volume, or debris/rubble. Delineated unsuitable materials require undercut and replacement.

Geotechnical borings shall generally be drilled every 200 to 400 feet along the approximate centerline of new earthwork. Boring spacing and locations may vary from this general guidance where utilities or other considerations limit reasonable access. If the project involves any earthwork other than for a roadway, boring spacing shall generally be no more than 200 feet apart. Additional guidance for geotechnical investigation of dams is provided in Section 5.5.4 of this Manual.

Borings shall be drilled to depths of at least twice the proposed fill height, at least 10 feet into competent soils (i.e., SPT N values of  $\geq 6$  blows per foot) below finish grades, or to auger refusal. Perform additional field and/or laboratory testing if significant differences in subsurface conditions are suspected between borings or if subsurface cross sections are relevant to evaluations, such as analyzing stability of slopes, estimating settlements of new embankment, etc. Collection of Shelby tube samples may be warranted in soft fine-grained soils to allow for laboratory determinations of shear strength and compressibility characteristics.

Assess shrinkage and/or swell potential for the soil and rock encountered on the project. Sample each soil strata encountered and furnish Unified and/or AASHTO soil classifications.

For investigations of new roadways, collect representative bulk samples within 5 feet of planned subgrades and designated borrow sources. To support pavement design, resilient modulus testing in accordance with AASHTO T 307 may be conducted on a composite sample of anticipated subgrade soils. Alternately, California Bearing Ratio (CBR) tests in accordance with ASTM D 1883 may be performed on representative sample(s), and resilient modulus can be inferred by correlation with laboratory determined CBR.

Identify any areas where the subgrade may require stabilization or undercut/replacement. Where applicable, the Geotechnical Engineer shall recommend the percentage of lime and minimum depth of mixing based on laboratory soil testing results. If bridging with granular soils and geosynthetics is a recommended means of mitigating unstable subgrade, guidance shall be provided by the Geotechnical Engineer.

### **5.3.2 Embankment Fill**

Whether onsite or borrow material is used as new embankment fill, it shall consist of native soil, processed soil, or crushed aggregate that is free of debris, frozen material, or organic matter. Fill soil shall be placed in thin, loose lifts not exceeding 10 inches. Compaction of a loose lift of fill shall be completed and approved before proceeding to the next loose lift placement. Each lift of fill shall be compacted to at least 95% of the maximum dry density determined by the Standard Proctor Compaction Test (ASTM D 698).

Verification testing of compacted soil density may be performed by nuclear gauge (ASTM D7759), sand cone (ASTM D1556) or rubber balloon (ASTM D2167). In the absence of specific project requirements, field density tests shall be performed at a minimum frequency of one test per 5,000 square feet of each lift of new fill.

Embankment fill shall be free of degradable rock such as shale that breaks down appreciably in the presence of water. Non-degradable rock may be used in embankments, but the maximum diameter of rock fragments shall be limited to two feet unless authorized by the City. The sizes of non-degradable rock fragments shall allow for uniform compaction throughout each lift by a vibratory tamping-foot roller. Lift thicknesses of non-degradable rock fragments shall be limited to a maximum of 3 feet. Fills comprised uniformly of non-degradable rock fragments do not require compaction testing and density evaluation similar to compacted soil fill, but the sufficiency of placement and compactive effort shall be evaluated for each lift.

### 5.3.3 Rock Excavation and Blasting

Rock excavation may consist of a percussion hammer (i.e., hoe ram) or blasting by presplitting. Vibrations associated with blasting may adversely affect adjacent structures and should be avoided. If blasting for presplitting is approved by the City, a precondition survey with vibration monitoring shall be used to limit potential for continued excessive vibrations and negative impacts to surrounding structures.

### 5.3.4 Slopes

Permanent slopes of compacted embankments or natural soil slopes that will be on the City property shall be no steeper than 3H:1V unless a waiver is granted by the City. A geotechnical investigation report with supporting engineering analyses must be submitted to the City with each waiver request. A geotechnical investigation and analysis shall be performed for all areas where fill or cut slope heights will be greater than 20 feet.

Slope stability analysis shall at least consist of evaluation of circular failure surfaces. Noncircular failure surfaces shall also be evaluated if thin, weak zones of soil are anticipated. The factor of safety against shallow and deep-seated failure of permanent slopes must be at least 1.3. If a structure may be adversely impacted by failure of a permanent slope, the factor of safety against slope failure must be at least 1.5.

Besides providing details of the subsurface exploration, a report of geotechnical investigation and slope analysis shall include the following items:

- Discussion of the project and proposed grading.
- Discussion of any evidence of springs and excessively wet areas.
- Slope recommendations for the steepest, stable slope that can be utilized for a given area.
- Slides, erosion, and/or faults observed at/near the project site should be discussed along with recommendations to prevent such issues on the subject project.
- If any of the soil or rock encountered in cuts are not suitable for reuse as structural fill on the project, the location and elevations of the unsuitable material shall be provided.

## 5.4 RETAINING WALLS

### 5.4.1 Overview

The intent of this Section is to provide technical guidelines and requirements for the design and construction of retaining walls on the City's property and within the City's right-of-way as well as retaining walls off City property or right-of-way that could

endanger the public if failure occurred. Technical guidance for wall designs has been taken primarily from the latest versions of the following: *AASHTO LRFD Bridge Design Specifications, Design and Construction of Mechanically Stabilized Earth Walls and Reinforced Soil Slopes (Publication No. FHWA-NHI-10-024)*, *Design Manual for Segmental Retaining Walls, Soil Nail Walls Reference Manual (Publication No. FHWA-NHI-14-007)*, *Simplified Procedures for the Design of Tall, Flexible Anchored Tieback Walls (Publication No. ERDC/ITL TR-02-9)*, and *Ground Anchors and Anchored Systems (Publication No. FHWA-IF-99-015)*.

### 5.4.2 Acceptable Wall Types

Acceptable fill walls include gravity or cantilevered retaining walls constructed of reinforced concrete, mechanically stabilized earth (MSE) walls utilizing geosynthetic reinforcement and a modular block face, and MSE walls utilizing metallic reinforcement and precast panel facing. Where the use of a fill wall may cause impacts to existing facilities or create concerns about constructability, temporary or permanent cut walls may be allowed upon review by the City.

Types of cut walls that may be acceptable include soil nail, sheetpiling, and soldier pile and lagging with or without tiebacks. Calculations and proposed sequence of construction methods shall demonstrate that cut walls are stable during construction and meet design requirements applicable to the selected wall system. The post-construction wall performance shall result in a maximum lateral wall deflection of 1.5% of the exposed wall height.

Utilities (i.e., pipes, cables, wires, etc.) may not be placed below or within the reinforced area of a retaining wall.

### 5.4.3 Geotechnical Investigation

Where wall height is defined as the elevation difference between the top of the wall face and the lower of the bottom of the footing (or lowest block) or 2 feet below finish grade at the wall face, retaining walls with any section greater than 6 feet high shall require geotechnical investigation to verify design parameters. Regardless of wall height, a geotechnical investigation shall be performed for walls on, above or below slopes steeper than 3H:1V and higher than 5 feet.

For geotechnical investigations, at a minimum, geotechnical borings shall be drilled on 100-foot centers along the length of the wall. The depth of each boring shall extend at least twice the wall height below the planned bearing elevation or to auger refusal, whichever is less. If unsuitable bearing materials are encountered, boring(s) shall be extended a minimum of 10 feet into competent soils (i.e., SPT N values  $\geq 6$  blows per foot) or to auger refusal.

#### 5.4.4 Drainage and Backfill Requirements

Adequate drainage of ground water away from a retaining wall is critical to the long term performance of the structure and shall be considered in all retaining wall designs. Perforated plastic pipe that is wrapped in geotextile to prevent soil loss shall be used to intercept ground water behind the wall near its bearing level for fill walls or finished grade for cut walls. Such interceptor pipe shall positively drain to daylight or to a closed stormwater system.

Except for MSE walls, weep holes with minimum diameter of 2 inches shall be formed within the wall face above and within 2 feet of finish grades. This will allow any ground water behind the wall face to readily exit and limit development of hydrostatic pressure. The maximum horizontal spacing for weep holes is 15 feet.

A ditch shall be used behind and horizontally within 5 feet of the wall face to direct stormwater runoff to the ends of the wall. Runoff shall be directed away from the ends of the wall as well as the front face of the wall.

The use of free-draining, granular material, such as AASHTO No. 57 stone, is required as backfill material for all walls. For MSE walls, the material used in the reinforced zone shall be free-draining, granular material that complies with manufacturer's recommendations as well as requirements given in the latest version of *Design and Construction of Mechanically Stabilized Earth Walls and Reinforced Soil Slopes*. The wall design may not utilize the shear strength of a granular backfill unless such material comprises the active wedge of soil extending back from the base of the wall.

#### 5.4.5 Stability Requirements

The internal and external stability of all retaining walls shall be analyzed by the Engineer of Record. All modes of failure as applicable for a given wall system, including those not noted within this document, shall be addressed during the preparation of the wall design. For critical structures, seismic stability shall also be considered. All permanent walls shall be designed for a minimum service life of 75 years.

The retaining wall design submittal shall include all hand calculations or all input parameters if computer software was used. All assumptions shall be clearly stated. Parameters requiring verification by the geotechnical investigation include soil strength parameters, soil material classification, and ground water levels.

##### 5.4.5.1 External and Internal Stability of Fill Walls

Fill walls may be designed using either Allowable Stress Design (ASD) or Load Resistance Factor Design (LRFD). When using LRFD methodology, the Engineer shall use the load and resistance factors given in the latest version of *AASHTO LRFD Bridge Design Specifications*. For ASD, the Engineer shall comply with

guidance provided in the latest edition of the *Design Manual for Segmental Retaining Walls*.

The external stability requirements are as follows:

- Factor of safety against overturning  $\geq 1.5$  (ASD)
- Eccentricity  $\leq B/6$  where B is width of footing or reinforced mass (ASD & LRFD)
- Factor of safety against sliding failure  $\geq 1.5$  (ASD)
- Factor of safety against bearing failure  $\geq 2.5$  (ASD)
- Capacity to Demand Ratio for sliding and bearing failures  $\geq 1.0$  (LRFD)

For MSE walls, internal stability shall include evaluation of each level of metallic or geosynthetic reinforcement for resistance against pull-out, breakage and connection strength.

### 5.4.5.2 Deformations

Design of walls shall account for both lateral and vertical deflections. In addition to considering nearby pavements and structures, post-construction settlements shall be tolerable to any utilities that may pass through or below a wall. Maximum post-construction total and differential settlements for flexible wall systems, such as MSE walls, shall be limited to 3 inches while less flexible walls shall be limited to 1 inch. If excessive total and/or differential settlements are probable for a given site, the Engineer of Record shall consider using vertical joints, greater wall embedment to decrease net stress changes, or ground improvement measures.

### 5.4.5.3 Global Stability

The critical failure surface that would originate behind a retaining wall and daylight below (or in front of) the wall shall produce a factor of safety against global failure of at least 1.5.

Regardless of slope inclination, global stability analysis shall be performed for any retaining wall proposed for construction on, above or below a slope. The analysis shall at least consist of evaluation of circular failure surfaces. Noncircular failure surfaces should also be evaluated if thin, weak zones of soil are anticipated at the site.

A seasonal high groundwater table shall be assumed for global stability analyses. If fine-grained bearing or retained soils are present, total and effective stress analyses shall be employed to ensure the critical failure mechanism has been



identified. Traffic or construction surcharge loads shall be taken as at least 250 pounds per square foot.

#### **5.4.6 Documentation and Notification Requirements**

Design calculations and drawings of all temporary and permanent retaining walls proposed within the City right-of-way, City easements, or on City property shall be submitted to the City for review, and construction shall not commence until the City approves the retaining wall plans. All design criteria identified in this document and current state of practice for a given wall system shall be evaluated. Drawings shall be stamped by an Engineer licensed in the State of Alabama. A report of geotechnical investigation shall also be submitted for review by the City.

### **5.5 DAM DESIGN GUIDELINES**

#### **5.5.1 Overview**

The intent of this Section is to provide technical guidelines and requirements for the design and construction of dams within the City that are not under the jurisdiction of other governmental entities. Technical guidance for dam design and dam safety has been taken primarily from the following: *Earth Dams and Reservoirs (TR-60)*, *Natural Resources Conservation Service (NRCS) Conservation Practice Standard – Pond, Code 378*, and *Federal Guidelines for Dam Safety: Emergency Action Planning for Dam Owners (FEMA 64)*.

#### **5.5.2 Definition of a Dam**

A dam shall be defined as any artificial barrier, including appurtenant works, which impounds or diverts water, wastewater or other fluids. Barring other bodies having primary jurisdiction, a dam shall be under the jurisdiction of the City if any of the following apply:

- Has an impounding capacity at a maximum water storage elevation of 20 acre-feet or more;
- Is at least 15 feet high, as measured from lowest open channel auxiliary spillway crest and the lowest point in the original cross section taken on the centerline of the dam;
- Will create a probable loss of human life in the event of failure or improper operation, regardless of height or storage capacity, as determined by the City; or
- Will create a probable loss of critical infrastructure in the event of failure or improper operation, regardless of height or storage capacity, as determined by the City.



If a dam meets any of those criteria, the Engineer of Record shall assign a hazard classification and provide the City with supporting engineering analyses. The City shall use the hazard category definitions in *TR-60*. Typically, a dam breach analysis must be performed to determine the hazard classification.

The City shall review plans and specifications for all jurisdictional dams. It is strongly advisable to discuss the design requirements for a prospective dam with the City prior to submittal of design plans and drawings.

### 5.5.3 Classes of Dams

The Natural Resources Conservation Service (NRCS) has established the following hazard classes for dams: Low, Significant and High.

Catastrophic failure of Low Hazard dams may result in damage to agricultural land, farm buildings or minor roads.

Catastrophic failure of Significant Hazard dams poses little threat to loss of life, but a failure may cause significant damage to main roads, minor railroads, or cause interruption of public utilities.

Catastrophic failure of those dams with High Hazard classification may cause loss of life; serious damage to residential, industrial, or commercial buildings; and/or damage to, or disruption of, important public utilities, such as water and sanitary pipes and structures, or transportation facilities, such as major highways or railroads. Dams proposed for construction in established or proposed residential, commercial, or industrial areas will be classified as High Hazard unless the Owner provides convincing evidence to the contrary.

### 5.5.4 Geotechnical Investigation

The geotechnical investigation of Low Hazard dams may be limited to geologic review if proposed dam's slopes are 5H:1V or flatter and the proposed dam's maximum height is less than 20 feet. Otherwise, at least one geotechnical boring shall be drilled in the proposed dam footprint to a depth of at least the maximum height of the proposed dam.

The Engineer of Record is responsible for determination of the minimum acceptable subsurface exploration program for Significant and High Hazard dams. At a minimum, a geotechnical exploration for Significant and High Hazard dams shall consist of at least two geotechnical borings that are spaced no more than 200 feet to depths of at least the maximum height of the proposed dam. Borings should not terminate prior to reaching competent soils (i.e., SPT N values of  $\geq 6$  blows per foot), weathered rock or bedrock.

To aid assessment of soil permeability within the impoundment area and dam footprint, evaluation of the native soils by geotechnical exploration is required for all impoundment areas in order that required measures can be taken, if needed, to minimize occurrence of unacceptably rapid fluid loss due to infiltration.

### 5.5.5 Design and Safety Requirements

*TR-60* describes design procedures and provides minimum requirements for planning and designing earth dams and associated spillways. It is required that the design of High and Significant Hazard dams follow the procedures that are set forth in *TR-60*. Because the size and type of structure used for the principal spillway is one of the most critical elements in the design of High and Significant Hazard dams, the Engineer of Record for the dam shall provide the City with detailed hydraulic, hydrologic, and structural computations supporting the selection of the apparatus. Detailed drawings and specifications relating to the apparatus shall be submitted to the City for review.

High and Significant Hazard dams must be capable of safely passing 100% of the probable maximum precipitation (PMP) through the principal and emergency spillways without overtopping the dam. In lieu of other published data, the PMP for the City shall be taken as approximately 44 inches for a period of 24 hours. This PMP value was interpolated from Figure 20 of the *Hydrometeorological Report No. 51, Probable Maximum Precipitation Estimates, United States East of the 105<sup>th</sup> Meridian*, Office of Hydrology, National Weather Service, United States Department of Commerce, NOAA, June 1978.

For a dam break analysis, the United States Army Corps of Engineers computer model, *HEC-RAS*, shall be used. This program simulates a breach, its resulting flood peak, and uses unsteady flow principles to route the flood downstream. The NRCS computer program, *SITES*, shall be used to model watershed runoff from a rainfall event and then route the resulting PMP hydrograph through the dam.

The top-of-dam elevation shall be used for the water surface elevation at the beginning of the dam break for a “wet-weather” case. The results of the downstream flood routing shall be used to establish the limits and plot the inundated areas for emergency conditions associated with the dam break discharge. An inundation map shall be created to depict the area that could be flooded should the hypothetical emergency occur. The inundation mapping shall be extended downstream to the point at which it falls within the Federal Emergency Management Agency (FEMA) regulatory floodplain.

Low Hazard dams shall be designed in accordance with *NRCS Conservation Practice Standard – Pond, Code 378*. This publication is applicable when the storage volume (measured in acre-feet) times the effective dam height is less than 3,000 acre-feet<sup>2</sup>. Effective dam height is defined as the difference in elevation between the lowest open channel auxiliary spillway crest and the lowest point in the original cross section taken

on the centerline of the dam. If a dam will provide greater storage or has an effective dam height greater than 35 feet, the dam design shall be in accordance with *TR-60*.

### 5.5.6 Documentation and Notification Requirements

The Owner shall provide written notification of completion of any jurisdictional dam to the City within 30 calendar days of its construction. The Owner shall also submit a letter by the Engineer of Record for the project that certifies that the dam was constructed in accordance with approved plans. If any deviations from the original design occurred, as-built drawings along with supporting documentation by Engineer of Record that details adequacy of as-built dam shall be submitted for approval. If constructed to attenuate stormwater runoff, dam certification shall be included with the certification of the stormwater storage facility.

As detailed below, the Owner is required to perform inspections and provide documentation of the inspections to the City. Frequency and type of reporting is based on the hazard class of the dam.

### 5.5.7 Types of Inspections

Several different types of dam inspections may be performed, including Informal Inspection, Regular Inspection, Formal Inspection, and Emergency Inspection. Dams and appurtenances shall be inspected regularly to identify conditions that may adversely affect the safety of a dam and its ability to perform as intended.

**Informal Inspection** – The visual inspection of the dam by the Owner or his/her representative to detect apparent signs of deterioration or other deficiencies of the dam structure or function shall be performed at least every 60 days and after every major rainfall event impacting the watershed. Informal inspections require that personnel conducting the inspection be knowledgeable about the dam and its appurtenances.

**Regular Inspection** – The City shall perform an annual courtesy inspection on all High and Significant Hazard dams. These inspections will typically coincide with the City's Annual Detention Pond Inspection. During the inspection, the City will perform visual assessment of obvious signs of structural weakness, instability or maintenance issues. If a critical item is discovered during the Regular Inspection, a Formal Inspection may be required immediately.

**Formal Inspection** – A formal inspection shall be performed at least once every four years. The Formal Inspection and performance evaluation of High and Significant Hazard dams shall be paid for by the Owner. If the dam has multiple Owners, the cost shall be split evenly among all Owners. The Owner shall hire a Professional Engineer, who is licensed in the State of Alabama, to review and determine the safety and integrity of the dam and appurtenant structures through a Formal Inspection.

Formal Inspections require a detailed site examination and include a thorough review of

records for design, construction, and past performance. Detailed underwater inspections shall be included as needed. The Owner shall submit the Formal Inspection of High and Significant Hazard dams for review and final approval by the City within 60 days of the completion of the inspection. An Emergency Action Plan (EAP) and Operation and Maintenance Manual shall be verified and current for all High Hazard dams. Formal Inspection reports for High Hazard dams shall be considered incomplete without these documents. As part of the Formal Inspection, a review of past performance shall be performed to assess any trends related to maintenance or other issues.

**Emergency Inspection** – An Emergency Inspection is an unscheduled evaluation of a dam and its appurtenances after occurrence of natural events, such as flooding or earthquake, or when conditions are observed that appear to immediately threaten the safety of the dam. An Emergency Inspection is applicable to any hazard classification and requires immediate attention. Findings from an Emergency Inspection may warrant immediate performance of a Formal Inspection.

### 5.5.8 Inspection Guidelines

The inspection guidelines are intended to assist the dam's Owner to better understand the requirements, responsibilities, and duties inherent with dam ownership and to provide a consistent approach to dam inspection and evaluation.

The Visual Inspection Checklist for dam inspection is located in Appendix 5A and shall be used during inspections. The Engineer of Record will recognize that portions of the guidelines will not apply to smaller dams and are expected to use professional judgment in preparing an inspection report. The City shall perform annual, regular inspections on all jurisdictional dams in conjunction with their annual detention pond inspections.

The Owner and/or his/her representative shall be responsible for the proper operation, maintenance and structural integrity of the dam. In order to fulfill this responsibility, the Owner and/or his/her representative shall perform a visual inspection of the dam at least every 60 days. Any observed condition changes that may be symptomatic of dam failure shall be immediately reported to the City, and an Emergency Inspection shall be performed by the Owner or his/her representative.

### 5.5.9 Emergency Action Plan

The Owner of a dam classified as High Hazard shall develop an Emergency Action Plan (EAP) that must be approved by the City. Basic considerations for preparing an EAP and a suggested EAP format can be found in the latest edition of the Federal Emergency Management Agency's *FEMA 64 – Federal Guidelines for Dam Safety: Emergency Action Planning for Dam Owners*.

An EAP shall be to the detail warranted by the size and location of the dam and

reservoir. It shall include evaluation of downstream inundation hazards resulting from floods or dam failure, and upstream conditions that might result from major land displacements or increased flood flows, including the effects from failure of upstream dams.

The EAP shall include inundation maps for the flows resulting from design floods and from possible failure of the dam. The EAP shall be submitted to the City. A review of the EAP shall be performed concurrent with Formal Inspections, and updates shall be made to the EAP as recommended by *FEMA 64*.

DRAFT

## References

*LRFD Bridge Design Specifications, 9<sup>th</sup> Edition*, American Association of State Highway and Transportation Officials (2020)

*Design and Construction of Mechanically Stabilized Earth Walls and Reinforced Soil Slopes (Publication No. FHWA-NHI-10-024)*, U.S. Department of Transportation, Federal Highway Administration (2009)

*Design Manual for Segmental Retaining Walls, 3<sup>rd</sup> Edition*, National Concrete Masonry Association (2010)

*Soil Nail Walls Reference Manual (Publication No. FHWA-NHI-14-007)*, U.S. Department of Transportation, Federal Highway Administration (2015)

*Simplified Procedures for the Design of Tall, Flexible Anchored Tieback Walls (Publication No. ERDC/ITL TR-02-9)*, U.S. Army Corps of Engineers (2002)

*Ground Anchors and Anchored Systems (Publication No. FHWA-IF-99-015)*, U.S. Department of Transportation, Federal Highway Administration (1999)

*Earth Dams and Reservoirs (TR-60)*, U.S. Department of Agriculture (2005)

*Conservation Practice Standard: Pond, Code 378*, Natural Resources Conservation Service (2011)

*Federal Guidelines for Dam Safety: Emergency Action Planning for Dams (FEMA 64)*, Federal Emergency Management Agency (2013)

*Hydrometeorological Report No. 51, Probable Maximum Precipitation Estimates, United States East of the 105<sup>th</sup> Meridian*, U.S. Department of Commerce and U.S. Department of the Army (1978)

**APPENDIX 5A**  
**VISUAL INSPECTION CHECKLIST**

DRAFT

DRAFT



# VISUAL INSPECTION CHECKLIST

PHENIX CITY  
PUBLIC WORKS DEPARTMENT

INSPECTION YEAR: \_\_\_\_\_

TYPE OF INSPECTION (CIRCLE ONE): **Informal** **Regular** **Formal**

DAM NAME: \_\_\_\_\_

DAM INVENTORY NO: \_\_\_\_\_

LOCATION: \_\_\_\_\_ ¼ of the \_\_\_\_\_ ¼, Section \_\_\_\_\_, Township \_\_\_\_\_, Range \_\_\_\_\_, \_\_\_\_\_ County (Lee or Russell)

OWNER: \_\_\_\_\_

OPERATOR: \_\_\_\_\_

DATE OF INSPECTION: \_\_\_\_\_

## RESERVOIR INFORMATION

Normal Reservoir Elevation (ft): \_\_\_\_\_

Reservoir Elevation at time of inspection (ft): \_\_\_\_\_

WEATHER CONDITIONS (including recent rainfall): \_\_\_\_\_

\_\_\_\_\_  
\_\_\_\_\_

## INSPECTION PERSONNEL

Alabama Licensed Professional Engineer(s):

<u>Name</u>	<u>Affiliation</u>	<u>Area of Expertise</u>
-------------	--------------------	--------------------------

\_\_\_\_\_

\_\_\_\_\_

\_\_\_\_\_

\_\_\_\_\_

Non-Licensed technical expert(s) and advisors(s):

<u>Name</u>	<u>Affiliation</u>	<u>Area of Expertise</u>
-------------	--------------------	--------------------------

\_\_\_\_\_

\_\_\_\_\_

\_\_\_\_\_

\_\_\_\_\_

DRAFT

City Representative(s):

Name    Affiliation

---

---

---

---

Dam Owner Representative(s):

Name    Affiliation

---

---

---

---

Others:

Name    Affiliation

---

---

---

---

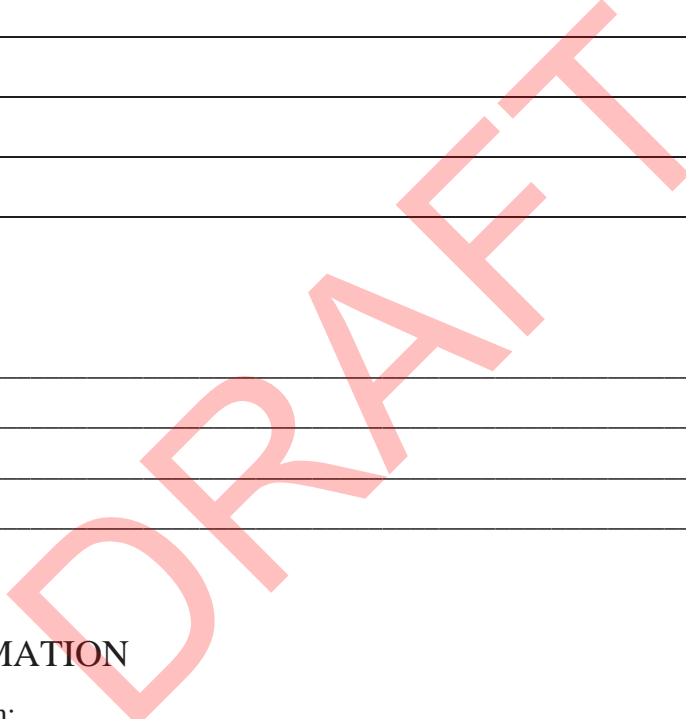

### GENERAL INFORMATION

Name of Dam: River Basin:

Stream Name: \_\_\_\_\_ Tributary of: \_\_\_\_\_

Latitude (N): \_\_\_\_\_ Longitude (W): \_\_\_\_\_

Purpose of Dam: \_\_\_\_\_

Hazard Classification: \_\_\_\_\_ Drainage Area (sq. mi.): \_\_\_\_\_

Height of Dam (ft): \_\_\_\_\_ Length (ft): \_\_\_\_\_

Normal Surface (ac): \_\_\_\_\_ Normal Capacity (ac-ft): \_\_\_\_\_

Maximum Surface (ac): \_\_\_\_\_ Maximum Capacity (ac-ft): \_\_\_\_\_

Principal Spillway Capacity (cfs): \_\_\_\_\_ Emergency Spillway Capacity (cfs): \_\_\_\_\_

DRAFT

Are the spillway(s) adequate for this classification of dam?

Principal: Yes No

Emergency: Yes No

If not, what percent of the PMP can be passed?

Principal: \_\_\_\_\_%

Emergency: \_\_\_\_\_%

## HISTORY

Date Constructed: \_\_\_\_\_

Date(s) Reconstructed: \_\_\_\_\_

Designer: \_\_\_\_\_

Constructed by: \_\_\_\_\_

Owner & Address: \_\_\_\_\_

Owner Telephone Number: \_\_\_\_\_

Owner/Operator present during inspection : Yes No

## PREVIOUS INSPECTIONS (date)

Last Informal Inspection: \_\_\_\_\_

Last Regular Inspection: \_\_\_\_\_

Last Formal Inspection: \_\_\_\_\_

## EMERGENCY ACTION PLAN (Required for all High and Specified Significant dams)

Date of Approved Plan: \_\_\_\_\_

Date of Plan Revision: \_\_\_\_\_

Is the notification flowchart complete and current? Yes No

Is inundation mapping included? Yes No

Are emergency materials and equipment identified? Yes No

When was the plan last tested? \_\_\_\_\_

DRAFT

**DOWNSTREAM HAZARD CLASSIFICATIONS**

Present Hazard Classification: \_\_\_\_\_

Changes in Downstream Land Use and Habitation since last inspection: \_\_\_\_\_

Is present Classification appropriate? \_\_\_\_\_

**OPERATION AND MAINTENANCE**

Date of Operation and Maintenance Plan: \_\_\_\_\_

Are instructions adequate? \_\_\_\_\_

Do operating personnel follow instructions? \_\_\_\_\_

What are operating personnel capabilities? \_\_\_\_\_

**EXAMINATION OF EMBANKMENT DAMS**

**DESCRIPTION OF STRUCTURE**

Embankment Material: \_\_\_\_\_

Cutoff Type (If Known): \_\_\_\_\_

Impervious Core (If Known): \_\_\_\_\_

Internal Drainage System: \_\_\_\_\_

Movement (Horizontal and Vertical Alignment): \_\_\_\_\_

Junctions with Abutments or Embankments: \_\_\_\_\_

Miscellaneous: \_\_\_\_\_

**CREST**

Width of Crest: \_\_\_\_\_

Erosion on Crest Present: \_\_\_\_\_

Surface Cracks: \_\_\_\_\_

Settlement: \_\_\_\_\_

Unusual Conditions:  
\_\_\_\_\_  
\_\_\_\_\_

DRAFT



UPSTREAM SLOPE

Slope (Estimate) (H:V): \_\_\_\_\_

Trees, Undesirable Growth or Debris, Animal Burrows): Sloughing, Subsidence or Depressions: \_\_\_\_\_

Slope Protection: \_\_\_\_\_

Unusual Conditions: \_\_\_\_\_

DOWNSTREAM SLOPE

Slope (Estimate) (H:V): \_\_\_\_\_

Trees, Undesirable Growth or Debris, Animal Burrows): \_\_\_\_\_

Sloughing, Subsidence or Depressions: \_\_\_\_\_

Surface Cracks or Movement at Toe: \_\_\_\_\_

Seepage: \_\_\_\_\_

External Drainage System (Ditches, Trenches, Blankets): \_\_\_\_\_

Condition Around Outlet Structure: \_\_\_\_\_

Unusual Conditions: \_\_\_\_\_

GROIN AND TOE AREA

Erosion around Groin Area: \_\_\_\_\_

Seepage at Groin Area: \_\_\_\_\_

Signs of Movement: \_\_\_\_\_

Depressions, Sinkholes: \_\_\_\_\_

Unusual Conditions: \_\_\_\_\_

SEEPAGE AND TOE DRAIN/RELIEF WELL FLOW SUMMATION

<u>Location</u>	<u>Estimated Flow</u>	<u>Color (Turbidity)</u>
_____	_____	_____
_____	_____	_____
_____	_____	_____
_____	_____	_____

DRAFT

---

---

**EXAMINATION OF SPILLWAYS AND OUTLET WORKS**

**TYPE(S) AND DESCRIPTION OF SPILLWAY(S)**

Principal: \_\_\_\_\_

Emergency: \_\_\_\_\_

Other: \_\_\_\_\_

**FOR EACH SPILLWAY THE FOLLOWING ASPECTS MUST BE EXAMINED WHERE APPROPRIATE**

**ENTRANCE CHANNEL**

Description: \_\_\_\_\_

Vegetation (Trees, Bushes): \_\_\_\_\_

Debris: \_\_\_\_\_

Channel Side-Slope Stability: \_\_\_\_\_

Slope Protection/Erosion: \_\_\_\_\_

Unusual Conditions: \_\_\_\_\_

**SPILLWAY CREST**

Description: \_\_\_\_\_

Condition of Material: \_\_\_\_\_

Signs of Movement: \_\_\_\_\_

Joints: \_\_\_\_\_

Unusual Conditions: \_\_\_\_\_

**INLET RISER**

Description: \_\_\_\_\_

Condition of Material: \_\_\_\_\_

Signs of Movement: \_\_\_\_\_

Joints: \_\_\_\_\_

Floor: \_\_\_\_\_

Unusual Conditions: \_\_\_\_\_

---

DRAFT

**SPELLWAY WING WALLS**

Description: \_\_\_\_\_  
Condition of Material: \_\_\_\_\_  
Signs of Movement: \_\_\_\_\_  
Joints: \_\_\_\_\_  
Drains: \_\_\_\_\_  
Unusual Conditions: \_\_\_\_\_  
\_\_\_\_\_

**DOWNSTREAM APRON**

Description: \_\_\_\_\_  
Condition of Material: \_\_\_\_\_  
Signs of Movement: \_\_\_\_\_  
Unusual Conditions: \_\_\_\_\_  
\_\_\_\_\_

**CONDUITS**

Description: \_\_\_\_\_  
Condition of Material: \_\_\_\_\_  
Signs of Movement: \_\_\_\_\_  
Joints: \_\_\_\_\_

Seepage:

<u>Location</u>	<u>Estimated Flow</u>	<u>Turbidity</u>
_____	_____	_____
_____	_____	_____
_____	_____	_____

Unusual Conditions: \_\_\_\_\_  
\_\_\_\_\_

**TRASH RACKS**

Description: \_\_\_\_\_  
Condition of Material: \_\_\_\_\_  
Unusual Conditions: \_\_\_\_\_  
\_\_\_\_\_

DRAFT

**CHUTES**

Description: \_\_\_\_\_  
Condition of Material: \_\_\_\_\_  
Signs of Movement: \_\_\_\_\_  
Joints: \_\_\_\_\_  
Unusual Conditions: \_\_\_\_\_  
\_\_\_\_\_

**STILLING BASIN**

Description: \_\_\_\_\_  
Condition of Material: \_\_\_\_\_  
Signs of Movement: \_\_\_\_\_  
Erosion: \_\_\_\_\_  
Unusual Conditions: \_\_\_\_\_  
\_\_\_\_\_

**OUTLET CHANNEL**

Vegetation (Trees, Bushes): \_\_\_\_\_  
Debris: \_\_\_\_\_  
Channel Side-Slope Stability: \_\_\_\_\_  
Erosion: \_\_\_\_\_  
Unusual Conditions: \_\_\_\_\_  
\_\_\_\_\_

**LOW LEVEL OUTLET**

Description: \_\_\_\_\_  
Condition: \_\_\_\_\_  
Trash Rack: \_\_\_\_\_  
Leakage: \_\_\_\_\_

<u>Location</u>	<u>Estimated Flow</u>
_____	_____
_____	_____
_____	_____

DRAFT



Unusual Conditions: \_\_\_\_\_  
\_\_\_\_\_

Was the low-level outlet operated during the inspection?    Yes    No

Were there difficulties operating the low-level outlet?    Yes    No

When was the low-level outlet last operated and did this conform with the Operation and Maintenance Procedures?

Miscellaneous: \_\_\_\_\_  
\_\_\_\_\_

### EMERGENCY SPILLWAY

Description: \_\_\_\_\_

Vegetation (Trees, Bushes): \_\_\_\_\_

Debris: \_\_\_\_\_

Channel Side-Slope Stability: \_\_\_\_\_

Slope Protection/Erosion: \_\_\_\_\_

Unusual Conditions: \_\_\_\_\_  
\_\_\_\_\_

### OTHER SPILLWAY

Description: \_\_\_\_\_

Vegetation (Trees, Bushes): \_\_\_\_\_

Debris: \_\_\_\_\_

Channel Side-Slope Stability: \_\_\_\_\_

Slope Protection/Erosion: \_\_\_\_\_

Unusual Conditions: \_\_\_\_\_  
\_\_\_\_\_

DRAFT

*EXAMINATION OF OTHER FEATURES*

INSTRUMENTATION (Monumentation/Surveys, Observation Wells, Weirs, Piezometers, Etc.) location, condition:

---

---

---

---

(A separate report including instrument readings, condition of instruments, observations, and conclusions based upon the collected data should be attached.)

RESERVOIR

Slopes: \_\_\_\_\_

Sedimentation: \_\_\_\_\_

Unusual Conditions Which Affect Dam: \_\_\_\_\_

Unusual Conditions: \_\_\_\_\_

---

APPURTENANT STRUCTURES (Power House, Gatehouse, Penstocks, Water Supply, Other)

Description and Condition of each:

---

---

---

---

---

---

---

---

---

---

DRAFT

*CONCLUSIONS*

I certify that the above dam was personally inspected by me and the conditions described herein are correct to the best of my knowledge and belief.

I recommend the following repairs be made immediately: \_\_\_\_\_

\_\_\_\_\_  
\_\_\_\_\_

The following long-term improvements should also be undertaken: \_\_\_\_\_

\_\_\_\_\_

The following studies should also be undertaken: \_\_\_\_\_

\_\_\_\_\_

Have the recommendations above included those from previous Regular or Formal Inspections? \_\_\_\_\_

\_\_\_\_\_

Does the Emergency Action Plan or the Operation and Maintenance Procedures require revision? \_\_\_\_\_

\_\_\_\_\_

Name of Professional Engineering Company/Consultant Representing the Owner: \_\_\_\_\_

Company/Consultant Address: \_\_\_\_\_

Company/Consultant Telephone Number: \_\_\_\_\_

Alabama Licensed Professional Engineer representing the dam owner in responsible charge of the inspection:

Sign: \_\_\_\_\_ Date: \_\_\_\_\_

Alabama Professional Engineer License Number: \_\_\_\_\_

SEAL

(Department use only)

.....

Dam Name: \_\_\_\_\_

Reference No.: \_\_\_\_\_

Hazard Classification: \_\_\_\_\_

DRAFT

## 6.0 DRAINAGE

### 6.1 INTRODUCTION

The purpose of this section of the Manual is to provide requirements for the design, installation, and maintenance of stormwater systems that are under the jurisdiction of the City of Phenix City. The primary audience for this chapter is the roadway hydraulics engineer with substantial experience in designing and/or maintaining stormwater systems.

City requirements do not preclude any additional requirements set forth by other State or Federal agencies. Design and construction of any drainage systems on roadways controlled by ALDOT shall be in accordance with applicable ALDOT drainage requirements and shall be properly permitted prior to construction.

All subdivisions and developments shall include adequate stormwater management facilities. The stormwater management plan shall provide a design adequate to control stormwater peak flows, runoff volume, and velocity in accordance with this Manual. In general, the stormwater management plan shall utilize design frequency criteria based on site specific conditions that relate to protection of life and property. Specific items to be included in the stormwater management plan can be found in Section 6.4.1 of this Manual.

Prior to or during the site design process, applicants are encouraged to contact and consult with the City Engineer to discuss stormwater management conceptual plans and receive feedback regarding any site specific stormwater management concerns or additional controls that may be required to protect critical areas, resources, or to further reduce velocities or discharges. The City Engineer may impose additional requirements deemed necessary to control the quality, quantity, volume, timing, and rate of storm water runoff. Certain areas within the City may necessitate additional stormwater management requirements.

The City's Illicit Discharge Detection and Elimination Program (IDDE Ordinance) defines permitted and unpermitted discharges into the City's MS4 system. An additional Industrial permit may be required for industrial classified discharges not permitted under the national construction stormwater discharge permit.

Well plans must meet the requirements of the Alabama Department of Environmental Management (ADEM) and other regulatory agencies. Combined storm and sanitary sewer plans are prohibited.

### 6.2 DESIGN ELEMENTS

#### 6.2.1 Stormwater Hydrology

**Rainfall Data** - The City prefers the use of rainfall data found within the NOAA Atlas 14 publication. Atlas 14 data can be found on NOAA's webpage at the following link:

<https://hdsc.nws.noaa.gov/hdsc/pfds/>. Other rainfall estimate methodologies may be acceptable provided written approval is obtained from the City Engineer prior to their use.

**Time of Concentration** – The City prefers time of concentrations be calculated using the USDA’s TR-55 methodology. The TR-55 Manual can be found on the USDA’s webpage at this link: [https://www.nrcs.usda.gov/Internet/FSE\\_DOCUMENTS/stelprdb1044171.pdf](https://www.nrcs.usda.gov/Internet/FSE_DOCUMENTS/stelprdb1044171.pdf).

**Hydrology Calculations** – The following methodologies may be used for hydrology calculations:

- **Rational Method** – The Rational Method may only be used to calculate runoff to drainage inlets and to calculate storm sewer peak flows in pipes used in the design of drainage systems. The Rational Method may only be used for contributing drainage areas less than 10 acres. Acceptable C values may be found in the latest edition of the ALDOT Hydraulics Manual, Section 4.1.3.3. Minimum time of concentration shall be 5 minutes. Maximum time of concentration for the Rational Method shall be 15 minutes. If drainage areas are larger than 10 acres or time of concentration exceeds 15 minutes, other design methodologies shall be used.

The Rational Method shall be used for hydraulic design of roadway drainage systems but not to develop hydrographs for design of stormwater storage facilities. Hydrographs determined by the Rational Method shall never be used for design or analysis. The Modified Rational Methodology shall not be used for storage design.

- **NRCS Curve Number Methodology** – The NRCS Curve Number Methodology may be used to calculate peak flow and stormwater volumes using the appropriate 24-hour storm. Additional information and curve numbers can be found in the United States Department of Agriculture NRCS Urban Hydrology for Small Watersheds (TR-55). Curve numbers are presented in Table 2-2a of this publication. The most recent version of TR-55 can be found at the following link: [https://www.nrcs.usda.gov/Internet/FSE\\_DOCUMENTS/stelprdb1044171.pdf](https://www.nrcs.usda.gov/Internet/FSE_DOCUMENTS/stelprdb1044171.pdf).

Soil types can be found in the NRCS web soil survey located at this link: <https://websoilsurvey.sc.egov.usda.gov/App/HomePage.htm>.

- **Regional Regression Equations** – Regional Regression Equations, as published by the USGS, may be used provided they meet the criteria outlined in the Regional Regression Equations report.



Post development runoff rates must adhere to the requirements in the most current edition of the City's Erosion and Sediment Control Policy.

### **6.2.2 Storm Drain Design**

Calculations for determining peak flows shall be determined using the methodologies established in Section 6.2.1 of this Manual. The following is the minimum design criteria:

- Culverts and cross drains: 25 years (Check for 100 years)
- Ditches and closed systems: 25 years
- Bridges: 50 to 100 years (Check for 100 year)

These requirements constitute a minimum requirement. It is the responsibility of the Engineer of Record to determine whether to design in accordance with the minimum requirements or to design to a higher standard. The City's details for residential and commercial turnouts to City streets provide the minimum standards for pipes under driveway turnouts (see Appendices 4F and 4G).

Where a public storm water system is available, the developer shall submit a request to the City to connect his/her storm water management facilities to the public storm water system. If no public storm water system exists, the developer shall recommend means to adequately dispose of storm water runoff from the site. Post construction flow rates may not exceed pre-construction flow rates.

All proposed conduits or channels shall be of sufficient capacity to accommodate potential runoff from the developed area, including the entire upstream drainage area. The engineer shall include a statement in his submittals to the City Engineer that the design for all proposed conduits or channels have included all upstream drainage areas. If an existing channel runs through a proposed development, the engineer must consider this flow when designing detention and outfall structures. Section 10 ½ -6 of the City's Ordinance No. 2017-01 for Stormwater Management discusses permitted and unpermitted discharges into the storm system.

Manhole or inlet access for storm sewer systems shall be provided at a maximum spacing of 300 feet for pipes 24 inches or less in diameter and 400 feet for pipes exceeding 24 inches. Manholes shall also be provided at each change in line and grade.

Storm water conveyance systems, whether conduit or open channel, shall be located within the right-of-way where practical. The minimum width of a new drainage easement shall be twenty (20) feet or three (3) times the outside diameter of the pipe being installed. The minimum easement width for open channels shall be twenty (20) feet or the width of the channel at the top of bank plus 10 feet.

### **6.2.3 Surface Drainage**

Roadway drainage inlets shall be designed so that surface drainage is not carried across intersections and so that maximum gutter spread is not exceeded. Maximum gutter spread shall not exceed one half of the travel lane adjacent to the curb.

Driveways shall be constructed so that surface drainage from the roadway does not crossover onto residential or commercial roadside properties until it reaches the curb height or a minimum of 6 inches above the edge of pavement.

Per the City's Erosion and Sediment Control Policy, lots shall be graded 5% away from buildings for a minimum of ten (10) feet. Impervious surfaces shall have a minimum 0.5% slope, and pervious surfaces shall have a minimum of 2.0% slope. Finished floor elevations for buildings and garages shall be two (2) feet above the 100-year Base Flood Elevation (BFE) for all floodplains, including surface waters, streams, creeks, detention ponds, storm inlets, drainage channels, culvert inlets, etc.

The developer is required to carry away, by pipe or open channel, any spring or surface water existing prior to or as a result of the development.

Where a development is traversed by a watercourse, channel, or stream, a storm water easement shall be provided that conforms substantially to the lines of such water course. The width and construction shall be adequate for the intended purpose, including maintenance operations, and shall be approved by the City Engineer.

Drainage on State routes shall be designed in accordance with the ALDOT Hydraulic Manual.

### **Open Channels**

Minimum slope shall be 0.5% for paved channels and 2.0% for unpaved channels. Channel protection is required where channel velocities exceed safe velocities for vegetated lining due to increased grade or a change in channel cross-section, or where durability of vegetative lining is adversely affected by seasonal changes. Channel linings of rock, concrete, or other durable material may be required to protect and stabilize the channel.

In general, a vegetated lining may be used to stabilize channels with a velocity of 0-5 ft/s. Rock riprap may be used when channel velocities are 5-10 ft/s. When rock riprap is required, a filter blanket shall be installed between the riprap and the base material. A filter blanket may consist of appropriately graded sand and/or gravel or a geotextile material. If channel velocities exceed 10 ft/s, a concrete lining shall be required to stabilize the channel. In addition, special methods or grade stabilization structures shall be utilized to reduce the velocity of the runoff and reduce erosion at the outlet from the concrete channel.

Alternatively, Turf Reinforcement Matting (TRM) may be used with a vegetative lining for channel velocities between 5-10 ft/s. TRMs are selected by ensuring the vegetative lining and TRM shear stress resistance is greater than the equivalent shear stresses anticipated in the channel.

#### **6.2.4 Detention and Retention Facilities**

At a minimum, all storm water management plans shall be designed such that the post construction peak flow rates match the pre-construction storm water runoff for the 2, 5, 10, 25, 50, and 100-year 24-hour design storms at the following locations:

- Location(s) of outfalls where stormwater leaves the site of the development,
- Locations of the next three downstream stormwater structures including at least one City owned structure, and
- Any locations between the development and the next three downstream City owned stormwater structures where existing flooding problems exist.

To protect stream channels from degradation and erosion, specific channel protection detention volume shall be provided. Storm water runoff to critical areas with sensitive resources or existing flooding issues may be subject to additional performance criteria or may need to utilize or restrict certain storm water management practices. Prior to, or during the site design process, applicants shall consult with the City Engineer to determine if they are subject to additional storm water management requirements.

Calculations for determining peak flows as found in this Manual shall be used for sizing all storm water facilities. If hydrologic or topographic conditions warrant greater control than required by this Manual, the City Engineer may impose additional requirements deemed necessary to control the quality, quantity, volume, timing, and rate of storm water runoff.

Adequate provisions shall be made within each development for required storm water management facilities. Storm water management facilities shall be constructed in conformity with State specifications and all other State and Federal laws and regulations.

Two (2) feet of freeboard shall be provided between the outlet structure post-developed storage elevation for the 100-year storm event and the top of dam. The emergency spillway shall be designed to handle the peak runoff from the improved contributing area assuming the control structure is not functional for the 100-year peak flow.

Detaining discharge from a site can sometimes exacerbate flooding downstream due to peak flow timing and/or increased volume of storm water runoff from a site. The applicant must demonstrate through hydrologic analyses that the detention facility will

not exacerbate flooding downstream. Detention requirements may be waived by the City Engineer in certain instances where it is demonstrated through an engineering study that meeting the detention requirement will exacerbate flooding downstream.

Underground detention is permitted with adequate verification of structural integrity and suitable soils and infiltration. Retention ponds are not permitted.

Detention systems must be constructed during the first phase of erosion control plans to eliminate damage to adjacent properties during construction. Detention systems shall be designed to function as sediment traps. Detention facilities used for sediment traps during construction shall be built in accordance with the City's Erosion and Sediment Control Policy, Section VII. Stormwater runoff from any development shall not exceed pre-developed peak flows for the 2, 5, 10 and 25-year events. The City Engineer may approve alternate measures to be used during construction provided the design meets the requirements in the City's Erosion and Sediment Control Policy. This policy only requires control of peak discharges up to the 25-year storm event due to the temporary use during construction. Permanent detention facilities shall control all peak discharges including the post-developed 100-year storm event and shall be constructed with an emergency overflow. Detention facilities used for sediment storage shall be cleaned out and meet permanent storage volume requirements before completion. If deposition of sediment has occurred, permanent detention systems must be restored to their design dimensions after construction is complete and shall be certified as part of the as-built submittal. This certification shall be submitted even if an as-built submittal is not required for the development.

Any detention facilities that rely on infiltration to reduce overall runoff volume will need to have supporting documentation addressing the soils.

No detention facilities, detention embankments, or ponding related to detention facilities will be permitted within public rights-of-way. Detention facilities shall be located within the parcel limits of the project under construction. If the project is part of a larger development, additional easements may be required as well as an agreement with all owners for maintenance of the detention facilities.

At a minimum, all detention ponds shall have a six (6) foot fence located two (2) feet above the 100-year storage elevation to prevent unauthorized access to the detention area. At least one gate is required, and all gates shall be locked. A temporary fence is required during construction. At the City's discretion, exemptions may be considered for small ponds where the depth is less than two (2) feet.

Detention ponds shall be tied to a parcel of land instead of a property owner. If a property owner abandons a property containing a pond, the City may temporarily maintain the pond and place a lien on the property to recover the cost of maintenance. These costs will be paid by the next owner.

### **6.2.5 BMPs for Control of Pollutants**

Section 10 ½ - 10 of the City's Ordinance No. 2017-01 for Stormwater Management discusses the requirement for installation of BMPs for control of pollutants.

### **6.2.6 Erosion and Sediment Control**

The City's Erosion and Sediment Control Policy controls the requirements for erosion control design. Any project disturbing greater than or equal to one (1) acre requires an NPDES permit. Section IV-D of the City's Erosion and Sediment Control Policy defines exclusions from the City's erosion control plan submission requirements. Section IV-D does not relieve the developer from other requirements in the City's policy and it does not relieve other regulations including State and Federal regulations. Section VII of the City's Erosion and Sediment Control Policy defines criteria for erosion control plans.

## **6.3 MATERIAL REQUIREMENTS**

Installation and material requirements of drainage systems shall be in accordance with the most recent ALDOT Standard Specifications for Highway Construction, Section 500. Concrete box culverts shall be designed and constructed according to requirements of the current ALDOT Standard Specifications for Highway Construction and the ALDOT Special and Standard Highway Drawings.

All pipe installed under a roadway must be Reinforced Concrete Pipe (RCP). High-Density Polyethylene (HDPE) pipe is allowed within the ROW as long as it is installed per the Phenix City specifications and manufacturer's installation requirements. No other pipe materials are allowed. All pipe sizes shall be a minimum of 18 inches. This requirement includes pipes under residential and commercial driveway turnouts. HDPE pipe shall be installed in accordance with the City's "High-Density Polyethylene (HDPE) Corrugated and Smooth Lined Thermoplastic Pipe Specification (For Gravity Flow Drainage Pipe Applications)".

## **6.4 SUBMITTAL REQUIREMENTS**

A storm water management plan shall be prepared for the project and shall include sufficient information to allow the City Engineer to evaluate potential impacts of all proposed development on the site, both present and future, on storm water runoff as well as effectiveness and acceptability of measures proposed for managing storm water runoff generated at the project site.

### **6.4.1 Plan Requirements**

The basic storm water management plan shall include the following:

- Written narrative describing the proposed overall site work;

- Proposed drainage patterns and locations of utilities, roads, and easements with limits of clearing and grading;
- Proposed structural storm water management facilities with maintenance plans;
- Written description of the site plan and justification of proposed changes in natural conditions (if requested by the City Engineer); and
- Soils Information. If a storm water facility depends on the hydrologic properties of soils (e.g., infiltration basins, underground detention, permanent pool), then a soils report shall be submitted. The soils report shall be based on onsite boring logs or soil pit profiles and soil survey reports. The number and location of required soil borings or soil pits shall be determined based on what is needed to determine the suitability and distribution of soil types present at the location of the control measure. The soils submittal shall also discuss the impacts the facility may have on the local karst topography. Facilities may be designed to infiltrate runoff to groundwater for up to a five-year storm event given adequate soils are present and the potential for groundwater pollution prevented as documented by a geotechnical professional engineer's signed report.

Per the City's SWMP, any new or modified outfalls are required to be mapped. Section 5 of the City's IDDE Ordinance provides the requirements for any new or modified outfalls as a result of the development. Activity 17 in Section 4.2.3 of the City's SWMP identifies additional requirements for NPDES industrial permitting.

Erosion and sediment control plan (ESCP) requirements are defined in Section VI of the City's Erosion and Sediment Control Policy. Modifications to the ESCP shall be communicated to the City Engineer within 24 hours or the next business day. The City has the discretion to request a full resubmittal of the erosion control plan. Section X of the City's Erosion and Sediment Control Policy defines variances and appeals.

### **6.4.2 Application Requirements**

Per section V-A of the City's Erosion and Sediment Control Policy, the applicant is required to file copies of the ADEM NPDES permit and obtain approval from the City. Land disturbing activity will not be permitted without written approval from the City.

The property owner is required to sign the City's "Notification of the Erosion and Sediment Control Policy of the City of Phenix City AL". This notification is typically signed with building/driveway permits.

### **6.4.3 Bonds & Fees**

The City may require a bond up to \$3,000 per acre of land disturbing activity. Section IV-C of the City's Erosion and Sediment Control Policy contains additional information. Section XIII defines application fees to be submitted with the ESC plans.

## 6.5 MAINTENANCE AND ONGOING INSPECTION REQUIREMENTS

Stormwater management facilities shall be owned, operated, and maintained by the development entities and shall not be accepted for inspection and maintenance by the City. The burden shall be on the developer and his/her engineer to provide evidence to the City Engineer in support of any proposal to alter or modify the requirement for detention. Stormwater runoff from development must not adversely affect downstream properties.

The City will require that a Stormwater Storage Facility Operation and Maintenance Agreement (O&M Agreement) be submitted for all proposed storage facilities. The O&M Agreement must include a description of the storage facility and its components and provide a maintenance schedule to ensure that the storage facility is operating as designed. If a storage facility is designed to provide sediment storage during construction, the O&M Agreement must also provide a maintenance schedule during construction operations. The O&M Agreement is required to be submitted prior to any certificates of occupancy being issued on sites that have newly constructed storage facilities. A separate O&M agreement is required for subdivision stormwater storage facilities. The O&M Agreements can be found in Appendix 6B (Lee County) and Appendix 6C (Russell County).

The City will require that an O&M Agreement be executed by the entity responsible for the upkeep and maintenance of newly constructed storage facilities. The O&M Agreement must be submitted to the City with the Stormwater Storage Facility Final Certification Form (see Appendix 6D). The O&M Agreement will contain the previously approved Operation and Maintenance Plan and identify the entity responsible for perpetual care, operation, maintenance, and associated liabilities of the storage facility along with a letter from the entity accepting the responsibilities as outlined in the O&M Agreement. The City will require that the O&M Agreement be recorded.

In addition to the owner performed inspections identified in the O&M Agreement, the City conducts annual inspections of all storage facilities within the City. The City will provide a copy of the inspection report to the entity responsible for the maintenance. This maintenance and/or remedial work identified during the City's inspection may be in addition to the required maintenance identified in the O&M Agreement. The owner of the pond shall submit evidence that the required maintenance and/or remedial repairs identified during the City inspections have been completed. Failure to follow the O&M Agreement and/or complete the necessary repairs identified during the City inspection will result in enforcement actions.

Section VIII-F of the City's Erosion and Sediment Control Policy defines ongoing inspection requirements by the City. Section IX-C gives the City the authority to detect and eliminate illicit connections and eliminate improper disposal and/or discharge from any property or site. The City's Ordinance No. 2017-01 for Stormwater Management, Section 10 ½-9, requires property owners to provide access to City inspectors in order to monitor discharges into the City's MS4 and grants the City authority to require the discharger to install monitoring equipment.



Section 10 ½ -11 of the City's Ordinance No. 2017-01 for Stormwater Management requires the property owner to maintain watercourses and stormwater structures passing through the property. Section 10 ½ -12 requires that the property owner notify the City of spills that may result in an illicit discharge.

## **References**

*Phenix City's Storm Water Management Program* (January 1, 2017)

*Phenix City's Ordinance No. 2017-1: Chapter 10 ½ - Stormwater Management* (February 2017)

*Phenix City's Illicit Discharge Detection and Elimination Program* (January 2017)

*Phenix City's Erosion and Sediment Control Policy* (Amended and Adopted February 21, 2007)

*Phenix City's High-Density Polyethylene (HDPE) Corrugated and Smooth Lined Thermoplastic Pipe Specification (For Gravity Flow Drainage Pipe Applications)*

*Low Impact Development Handbook for the State of Alabama*, Alabama Department of Environmental Management, Alabama Cooperative Extension System, & Auburn University

*Urban Hydrology for Small Watersheds (TR-55)*, United States Department of Agriculture (June 1986)

*ALDOT Hydraulic Manual* (2018)

*ALDOT Standard Specifications for Highway Construction* (2018)

*ALDOT Special and Standard Highway Drawings* (2021)

*SIR 2010-5012, Magnitude and Frequency of Floods for Urban Streams in Alabama* (2007)

*SIR 2007-5204, Magnitude and Frequency of Floods in Alabama* (2003)

*SIR 2004-5135, Magnitude and Frequency of Floods on Small Rural Streams in Alabama*

*WRIR 93-4186, Low-flow and Flow-duration Characteristics of Alabama Streams*

*NOAA Atlas 14 Precipitation Frequency Data Server*

<https://toolkit.climate.gov/dashboard-noaa-atlas-14-precipitation-frequency-data-server>



**APPENDIX 6A**  
**DRAINAGE DETAILS**

DRAFT

DRAFT

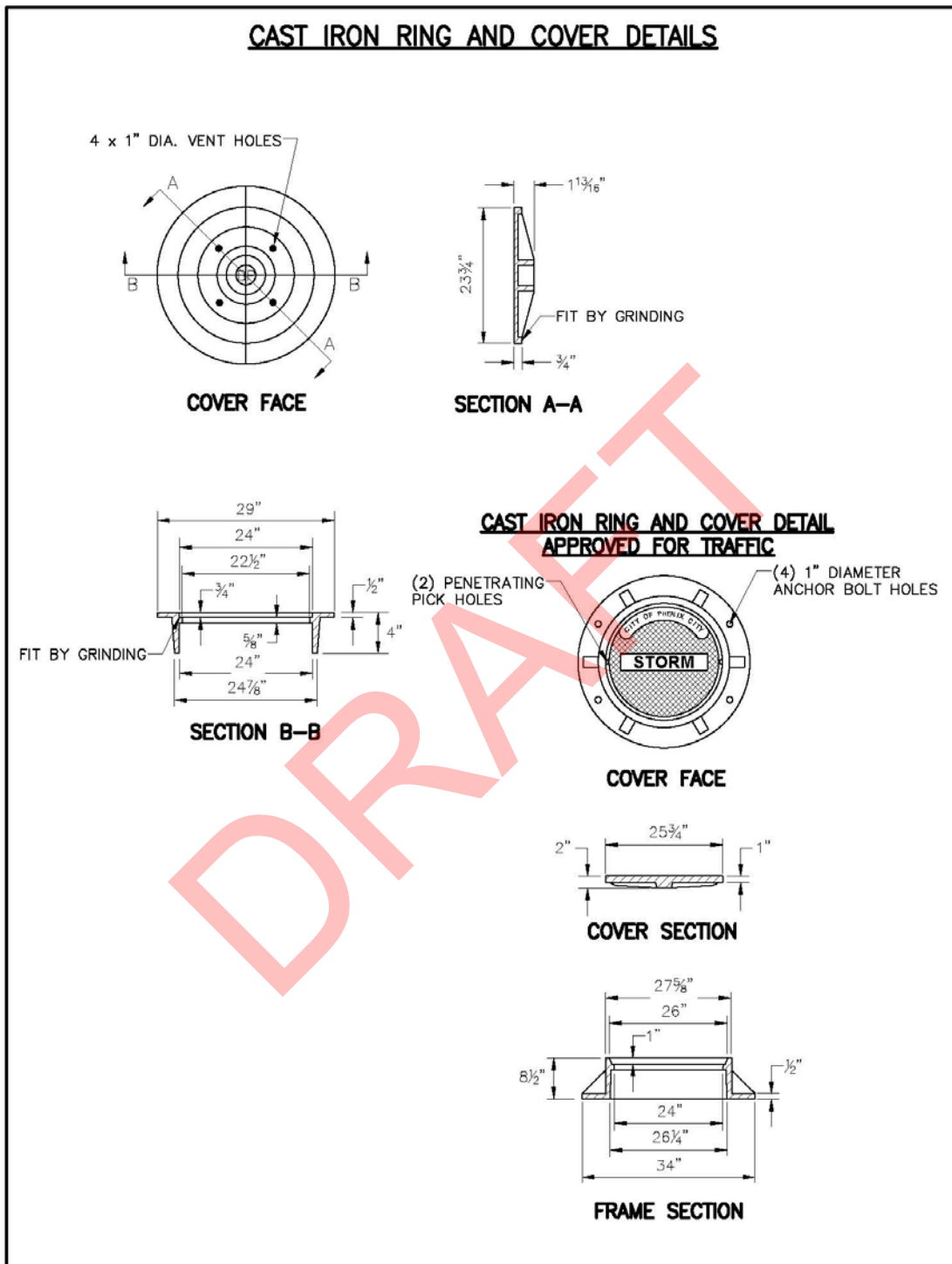

DRAFT

**DOUBLE WING INLET**

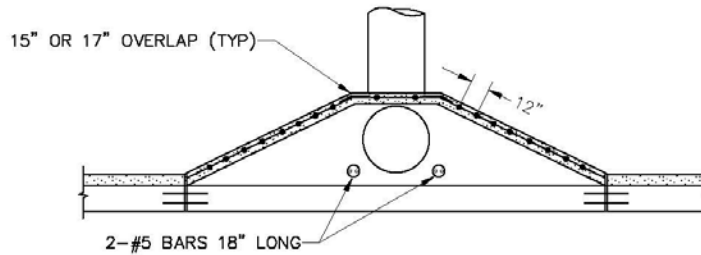

**DOUBLE WING INLET SLAB SECTION**

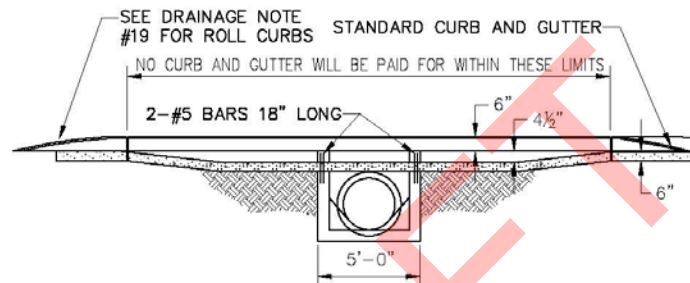

**DOUBLE WING INLET ELEVATION**

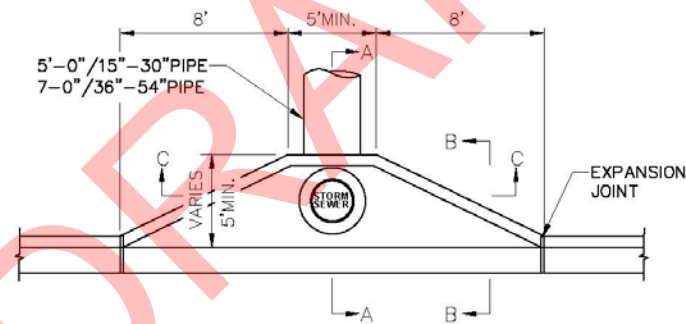

**DOUBLE WING INLET PLAN**

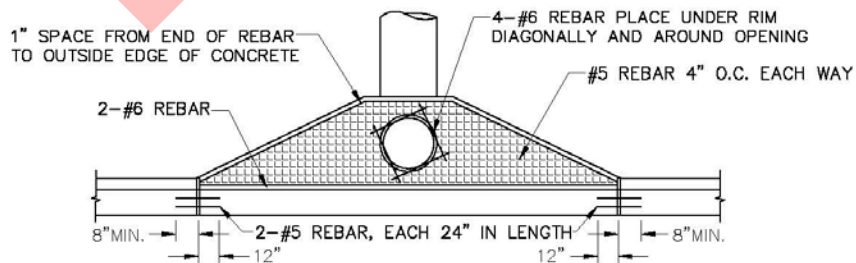

**DOUBLE WING INLET TOP SECTION**

DRAFT

**DOUBLE WING INLET**

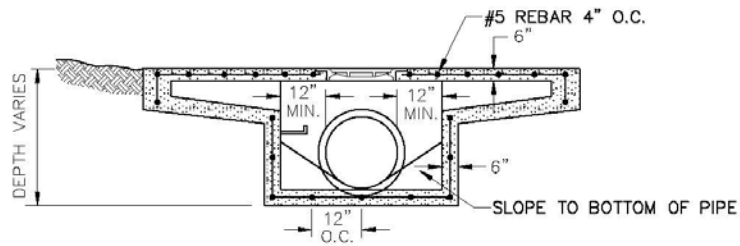

**DOUBLE WING INLET DETAIL CC**

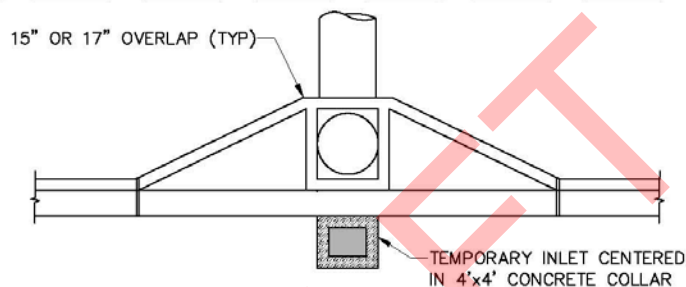

**PLAN VIEW**

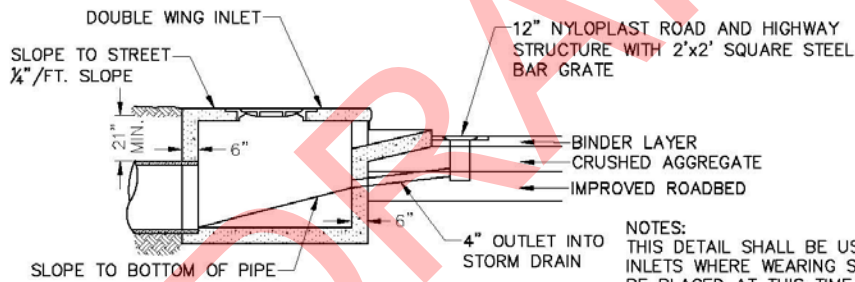

**PROFILE VIEW**

NOTES:  
THIS DETAIL SHALL BE USED AT THE SAG  
INLETS WHERE WEARING SURFACE WILL NOT  
BE PLACED AT THIS TIME.

INLET SHALL BE PLACED AT LOWEST POINT  
IN THE ROADWAY.

**SINGLE WING INLET**

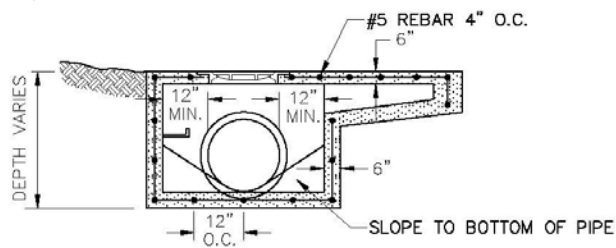

**SINGLE WING INLET DETAIL DD**

DRAFT



**SINGLE WING INLET**

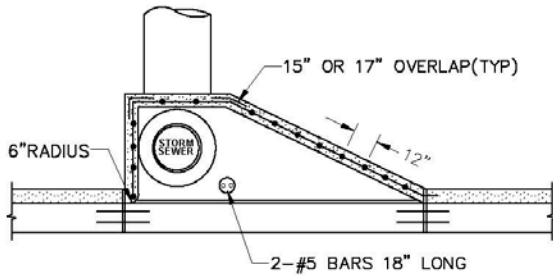

**SINGLE WING INLET SLAB SECTION**

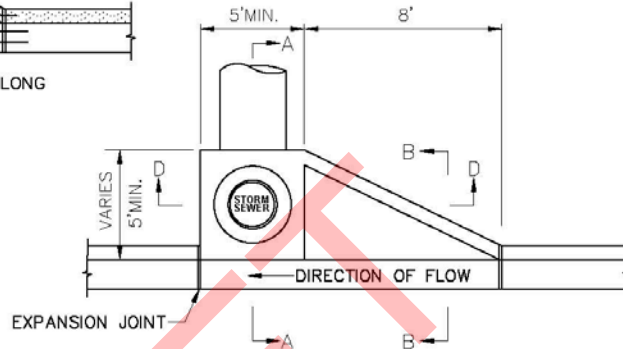

**SINGLE WING INLET PLAN**

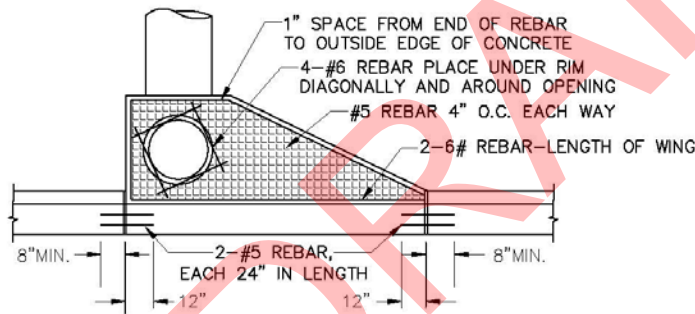

**SINGLE WING TOP SECTION**

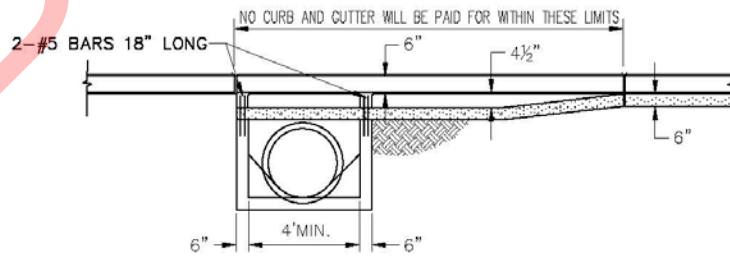

**SINGLE WING INLET ELEVATION**

DRAFT

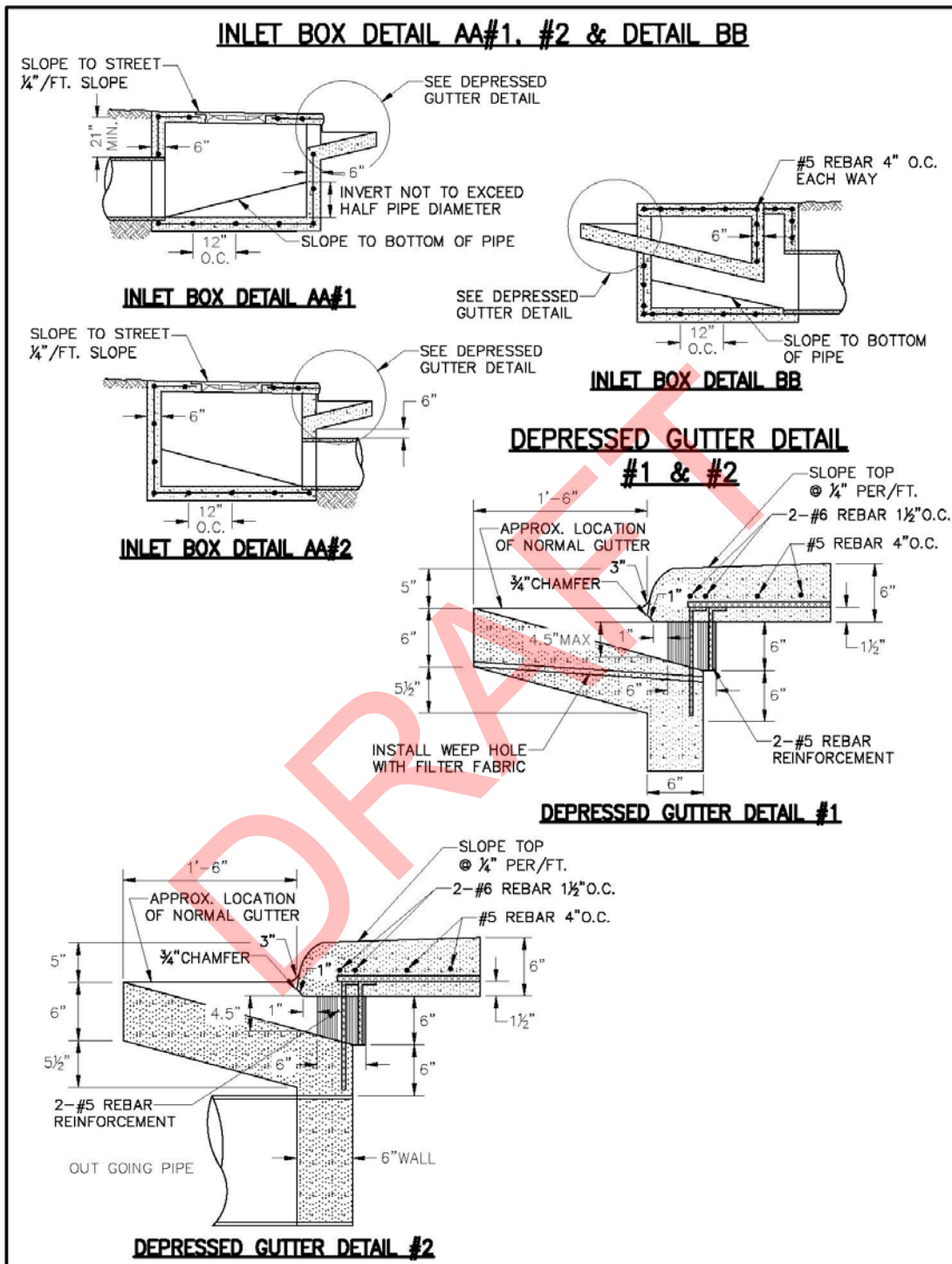

DRAFT

### DRAINAGE NOTES

1. HEADWALL AND WINGWALLS SHALL HAVE A RUBBED SMOOTH FINISH. PIPE SHALL BE CUT FLUSH WITH THE INSIDE FACE OF THE HEADWALL.
2. JUNCTION BOX INVERTS SHALL BE SMOOTH AND APPROXIMATE THE CROSS SECTION OF THE PIPE USED. AT LEAST 0.25' OF FALL IS REQUIRED ACROSS ALL JUNCTION BOXES AND/OR INLETS. THE FLOOR SHALL BE SLOPED TO DRAIN ALL WATER TO THE INVERT. ALL PIPE SHALL BE CUT FLUSH WITH THE FACE OF THE JUNCTION BOX AND INLET JUNCTION BOX.
3. CAST IRON FRAME AND COVER SHALL WEIGH 375 POUNDS IN TRAFFIC AND 325 POUNDS OFF TRAFFIC.
4. ALL PIPES SHALL BE LAID WITH ENDS ABUTTING AND TRUE TO LINE AND GRADE. PIPE SHALL BE FITTED AND MATCHED TO FORM A LINE WITH A SMOOTH, UNIFORM INVERT. GROUT SHALL THEN BE APPLIED SMOOTHLY TO THE OUTSIDE TOP TWO THIRDS AND THE INSIDE BOTTOM ONE HALF TO WATER PROOF ALL PIPE.
5. PRECAST MANHOLES MAY BE USED FOR PIPE UP TO 36". LARGER SIZES MUST BE APPROVED PRIOR TO USE.
6. FOR PIPE SIZES LARGER THAN 42", HEADWALLS SHALL BE AS SPECIFIED BY THE CITY ENGINEER.
7. INLETS SHALL NOT BE PLACED IN A RADIUS OF INTERSECTING STREETS OR DRIVES.
8. PRECAST ITEMS MUST BE APPROVED PRIOR TO USE.
9. CHAMFER STRIPS ARE REQUIRED ON ALL HEADWALL EDGES.
10. RIPRAP WITH GEOFABRIC IS REQUIRED AT ALL PIPE OUTLETS. THE SIZE OF THE PAD SHALL BE AS DESIGNED BY THE ENGINEER BUT SHALL BE CONSTRUCTED PER THE DETAIL.
11. DISTANCE FROM RADIUS POINT TO EXISTING EXPANSION OR CONSTRUCTION JOINT SHALL BE AT LEAST 3.0': IF LESS THAN 3.0', CURB AND GUTTER SHALL BE REPLACED TO EXISTING JOINT.
12. MINIMUM INSIDE DIMENSION OF JUNCTION BOXES AND INLETS SHALL BE 4 FEET.
13. TOP OF INLET SHALL BE THE SAME ELEVATION AS ADJOINING CURB AND GUTTER.
14. 2" MINIMUM WEEP HOLES SHALL BE CONSTRUCTED IN INLETS TO FACILITATE SUBGRADE DRAINAGE.
15. IF INLET ALSO SERVES AS A JUNCTION BOX, CONTOUR BOTTOM AS PER JUNCTION BOX REQUIREMENTS.
16. MORTAR: A CONCRETE MIX EQUIVALENT TO AT LEAST A 3000 PSI STABILITY.
17. NUMBER 5 REBAR SHALL BE INSTALLED INTO ALL CURB AND GUTTER COLD JOINT TIE INS, AT ALL INLETS & JUNCTION BOXES, OR TO BE DETERMINED BY THE PROJECT ENGINEER/PROJECT INSPECTOR.
18. INSTALL STEPS IN JUNCTION BOXES OR INLET EVERY 16" ON CENTER ACCESSIBLE TO MANHOLE COVER. AT LEAST ONE STEP IS REQUIRED PER BOX, MINIMUM.
19. FOUR FOOT (4') MINIMUM TRANSITIONS FROM ROLL CURB TO STANDARD CURB AND GUTTER TO ALLOW STANDARD INLET TO BE CONSTRUCTION.
20. INVERTS SHALL BE POURED CONCRETE. NO BRICK OR ROCKS SHALL BE USED AS FILLER MATERIAL.
21. #5 BARS REQUIRED IN GUTTER.
22. INVERTS SHALL NOT EXCEED HALF THE DIAMETER OF THE PIPE. NO FLAT AREAS ARE PERMITTED.
23. INLET TOPS SHALL BE SLOPED AT 1/4"/ft TOWARD THE STREET (SEE DETAIL).
24. CONCRETE USED FOR STORM STRUCTURES MUST HAVE A MINIMUM COMPRESSIVE STRENGTH OF 3000 psi.
25. MODIFIED INLETS MUST HAVE SAME CARRYING CAPACITY AS STANDARD INLETS. DIMENSIONS SHALL BE APPROVED BY CITY OF PHENIX ENGINEER PRIOR TO INSTALLATION.
26. HDPE CAN BE USED FROM RIGHT OF WAY OUT WITH CITY OF PHENIX APPROVAL.
27. AN EXPANSION JOINT MUST BE PROVIDED AT THE INLET / CURB FACE.
28. MECHANICAL TAMPING IS REQUIRED AROUND AND BEHIND INLETS.

DRAFT

### UTILITY CONFLICT JUNCTION BOX

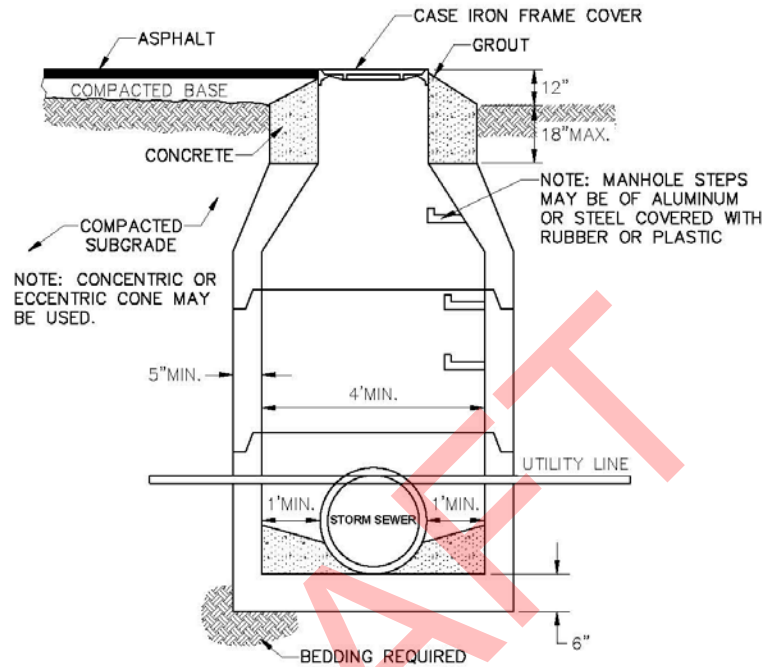

### SECTIONAL ELEVATION

NOTE:

1. INSTALL JUNCTION BOX WHEN THERE IS A CONFLICT BETWEEN STORM SEWER AND OTHER UTILITY LINES.
2. IF THE CONFLICTING UTILITY LINE IS A SANITARY SEWER LINE, REPLACE THE V.C. OR PVC PIPE WITH DUCTILE IRON PIPE.
3. IF POSSIBLE INSTALL THE CONFLICTING UTILITY IN THE UPPER  $\frac{1}{2}$  OF THE STORM SEWER.

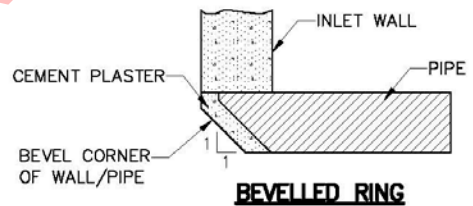

(POURED IN PLACE APPLICATION)

DRAFT



**HEADWALL DETAIL**

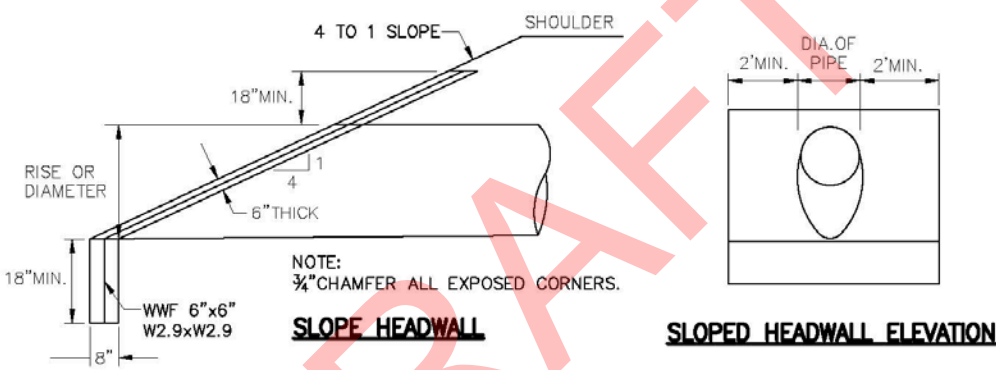
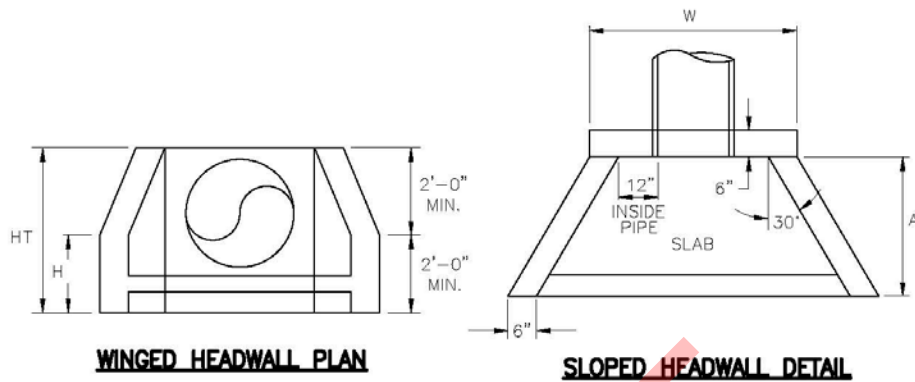

**PIPE SIZE CHART**

PIPE SIZE	A MIN.	W MIN.	H MIN.	HT MIN.
15 IN	4 FT	DIA + 3FT	2 FT	4 FT
18 IN	4 FT	DIA + 3FT	2 FT	4 FT
24 IN	4 FT	DIA + 3FT	2'-6"	4 FT
30 IN	4.5 FT	DIA + 3FT	2'-6"	4'-6"
36 IN	5 FT	DIA + 3FT	3 FT	5 FT
42 IN	5 FT	DIA + 3FT	3 FT	6 FT
48 IN	5.5 FT		3 FT	6'-6"
54 IN	6 FT		3'-6"	7 FT
60 IN	6.5 FT		3'-6"	7'-6"
72 IN	7 FT		4 FT	8 FT

NOTE: HEADWALL HEIGHT MAY VARY FROM THE CHART WITH APPROVAL OR RECOMMENDATION OF THE CITY ENGINEER.

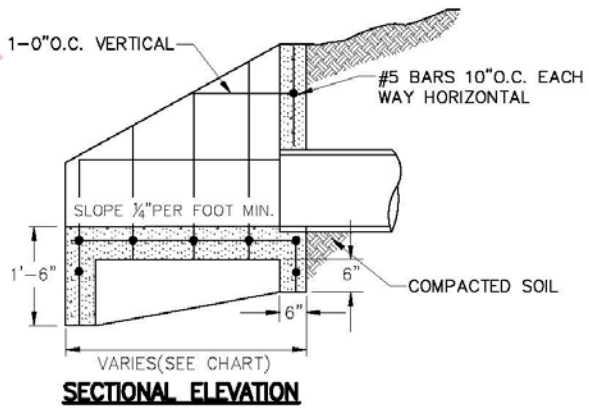

DRAFT

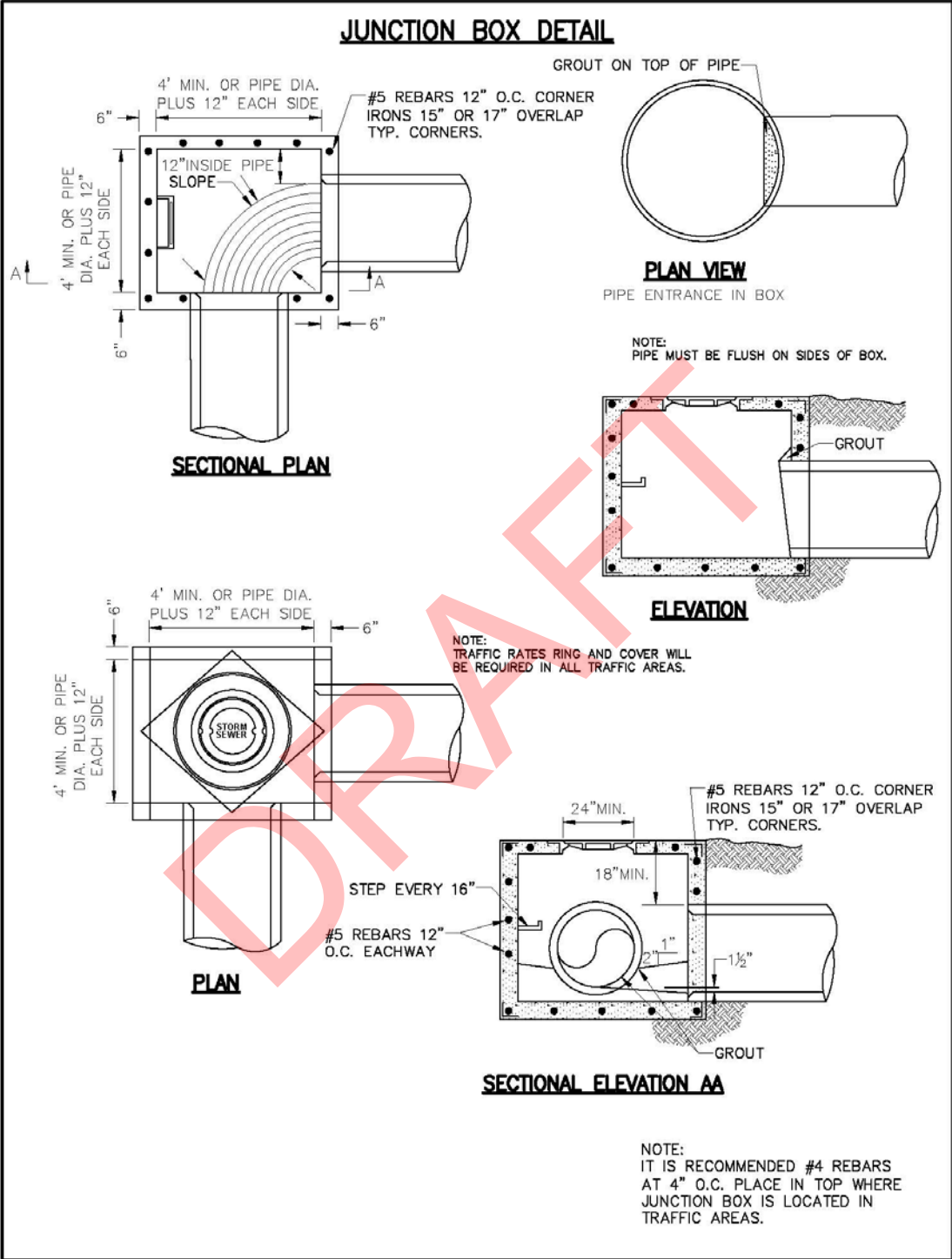

DRAFT

**AREA INLET DETAIL**

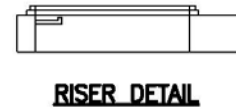
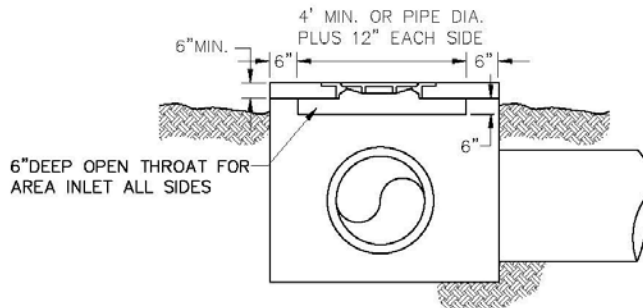

**AREA INLET ELEVATION**

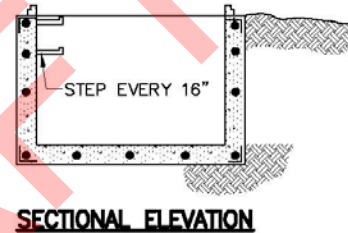
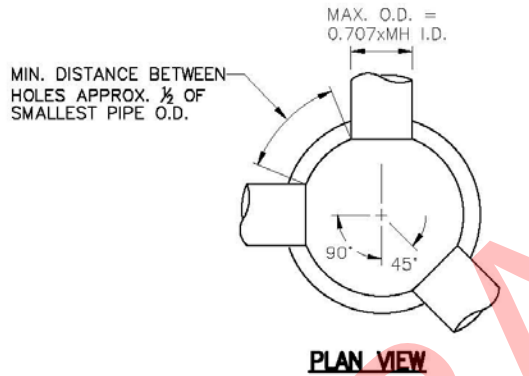

**SECTIONAL ELEVATION**

**PLAN VIEW**

PIPE DIA.	REQ'D OPENING*	MANHOLE DIA. (IN.)				
		48	60	72	84	96
15"	23"	85	>90	>90	>80	>90
18"	27"	83	>90	>90	>90	>90
21"	30"	72	>90	>90	>90	>90
24"	36"	55	85	>90	>90	>90
30"	42"	-	85	90	>90	>90
36"	48"	-	45	75	90	>90
42"	56"	-	-	50	70	90
48"	63"	-	-	15	45	70
54"	70"	-	-	-	30	56

\*OPENING=PIPE DIA.+(WALL THICKNESS x 2) + 3.5" FREE SPACE

NOTE:  
GUIDE SPECIFICATION FOR FLEXIBLE SLEEVE  
USE WITH PIPE TO MANHOLE CONNECTION.

MANHOLE DIA. (IN.)	MAX. PIPE SIZE O.D. (IN.)		
	FROM STRAIGHT THRU TO 45° DEFL.	IF 90° DEFL.	HOLE SIZE (IN.)
48	26.5	22.5	8-28
60	32.3	30.2	30-34
72	40.5	35.5	36-42

DRAFT

**RIPRAP DITCH SECTION**

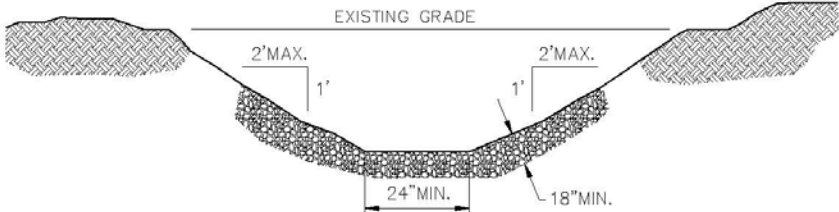

**NOTE:**

- 1. BOTTOM WIDTH IS DETERMINED BY ENGINEER.
- 2. A 3:1 SIDE SLOPE IS PREFERRED, BUT NO SLOPE CAN EXCEED 2:1.

PIPE SIZE	BOTTOM WIDTH MINIMUM
15 IN	2FT
18 IN	2FT
24 IN	3FT
30 IN	3FT
36 IN	4FT
42 IN	4FT
48 IN	5FT
54 IN	5FT
60 IN	6FT
72 IN	7FT

DRAFT

DRAFT



### HDPE PIPE INSTALLATION DETAIL

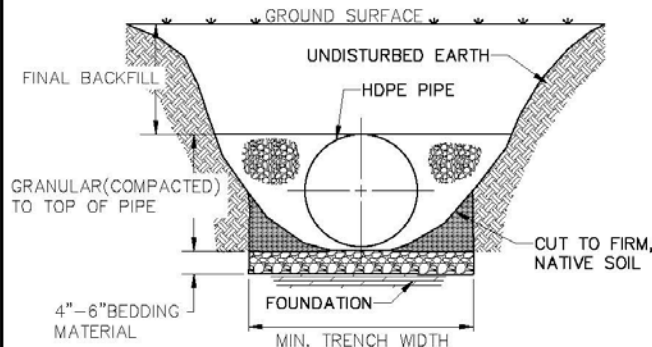

**TYPICAL OPEN DITCH CROSS-SECTION**

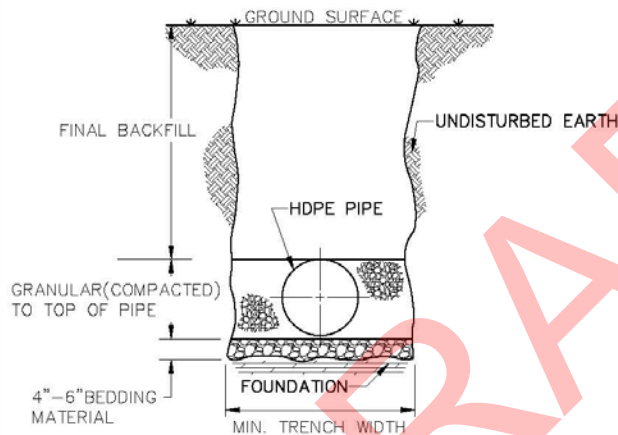

**TYPICAL TRENCH CROSS-SECTION**

UNLESS SPECIFIED BY THE ENGINEER, MINIMUM RECOMMENDED TRENCH WIDTH SHALL BE AS FOLLOWS:

NOMINAL DIAMETER (IN.)	MIN. TRENCH WIDTH (IN.)
15	34
18	39
24	48
30	56
36	64
42	72
48	80
60	96

#### NOTES

- BEDDING AND BACKFILL MATERIAL SHALL BE CLASS I MEETING ASTM D 2321. SEE DEFINITIONS BELOW.
- TO PREVENT MIGRATION OF FINES AND LOSS OF PIPE SUPPORT FOR INSTALLATIONS WHERE SIGNIFICANT GROUND-WATER FLOW IS ANTICIPATED, CLASS I BEDDING AND BACKFILL MUST BE USED AND THE ENTIRE PERIMETER OF THE ENCASEMENT SHALL BE WRAPPED WITH AN APPROVED GEOTEXTILE FABRIC.
- FOR INSTALLATIONS WHERE THE TRENCH BOTTOM IS UNSTABLE, UNDERCUT TO A DEPTH AS REQUIRED BY THE ENGINEER AND REPLACE WITH A SUITABLE BEDDING MATERIAL, PLACED IN 6-INCH LIFTS.
- ALL HIGH-DENSITY POLYETHYLENE (HDPE) PIPE USED FOR CULVERT AND STORMDRAIN APPLICATIONS SHALL CONFORM TO THE REQUIREMENTS OF AASHTO M294, TYPE S, CURRENT EDITION AND VERIFIED THROUGH THE PLASTIC PIPE INSTITUTE (PPI) THIRD PARTY CERTIFICATION PROGRAM. ALL HDPE PIPE DELIVERED AND USED SHALL BEAR THE THIRD PARTY ADMINISTERED PPI SEAL.
- INSTALLATIONS WHICH MEASURE OVER 15 FEET OF FILL FROM TOP OF PIPE TO FINISHED GRADE LEVEL ARE TO BE APPROVED BY CITY ENGINEER.

ASTM D 2321 MATERIAL DEFINITIONS:

CLASS I - ANGULAR CRUSHED STONE OR ROCK, DENSE OR OPEN GRADED WITH LITTLE TO NO FINES. (1/4" TO 1.5" IN SIZE). INCLUDED NOT LIMITED TO SIZES 5, 57, 67, 8, 9, 10, & 610.

DRAFT

**CURB & GUTTER DETAIL**

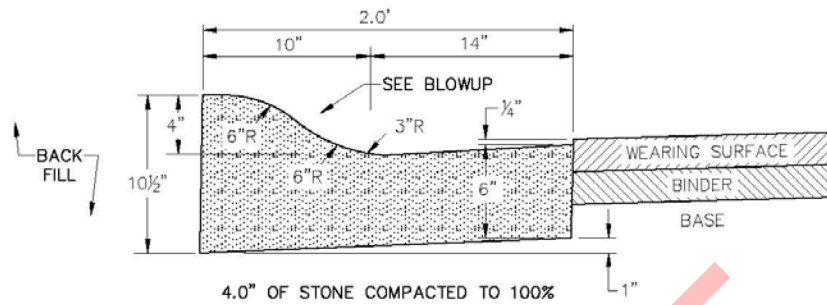

**ROLL CURB**

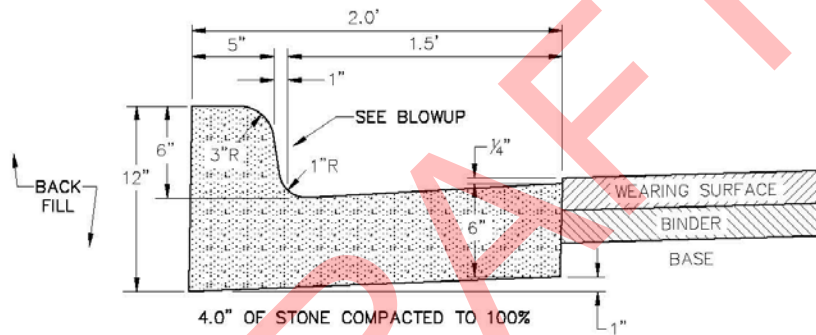

\*\*USE OF SPILL CURB MUST BE REVIEWED AND APPROVED PRIOR TO INSTALLATION

**CURB & GUTTER**

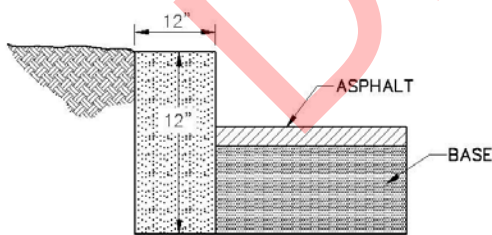

WELL COMPACTED SUBGRADE (IMPROVED)

**HEADER CURB**

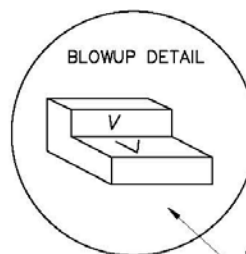

\*UTILITY MARKINGS SHOULD BE PLACES ON CURB FACE & FLAT (GUTTER).

DRAFT

**APPENDIX 6B**  
**STORMWATER STORAGE FACILITY**  
**OPERATION AND MAINTENANCE AGREEMENT**  
**(LEE COUNTY)**

DRAFT

DRAFT

STATE OF ALABAMA  
LEE COUNTY

STORMWATER STORAGE FACILITY OPERATION AND MAINTENANCE AGREEMENT

THIS AGREEMENT, made and entered into this the \_\_\_\_\_ day of \_\_\_\_\_,  
by and between The City of Phenix City, hereinafter referred to as City, and \_\_\_\_\_  
\_\_\_\_\_, hereinafter referred to as Owner;

WITNESSETH

THAT WHEREAS, Owner is this day accepting responsibility for perpetual care, operation, maintenance, and associated liabilities of the storm water storage facility installed on that certain real property known as \_\_\_\_\_, as described in the deed and as shown on the plat thereof recorded in the Deed Book \_\_\_\_\_, Page \_\_\_\_\_, and/or Plat Book \_\_\_\_\_, Page \_\_\_\_\_ Lee County Court House; and

WHEREAS, as part of construction of the development the City's Phase II Storm Water Ordinance required that a storm water storage facility be constructed; and

WHEREAS, the Owner accepts responsibility for maintenance of the storm water storage facility listed below as prescribed in the attached Operation and Maintenance Plan; and

WHEREAS, the Owner grants access to the City to inspect the storm water storage facility; and

WHEREAS, the Owner understands that this Agreement shall endure to the benefit of his successors in title, whomsoever they may be in the future.

NOW, THEREFORE, it is understood and agreed by and between the parties:

1. Maintenance of the storm water storage facility shall be the sole responsibility of the Owner.
2. The responsibility for maintenance of the storm water storage facility shall pass in the chain of title to the Owner's successor in interest.
3. Operation and maintenance will be in accordance with previously approved Operation and Maintenance Plan.
4. Access is granted to the City to carry out all provisions of the City's Phase II Storm Water Ordinance, including but not limited to inspections of the storm water storage facility.
5. The City will provide a copy of its inspection report to the Owner, and any required maintenance or remedial work identified in the report must be completed within 60 days.
6. The Owner will submit evidence that the required maintenance and/or remedial repairs identified during the City's inspection have been completed within 60 days of receipt of the inspection report.
7. Failure to follow the Operations and Maintenance Plan and/or complete necessary repairs identified during the City's inspection will result in enforcement actions.

DRAFT



Future communications in writing, from the City to the Owner, shall be sent to the Owner's address, as stated below.

In Witness Whereof, the parties have executed this Agreement the day and year above first written.

By: \_\_\_\_\_  
OWNER

\_\_\_\_\_  
GRANTOR'S SIGNATURE

\_\_\_\_\_  
ADDRESS

\_\_\_\_\_  
CITY, STATE

\_\_\_\_\_  
TELEPHONE NUMBER

I, \_\_\_\_\_, a Notary Public of said County and State, certify that \_\_\_\_\_ personally appeared before me this day and acknowledged that he/she is \_\_\_\_\_ of \_\_\_\_\_, an Alabama company and that by authority duly given and as the act of the \_\_\_\_\_ company, the foregoing instrument was signed in its name and by its \_\_\_\_\_, sealed with its corporate seal and/or attested by him/her as its \_\_\_\_\_.

Witness my hand and seal this \_\_\_\_\_ day of \_\_\_\_\_, \_\_\_\_\_.

\_\_\_\_\_  
Notary Public

(SEAL)

My Commission Expires: \_\_\_\_\_.

DRAFT

**APPENDIX 6C**

**SUBDIVISION STORMWATER STORAGE FACILITY  
OPERATION AND MAINTENANCE AGREEMENT  
(LEE COUNTY)**

DRAFT

DRAFT

**Subdivision Stormwater Storage Facility Operations & Maintenance Agreement**

This agreement made and entered into this \_\_\_\_\_ day of \_\_\_\_\_ 20\_\_\_\_, by and between the City of Phenix City, hereinafter referred to as CITY, and \_\_\_\_\_ hereinafter referred to as DEVELOPER;

**WITNESSETH:**

WHEREAS, the DEVELOPER intends to construct a development known as \_\_\_\_\_, located on lots \_\_\_\_\_, as shown on the plat thereof recorded in the Deed Book \_\_\_\_\_, Page \_\_\_\_\_, and/or Plat Book \_\_\_\_\_, Page \_\_\_\_\_ Lee County Court House, herein referred to as the DEVELOPMENT; and

WHEREAS, construction of the DEVELOPMENT requires, by the CITY, that the DEVELOPER construct a stormwater storage facility in accordance with the CITY's stormwater management requirements; and

WHEREAS, the stormwater management facility servicing the DEVELOPMENT is located on lot(s) \_\_\_\_\_, as described in the Deed Book \_\_\_\_\_, Page \_\_\_\_\_, and/or Plat Book \_\_\_\_\_, Page \_\_\_\_\_ County Court House, herein referred to as the PROPERTY; and

WHEREAS, the DEVELOPER intends to establish a Homeowner's Association which is primarily responsible for the maintenance of landscaping thereon, and maintenance of the stormwater storage facility within the PROPERTY. Operation and maintenance of the stormwater storage facility shall be in accordance with the previously approved Operation and Maintenance Plan; and

WHEREAS, the DEVELOPER understands that this Agreement shall inure to the benefits of his successors in title, whomsoever they may be in the future.

DRAFT

NOW THEREFORE, in consideration of the mutual covenants and agreements, IT IS AGREED, as follows:

1. Each lot in the DEVELOPMENT, and any future subdivision of lots within the DEVELOPMENT, shall have attached to it an equal and undividable ownership in the PROPERTY and each and every lot owner, including lots retained by the DEVELOPER, shall be considered the "OWNER" of the stormwater storage facility(s) located on the PROPERTY. Subject to the other terms of the agreement, the Homeowner's Association shall, as the agent of the OWNER, thereafter be primarily responsible for the landscaping and maintenance of the stormwater storage facility located on the PROPERTY. If the Homeowner's Association is never created, is not responsive, or is dissolved, then the OWNER shall be responsible for all obligations of this agreement.
2. The CITY is authorized to access the PROPERTY to inspect the storm water storage facility as necessary to ascertain that the practices are being maintained and operated in accordance with the approved stormwater management plan.
3. The CITY is authorized to perform the corrective actions identified in the annual stormwater storage facility inspections report if the OWNER or Homeowner's Association does not make the required corrections in the specified time period.
4. Each lot in the DEVELOPMENT, and any future subdivision of lots within the DEVELOPMENT, shall be jointly and severally liable for any expense or cost incurred by the CITY to preserve, maintain, or restore the stormwater storage facility, or landscaping located on the PROPERTY. The CITY shall be empowered, without notice of hearing, to levy a special assessment against each OWNER within the DEVELOPMENT, and any future subdivision of the lots within the DEVELOPMENT, and each and every OWNER agrees to pay for any such special assessment for expenses incurred by the CITY for the maintenance of stormwater facility(s) should they not be maintained by the OWNER or the Homeowner's Association.
5. DEVELOPER, OWNER, and Homeowner's Association agree to indemnify and hold harmless the CITY, its board members, employees, agents, and officers from any costs, damage, loss, claim, suit, liability or award which may arise, come, be brought or incurred or assessed because of the existence of, and action or failure to act with respect to the stormwater storage facility, and the drainage and utility easements on the PROPERTY or because of any adverse effect upon any person or property related or alleged to be related to the stormwater storage facility and drainage and utility easements. The CITY shall have the right to defend any such claim and DEVELOPER, OWNER, and Homeowner's Association shall reimburse the CITY for any and all costs and/or expenses, including but not limited to attorney's fees, which the CITY may incur as a result of such claims.
6. The rights and obligations created by this Agreement shall be covenants running within the DEVELOPMENT and future subdivision thereof and shall inure to the benefit of, and be binding upon, the parties, their heirs, personal representatives, successors and assigns.

DRAFT



In Witness Whereof, the parties have executed this Agreement the day and year above first written.

By: \_\_\_\_\_ (DEVELOPER)  
\_\_\_\_\_  
\_\_\_\_\_  
\_\_\_\_\_  
\_\_\_\_\_  
\_\_\_\_\_ (TELEPHONE NUMBER)

CITY OF PHENIX CITY,  
ALABAMA

By: \_\_\_\_\_  
Its: \_\_\_\_\_

STATE OF ALABAMA  
LEE COUNTY

I, the undersigned authority, a Notary Public in and for said County, in said State, hereby certify that

\_\_\_\_\_, whose name is signed to the foregoing instrument, on behalf of the Developer, and who is known to me, acknowledged before me on this date that, being informed of the contents of the foregoing document, he/she executed the same voluntarily on the day the same bears date.

Given under my hand and official seal this the \_\_\_\_\_ day of \_\_\_\_\_, 20\_\_\_\_.

\_\_\_\_\_  
Notary Public

Commission Expires \_\_\_\_\_

DRAFT

STATE OF ALABAMA

LEE COUNTY

I, the undersigned authority, a Notary Public in and for said County, in said State, hereby certify that

\_\_\_\_\_, whose name is signed to the foregoing instrument, on behalf of the City of Phenix City, Alabama, and who is known to me, acknowledged before me on this date that, being informed of the contents of the foregoing document, he/she executed the same voluntarily on the day the same bears date.

Given under my hand and official seal this the \_\_\_\_\_ day of \_\_\_\_\_, 20\_\_\_\_.

\_\_\_\_\_  
Notary Public

Commission Expires \_\_\_\_\_

DRAFT

DRAFT

**APPENDIX 6D**  
**STORMWATER STORAGE FACILITY**  
**OPERATION AND MAINTENANCE AGREEMENTS**  
**(RUSSELL COUNTY)**

DRAFT

DRAFT

STATE OF ALABAMA  
RUSSELL COUNTY

STORMWATER STORAGE FACILITY OPERATION AND MAINTENANCE AGREEMENT

THIS AGREEMENT, made and entered into this the \_\_\_\_\_ day of \_\_\_\_\_,  
by and between The City of Phenix City, hereinafter referred to as City, and \_\_\_\_\_  
\_\_\_\_\_, hereinafter referred to as Owner;

WITNESSETH

THAT WHEREAS, Owner is this day accepting responsibility for perpetual care, operation, maintenance, and associated liabilities of the storm water storage facility installed on that certain real property known as \_\_\_\_\_, as described in the deed and as shown on the plat thereof recorded in the Deed Book \_\_\_\_\_, Page \_\_\_\_\_, and/or Plat Book \_\_\_\_\_, Page \_\_\_\_\_ Russell County Court House; and

WHEREAS, as part of construction of the development the City's Phase II Storm Water Ordinance required that a storm water storage facility be constructed; and

WHEREAS, the Owner accepts responsibility for maintenance of the storm water storage facility listed below as prescribed in the attached Operation and Maintenance Plan; and

WHEREAS, the Owner grants access to the City to inspect the storm water storage facility; and

WHEREAS, the Owner understands that this Agreement shall endure to the benefit of his successors in title, whomsoever they may be in the future.

NOW, THEREFORE, it is understood and agreed by and between the parties:

1. Maintenance of the storm water storage facility shall be the sole responsibility of the Owner.
2. The responsibility for maintenance of the storm water storage facility shall pass in the chain of title to the Owner's successor in interest.
3. Operation and maintenance will be in accordance with previously approved Operation and Maintenance Plan.
4. Access is granted to the City to carry out all provisions of the City's Phase II Storm Water Ordinance, including but not limited to inspections of the storm water storage facility.
5. The City will provide a copy of its inspection report to the Owner, and any required maintenance or remedial work identified in the report must be completed within 60 days.
6. The Owner will submit evidence that the required maintenance and/or remedial repairs identified during the City's inspection have been completed within 60 days of receipt of the inspection report.
7. Failure to follow the Operations and Maintenance Plan and/or complete necessary repairs identified during the City's inspection will result in enforcement actions.

DRAFT



Future communications in writing, from the City to the Owner, shall be sent to the Owner's address, as stated below.

In Witness Whereof, the parties have executed this Agreement the day and year above first written.

By: \_\_\_\_\_  
OWNER

\_\_\_\_\_  
GRANTOR'S SIGNATURE

\_\_\_\_\_  
ADDRESS

\_\_\_\_\_  
CITY, STATE

\_\_\_\_\_  
TELEPHONE NUMBER

I, \_\_\_\_\_, a Notary Public of said County and State, certify that \_\_\_\_\_ personally appeared before me this day and acknowledged that he/she is \_\_\_\_\_ of \_\_\_\_\_, an Alabama company and that by authority duly given and as the act of the \_\_\_\_\_ company, the foregoing instrument was signed in its name and by its \_\_\_\_\_, sealed with its corporate seal and/or attested by him/her as its \_\_\_\_\_.

Witness my hand and seal this \_\_\_\_\_ day of \_\_\_\_\_, \_\_\_\_\_.

\_\_\_\_\_  
Notary Public

(SEAL)

My Commission Expires: \_\_\_\_\_.

DRAFT

**APPENDIX 6E**

**SUBDIVISION STORMWATER STORAGE FACILITY  
OPERATION AND MAINTENANCE AGREEMENT  
(RUSSELL COUNTY)**

DRAFT

DRAFT

**Subdivision Stormwater Storage Facility Operations & Maintenance Agreement**

This agreement made and entered into this \_\_\_\_\_ day of \_\_\_\_\_ 20\_\_\_\_, by and between the City of Phenix City, hereinafter referred to as CITY, and \_\_\_\_\_ hereinafter referred to as DEVELOPER;

**WITNESSETH:**

WHEREAS, the DEVELOPER intends to construct a development known as \_\_\_\_\_, located on lots \_\_\_\_\_, as shown on the plat thereof recorded in the Deed Book \_\_\_\_\_, Page \_\_\_\_\_, and/or Plat Book \_\_\_\_\_, Page \_\_\_\_\_ Russell County Court House, herein referred to as the DEVELOPMENT; and

WHEREAS, construction of the DEVELOPMENT requires, by the CITY, that the DEVELOPER construct a stormwater storage facility in accordance with the CITY's stormwater management requirements; and

WHEREAS, the stormwater management facility servicing the DEVELOPMENT is located on lot(s) \_\_\_\_\_, as described in the Deed Book \_\_\_\_\_, Page \_\_\_\_\_, and/or Plat Book \_\_\_\_\_, Page \_\_\_\_\_ County Court House, herein referred to as the PROPERTY; and

WHEREAS, the DEVELOPER intends to establish a Homeowner's Association which is primarily responsible for the maintenance of landscaping thereon, and maintenance of the stormwater storage facility within the PROPERTY. Operation and maintenance of the stormwater storage facility shall be in accordance with the previously approved Operation and Maintenance Plan; and

WHEREAS, the DEVELOPER understands that this Agreement shall inure to the benefits of his successors in title, whomsoever they may be in the future.

DRAFT

NOW THEREFORE, in consideration of the mutual covenants and agreements, IT IS AGREED, as follows:

1. Each lot in the DEVELOPMENT, and any future subdivision of lots within the DEVELOPMENT, shall have attached to it an equal and undividable ownership in the PROPERTY and each and every lot owner, including lots retained by the DEVELOPER, shall be considered the "OWNER" of the stormwater storage facility(s) located on the PROPERTY. Subject to the other terms of the agreement, the Homeowner's Association shall, as the agent of the OWNER, thereafter be primarily responsible for the landscaping and maintenance of the stormwater storage facility located on the PROPERTY. If the Homeowner's Association is never created, is not responsive, or is dissolved, then the OWNER shall be responsible for all obligations of this agreement.
2. The CITY is authorized to access the PROPERTY to inspect the storm water storage facility as necessary to ascertain that the practices are being maintained and operated in accordance with the approved stormwater management plan.
3. The CITY is authorized to perform the corrective actions identified in the annual stormwater storage facility inspections report if the OWNER or Homeowner's Association does not make the required corrections in the specified time period.
4. Each lot in the DEVELOPMENT, and any future subdivision of lots within the DEVELOPMENT, shall be jointly and severally liable for any expense or cost incurred by the CITY to preserve, maintain, or restore the stormwater storage facility, or landscaping located on the PROPERTY. The CITY shall be empowered, without notice of hearing, to levy a special assessment against each OWNER within the DEVELOPMENT, and any future subdivision of the lots within the DEVELOPMENT, and each and every OWNER agrees to pay for any such special assessment for expenses incurred by the CITY for the maintenance of stormwater facility(s) should they not be maintained by the OWNER or the Homeowner's Association.
5. DEVELOPER, OWNER, and Homeowner's Association agree to indemnify and hold harmless the CITY, its board members, employees, agents, and officers from any costs, damage, loss, claim, suit, liability or award which may arise, come, be brought or incurred or assessed because of the existence of, and action or failure to act with respect to the stormwater storage facility, and the drainage and utility easements on the PROPERTY or because of any adverse effect upon any person or property related or alleged to be related to the stormwater storage facility and drainage and utility easements. The CITY shall have the right to defend any such claim and DEVELOPER, OWNER, and Homeowner's Association shall reimburse the CITY for any and all costs and/or expenses, including but not limited to attorney's fees, which the CITY may incur as a result of such claims.
6. The rights and obligations created by this Agreement shall be covenants running within the DEVELOPMENT and future subdivision thereof and shall inure to the benefit of, and be binding upon, the parties, their heirs, personal representatives, successors and assigns.

DRAFT



In Witness Whereof, the parties have executed this Agreement the day and year above first written.

By: \_\_\_\_\_ (DEVELOPER)  
\_\_\_\_\_  
\_\_\_\_\_  
\_\_\_\_\_  
\_\_\_\_\_  
\_\_\_\_\_  
\_\_\_\_\_  
\_\_\_\_\_  
\_\_\_\_\_  
\_\_\_\_\_ (GRANTOR'S SIGNATURE)  
\_\_\_\_\_  
\_\_\_\_\_  
\_\_\_\_\_  
\_\_\_\_\_  
\_\_\_\_\_  
\_\_\_\_\_  
\_\_\_\_\_ (ADDRESS)  
\_\_\_\_\_  
\_\_\_\_\_  
\_\_\_\_\_  
\_\_\_\_\_  
\_\_\_\_\_  
\_\_\_\_\_  
\_\_\_\_\_  
\_\_\_\_\_  
\_\_\_\_\_ (CITY, STATE)  
\_\_\_\_\_  
\_\_\_\_\_  
\_\_\_\_\_  
\_\_\_\_\_  
\_\_\_\_\_  
\_\_\_\_\_  
\_\_\_\_\_  
\_\_\_\_\_  
\_\_\_\_\_ (TELEPHONE NUMBER)

CITY OF PHENIX CITY,  
ALABAMA

By: \_\_\_\_\_

Its: \_\_\_\_\_

STATE OF ALABAMA

RUSSELL COUNTY

I, the undersigned authority, a Notary Public in and for said County, in said State, hereby certify that

\_\_\_\_\_, whose name is signed to the foregoing instrument, on behalf of the Developer, and who is known to me, acknowledged before me on this date that, being informed of the contents of the foregoing document, he/she executed the same voluntarily on the day the same bears date.

Given under my hand and official seal this the \_\_\_\_\_ day of \_\_\_\_\_, 20\_\_\_\_.

\_\_\_\_\_  
Notary Public

Commission Expires \_\_\_\_\_

DRAFT

STATE OF ALABAMA

RUSSELL COUNTY

I, the undersigned authority, a Notary Public in and for said County, in said State, hereby certify that

\_\_\_\_\_, whose name is signed to the foregoing instrument, on behalf of the City of Phenix City, Alabama, and who is known to me, acknowledged before me on this date that, being informed of the contents of the foregoing document, he/she executed the same voluntarily on the day the same bears date.

Given under my hand and official seal this the \_\_\_\_\_ day of \_\_\_\_\_, 20\_\_\_\_.

\_\_\_\_\_  
Notary Public

Commission Expires \_\_\_\_\_

DRAFT

DRAFT

**APPENDIX 6F**  
**STORMWATER STORAGE FACILITY**  
**FINAL CERTIFICATION FORM**

DRAFT

DRAFT

## Stormwater Storage Facility Final Certification Form

Engineering and Public Works Department  
 1206 7<sup>th</sup> Avenue, 2<sup>nd</sup> Floor  
 Phenix City, AL 36867  
[EngineeringPW@phenixcityal.us](mailto:EngineeringPW@phenixcityal.us)

Project Name: \_\_\_\_\_

**Storage Volume Summary:**

	2-Year	5-Year	10-Year	25-Year	100-Year
Design Volume					
As-Built Volume					

**Outlet Device Elevation Summary:**

	Size and Description Information		Design Elevation	As-Built Elevation
	Design	As-Built		
Outlet Device #1				
Outlet Device #2				
Outlet Device #3				
Outlet Device #4				
Outlet Device #5				
Emergency Spillway				
Bottom of Pond				

*(As necessary, please provide any comments or other information necessary to accurately describe the as-built storage facility conditions in a separate Memorandum and attach to this form)*

By placing my professional stamp and signature on this form, I certify that this storage facility is constructed in accordance with the approved design on file with the City of Phenix City and that all temporary sediment storage components have been removed. I further certify that all drainage areas designed to be attenuated in the storage facility in fact do drain to this facility and the outlet peak discharge rates are equal to or less than the peak discharge rates as approved for the development.

Signed: \_\_\_\_\_

Seal:

Date: \_\_\_\_\_

DRAFT



## 7.0 UTILITIES (POTABLE WATER AND SANITARY SEWER)

### 7.1 GENERAL

The purpose of this section of the Manual is to provide requirements for the design and construction of potable water and sanitary sewer infrastructure that is maintained by the City of Phenix City.

#### 7.1.1 Potable Water and Sanitary Sewer Locations

Information regarding location of potable water and sanitary sewer components are covered in Section 4.5.2 of this Manual. The Project Developer and/or property Owner shall coordinate the location of sanitary sewer laterals and water meters with planned locations for driveways to avoid these utilities being placed in driveways, resulting in future maintenance issues. In general, the Utility Department requires the location of sanitary sewer laterals and water meters to be placed a minimum of 5-feet from any driveway or portion of the driveway including the radius where the driveway connects to the road. Additional information regarding the placement of utilities near driveways may be found in Section 4.2.1.7 of this Manual.

#### 7.1.2 Required Pre-Development Meeting

During the early stages of a project's development, the Project Developer and the Developer's Engineer shall meet with the City Engineer, Utility Engineer, Building Official, and Fire Code Official, or their representatives, for a pre-development meeting to determine the availability and capacity of potable water and sanitary sewer service in the project area. Preliminary estimations of the anticipated potable water and sanitary sewer demands shall be available for review. Should insufficient infrastructure or pressure, in size and/or location, exist to serve the proposed project, the Project Developer shall be responsible for all costs associated with the design and construction, subject to approval by the City, of the needed improvements.

The Project Developer shall submit layout drawings and details of proposed potable water and sanitary sewers prepared by a registered engineer licensed to practice in the State of Alabama, which indicate the size and location of all potable water and sanitary sewer infrastructure components. In addition, the engineer shall provide infrastructure capacity calculations and water system loop analysis of the proposed infrastructure. Drawings, calculations, and other required materials shall conform to the requirements specified in the Phenix City Subdivision Regulations. This information is subject to review and approval by the City's Utility Department and City Engineer.

#### 7.1.3 City Acceptance of Potable Water and Sanitary Sewer Infrastructure

Upon completion of the proposed development, and prior to acceptance for

maintenance by the City, the Project Developer shall present AS-BUILT drawings, generated from a post-construction field survey, indicating the location, size, and material of all water and sanitary sewer infrastructure. AS-BUILT drawings shall be printed on minimum 22" X 34" paper and prepared at such a scale that all information is easily readable. In addition, all approved shop drawings, Operations and Maintenance Manuals and warranties for any pumping station, water booster station, or other mechanical devices used in the project shall be bound and submitted to the City.

Construction plans for utility extensions must be reviewed and approved by the City Engineering Department prior to construction. After the project is successfully constructed, all review and approval forms are completed, and AS-BUILT drawing information has been reviewed and approved by the City's Utility Department, the project may be accepted by the City for maintenance.

## 7.2 POTABLE WATER

When a Public Water Supply is reasonably accessible as determined by the City and within the City's Utility Department's jurisdiction, the Project Developer shall construct a water supply system in accordance with the requirements herein. Projects outside of the City's Utility Department jurisdiction shall be governed by the local water system providing the water service. If the City receives a statement from an adjoining utility jurisdiction stating that said jurisdiction cannot provide water and/or sanitary sewer service to an area, the City of Phenix City shall consider providing water and/or sanitary sewer service to said area.

### 7.2.1 Potable Water Design Criteria

Each potable water line shall be sized based on generally accepted engineering practices and the requirements stated herein and shall provide the anticipated domestic water demand plus the anticipated fire flow while maintaining a minimum residual pressure of 25 pounds per square inch (psi).

The minimum size for potable water lines shall be limited to 8-inches in diameter unless specially approved by the Utility Department. Potable water lines shall be otherwise sized for the anticipated domestic water demand plus anticipated fire flow with a maximum velocity of 6 feet per second.

Residential water demand shall be calculated based on an average day demand of 100 gallons per capita/day. Commercial and multifamily residential water demands shall be based on the average day demands as specified in Table 7.1, or as approved by the Utility Department.

The layout of the potable water system shall be looped as directed by the Utilities Department with each intersecting line valved to facilitate isolating of the water line for maintenance with as little disruption to remaining customers as possible. Water system

valves shall be accessible to Utility Department personnel and located on as-built drawings with swing ties to permanent structures.

Dead end potable water lines shall be provided with a blow-off assembly at the end of such line and positioned such that discharged water does not present an erosion hazard or cause damage to adjacent properties. The blow-off assembly installation shall conform to the standard details shown in Appendix 7B.

### 7.2.2 Potable Water Required

Each building or lot established for a future building shall have established a potable water service consisting of a copper service line from the potable water main to the meter, a meter, backflow preventer and, if required, a pressure reducing valve. The minimum sizes for new potable water services shall be 1-inch copper, a ¾-inch water meter, ¾-inch backflow preventer and meter box set in the right-of-way, except where, due to physical obstructions (other utilities, pavement, etc.) it is not possible, in which case the meter shall be set on private property as close to the right-of-way as practicable when the property owner grants an easement to the City which is at least 5-feet around the meter box/vault and extends to the right of way line. Installation shall conform to the standard details shown in Appendix 7B. Potable water services for commercial and industrial establishments shall be sized for the desired water flow rate by the Developer's engineer and approved by the City's Utility Department. The installation of commercial and industrial potable water services shall be coordinated with the City's Utility Department.

## 7.0 UTILITIES (POTABLE WATER AND SANITARY SEWER)

**TABLE 7.1 COMMERCIAL BUILDING WATER USAGE**

COMMERCIAL BUILDING	UNITS	AVERAGE USE	PEAK USE
Hotels	Gals. /Day/SF	30	50
Motels	Gals. /Day/SF	25	175
Barber Shops	Gals. /Day/barber chair	55	390
Beauty Shops	Gals. /Day/station	270	1,070
Restaurants	Gals. /Day/seat	25	165
Night Clubs	Gals. /Day/ person served	1.5	1.5
Hospitals	Gals. /Day/bed	350	910
Nursing Homes	Gals. /Day/bed	130	425
Medical Offices	Gals. /Day/SF	70	560
Laundry	Gals. /Day/SF	30	175
Laundromats	Gals. /Day/SF	245	730
Retail Space	Gals. /Day/SF of sales floor	12	30
Elementary Schools	Gals. /Day/student	5	50
High Schools	Gals. /Day/student	7	120
Bus-Rail Depot	Gals. /Day/SF	375	2,800
Car Washes	Gals. /Day/SF	540	3,540
Churches	Gals. /Day/member	0.5	5
Golf-swim clubs	Gals. /Day/member	22	30
Bowling Alleys	Gals. /Day/alley	135	135
Residential Colleges	Gals. /Day/student	110	250
New Office Buildings	Gals. /Day/SF	10	60
Old Office Buildings	Gals. /Day/SF	15	40
Theaters	Gals. /Day/seat	3.5	3.5
Service Stations	Gals. /Day/Inside SF	30	3,540
Apartments	Gals. /Day/unit	215	435
Fast Food Restaurants	Gals. /Day/establishment	1,800	5,365

*Adapted from: Water Resources Engineering, 1<sup>st</sup> Edition, Larry W. Mays, John Wiley & Sons, Inc. 2001 (Table 11.1.4)*

### 7.2.3 Potable Water Specifications and Details

Additional information regarding the required materials of construction and installation requirements may be found in the most current version of the Phenix City Utilities Department's Water Distribution Specifications (see Appendix 7A) and standard details for water line construction (see Appendix 7B).

## 7.3 FIRE DEMANDS

The water system demand for fire protection shall conform to the latest edition of the International Fire Code. The information below contains excerpts from the International Fire Code and is presented here for convenience and as guidance in providing a sufficient water source.

**7.3.1 Residential Developments**

The fire flow calculation area for one and two-family homes, Group R-3 and R-4 and townhouses shall be the total floor area of all floors within the exterior walls and under the horizontal projections of the roof area. The fire flow calculation area for buildings of Type 1A and Type 1B shall be the area of the three largest successive floors.

The required minimum fire flow requirements for one and two-family dwellings, Group R-3 and R-4 buildings and townhouses not exceeding shall conform to Table 7.2.

**Table 7.2 Required Fire Flow for one and two-family dwellings, Group R-3 and R-4 buildings and townhouses**

<b>Fire Flow Calculation Area (square feet)</b>	<b>Automatic Sprinkler System (Design Standard)</b>	<b>Minimum Fire Flow (gallons per minute)</b>	<b>Flow Duration (hours)</b>
0-3,600	No automatic sprinkler system	1,000	1
3,601 and greater	No automatic sprinkler system	Value in Table 7.4	Duration in Table 7.4 at the required fire flow rate
0-3,600	Section 903.3.1.3 of the International Fire Code or P2904 of the International Residential Code	500	½
3,601 and greater	Section 903.3.1.3 of the International Fire Code or P2904 of the International Residential Code	½ value in Table 7.4	1

Minimum fire flow requirements may be increased at the discretion of the Phenix City Fire Code Official in accordance with the most recent Fire Code adopted by the City.

**7.3.2 Fire Hydrant Requirements**

Fire hydrants shall be placed and positioned for easy access and be spaced to provide a maximum of a 500-foot fire hose lay from each residence or structure or in accordance with Table 7.3. A 3-foot minimum clear space shall be maintained around the circumference of each fire hydrant, unless otherwise approved by the Fire Department. Fire hydrant installation shall conform to the standard details in Appendix 7B.

The minimum potable water size serving a fire hydrant shall be 6-inches in diameter.

**Table 7.3 Required Number and Spacing of Fire Hydrants**

<b>Fire Flow Requirement (gpm)</b>	<b>Minimum Number of Hydrants</b>	<b>Average Spacing Between Hydrants<sup>a,b,c,f,g</sup> (feet)</b>	<b>Maximum Distance from any point on Street or Road Frontage to a Hydrant<sup>d,f,g</sup> (feet)</b>
1,750 or less	1	500	250
1,750 – 2,250	2	450	225
2,251 – 2,750	3	450	225
2,751 – 3,250	3	400	225
3,251 – 4,000	4	350	210
4,001 – 5,000	5	300	180
5,001 – 5,500	6	300	180
5,501 – 6,000	6	250	150
6,001 – 7,000	7	250	150
7,001 or more	8 or more <sup>e</sup>	200	120

a. Reduce by 100 feet for dead-end streets or roads.

b. Where streets are provided with median dividers that cannot be crossed by fire fighters pulling hose lines, or where arterial streets are provided with four or more traffic lanes and have a traffic count of more than 30,000 vehicles per day, hydrant spacing shall average 500 feet on each side of the street and be arranged on an alternating basis.

c. Where new water mains are extended along streets where hydrants are needed for protection of structures or similar fire problems, fire hydrants shall be provided at spacing not to exceed 1,000 feet to provide for transportation hazards.

d. Reduce by 50 feet for dead-end streets or roads.

e. One hydrant for each 1,000 gallons per minute or fraction thereof.

f. A 50 percent spacing increase shall be permitted where the building is equipped throughout with an approved automatic sprinklers system in accordance with Section 903.3.1.1 of the International Fire Code.

g. A 25 percent spacing increase shall be permitted where the building is equipped throughout with an approved automatic sprinkler system in accordance with Section 903.3.1.2 or 9.3.3.1.3 of the International Fire Code or Section P2904 of the International Fire Code.

h. The fire code official is authorized to modify the location, number and distribution of fire hydrants based on site-specific constraints and hazards.

### **7.3.3 Sprinklers**

Buildings equipped with a sprinkler system shall also be equipped with a double check backflow preventer enclosed in a concrete vault. The double check backflow preventer and standpipe assembly shall conform to the standard details in Appendix 7B. An additional fire hydrant shall be provided within 100-feet of the fire department connection. Vaults may not be located within the City’s ROW unless approved by the City Engineer.

### **7.3.4 Commercial and Industrial Fire Demands**

The water system demand for fire protection on Commercial or Industrial usage and in accordance with Types IA, IB, IIA, IIIA, IV, V-A, IIB, IIIB and V-B shall conform to Table 7.4 and Table 7.5.

**7.0 UTILITIES (POTABLE WATER AND SANITARY SEWER)**

**Table 7.4 Fire Flow Requirements for Commercial and Industrial Buildings**

Fire Flow Calculation Area (square feet)					Fire Flow (gpm) <sup>b</sup>	Flow Duration (hours)
Type IA and IB <sup>a</sup>	Type IIA and IIIA <sup>a</sup>	Type IV and V-A <sup>a</sup>	Type IIB and IIIB <sup>a</sup>	Type V-B <sup>a</sup>		
0-22,700	0-12,700	0-8,200	0-5,900	0-3,600	1,500	2
22,701-30,200	12,701-17,000	8,201-10,900	5,901-7,900	3,601-4,800	1,750	
30,201-38,700	17,001-21,800	10,901-12,900	7,901-9,800	4,801-6,200	2,000	
38,701-48,300	21,801-24,200	12,901-17,400	9,801-12,600	6,201-7,700	2,250	
48,301-59,000	24,201-33,200	17,401-21,300	12,601-15,400	7,701-9,400	2500	
59,001-70,900	33,201-39,700	21,301-25,500	15,401-18,400	9,401-11,300	2,750	
70,901-83,700	39,701-47,100	25,501-30,100	18,401-21,800	11,301-13,400	3,000	3
83,701-97,700	47,101-54,900	30,101-35,200	21,801-25,900	13,401-15,600	3,250	
97,701-112,700	54,901-63,400	35,201-40,600	25,901-29,300	15,601-18,000	3,500	
112,701-128,700	63,401-72,400	40,601-46,400	29,301-33,500	18,001-20,600	3,750	
128,701-145,900	72,401-82,100	46,401-52,500	33,501-37,900	20,601-23,300	4,000	4
145,901-164,200	82,101-92,400	52,501-59,100	37,901-42,700	23,301-26,300	4,250	
164,201-183,400	92,401-103,100	59,101-66,000	42,701-47,700	26,301-29,300	4,500	
183,401-203,700	103,101-114,600	66,001-73,300	47,701-53,000	29,301-32,600	4,750	
203,701-225,200	114,601-126,700	73,301-81,100	53,001-58,600	32,601-36,000	5,000	
225,201-247,700	126,701-139,400	81,101-89,200	58,601-65,400	36,001-39,600	5,250	
247,701-271,200	139,401-152,600	89,201-97,700	65,401-70,600	39,601-43,400	5,500	4
271,201-295,900	152,601-166,500	97,701-106,500	70,601-77,000	43,401-47,400	5,750	
295,901 or greater	166,501 or greater	106,501-115,800	77,001-83,700	47,401-51,500	6,000	
---	---	115,801-	83,701-	51,501-	6,250	

## 7.0 UTILITIES (POTABLE WATER AND SANITARY SEWER)

		125,500	90,600	55,700	
---	---	125,501- 135,500	90,601- 97,900	55,701- 60,200	6,500
---	---	135,501- 145,800	97,601- 106,800	60,201- 64,800	6,750
---	---	145,801- 156,700	106,801- 113,200	64,801- 69,600	7,000
---	---	156,701- 167,900	113,201- 121,300	69,601- 74,600	7,250
---	---	167,901- 179,400	121,301- 129,600	74,601- 79,800	7,500
---	---	179,401- 191,400	129,601- 138,300	79,801- 85,100	7,750
---	---	191,401 or greater	138,301 or greater	85,101 or greater	8,000

a. Construction Types are in accordance with the International Building Code.

b. Measured at 20 psi residual pressure

**Table 7.5 Required Fire Flow for Buildings other than One and Two Family Dwellings, Group R-3 and R-4 Buildings and Townhouses**

Automatic Sprinkler System (Design Standard)	Minimum Fire Flow (gallons per minute)	Flow Duration (hours)
No Automatic Sprinkler System	Value in Table 7.4	Duration in Table 7.4
Section 903.3.1.1 of the International Fire Code	25% of the value in Table 7.4 <sup>a</sup>	Duration in Table 7.4 at the reduced flow rate
Section 903.3.1.2 of the International Fire Code	25% of the value in Table 7.4 <sup>b</sup>	Duration in Table 7.4 at the reduced flow rate

a. The reduced fire flow shall not be less than 1,000 gallons per minute.

b. The reduced fire flow shall not be less than 1,500 gallons per minute.

## 7.4 SANITARY SEWER

When public sanitary sewers are reasonably accessible as determined by the City and within the City's Utility Department's jurisdiction, the Project Developer shall construct sanitary sewer infrastructure in accordance with the requirements herein for treatment at the City's wastewater treatment facility. Properties within the City's Utility Department jurisdiction and within 200 feet of a public sewer that can be reached with gravity flow, shall be required to connect to the public sewer in accordance with the Sanitary Sewer Use Ordinance as stated in the Phenix City Code, Chapter 82, Article III, Division 1. Projects outside of the City's Utility



Department jurisdiction shall be governed by the local sanitary sewer system providing treatment of the sanitary waste.

### **7.4.1 Projects Not Reasonably Accessible to Sewer**

Should the project area reside in a location that existing sanitary sewer infrastructure is not reasonably accessible and will be residential in nature, the Project Developer may elect to have each planned residence served by individual on-site sewage systems. The permitting, design and construction of individual on-site sewage systems and associated leaching field shall conform to regulations established by the Alabama Board of Health for Onsite Sewage Treatment and Disposal and the local County Health Department. Future maintenance of the individual on-site sewage system and leach field shall be the responsibility of the individual homeowner.

### **7.4.2 Sanitary Sewer Design**

Sanitary sewer infrastructure shall be designed and sized based on generally accepted engineering practices and the requirements stated herein. Main sewers, pumping stations and associated force mains shall be sized to accommodate the proposed development and future commercial, residential and industrial flows within the drainage basin. Sanitary sewer infrastructure shall be designed to carry the sewer flow for the estimated ultimate tributary population. Table 7.6 provides typical sanitary sewer flow rates for various types of facilities. These flow rates should be used in the calculation of sanitary sewer flows unless alternate rates are provided by the design engineer and approved by the City Utility Department.

### **7.4.3 Sanitary Sewer Specifications and Standard Details**

Sanitary sewers shall have a minimum diameter of 8-inches, unless otherwise approved by the City's Utility Department, and be sized to transmit the peak flow of the contributing area at a minimum velocity of 2 feet per second. Sanitary sewers shall be constructed of ductile iron pipe, Class 350, or PVC, SDR 35 or SDR 26 pipe. Spacing of manholes shall not exceed 400-feet. Required material and installation information is shown in the most current version of the Phenix City Utilities Department's Sanitary Sewer Specifications (see Appendix 7C) and the standard details (see Appendix 7D).

## 7.0 UTILITIES (POTABLE WATER AND SANITARY SEWER)

**Table 7.6 Base Flow Rates Based on Type of Facility**

Type of Facility	Base Flow Rate (gallons per day)	Unit
Bar, Tavern	3	per customer
	13	per employee
Barber Shop/Beauty Salon	333	per chair
Church (not including food service or day schools)	5	per seat
Coffee Shop	6	per customer
	10	per employee
Coin Laundries	400	per machine
Commercial Laundries	550	per machine
Commercial/Mercantile Building	75	per 1000 square feet
Country Club	100	per resident member
	13	per employee
Hospitals	165	per bed
Industrial/Warehouse (not including food service)	13	per employee
Nursing Home	125	per bed
Motel/Hotel	100	per room
Offices (not including food service)	175	per 1000 square feet
Police/Fire Station (with food service)	75	per resident employee
Police/Fire Station (without food service)	25	per non-resident employee
Residence, single family	200	per house
Residence, multi-family (including apartments)	200	per unit
Restaurant/Coffee Shop/Fast Food	55	per seat
School (with cafeteria)	12	per student
School (with cafeteria and gym)	15	per student
School (with cafeteria, gym and food service)	25	per student
Service Station	10	per car
Shopping Center (not including food service)	100	per 1000 square feet
Theater	3	per seat

Peak flowrates shall be used to size sanitary sewer mains, pumping stations and force mains. For residential development, a peaking factor of 2.5 times the calculated base flow shall be used. For all other developments, a peaking factor of 3.0 times the calculated base flow shall be used.

### 7.4.4 Sanitary Sewer Service Lines

Sanitary sewer services shall consist of a sanitary wye or tee installed on the main sewer, service line piping to the right-of-way or easement line and a cleanout. Customer service line will extend from the service line connection at the sanitary main or manhole to the dwelling or building (customer owned). The customer shall be responsible for maintenance of the entire sanitary sewer service line from the building to the connection to the City's sanitary main or manhole.

In general, it is the intent for each residential dwelling to be served by one service line

## 7.0 UTILITIES (POTABLE WATER AND SANITARY SEWER)

---

of 4-inch or 6-inch diameter. Sanitary sewer services within right-of-way or public easements shall be constructed of either ductile iron pipe, Class 350 or SDR 35 or SDR 26 PVC. Multiple family dwellings and commercial properties requiring a sanitary sewer service of 8-inches in diameter or larger shall connect to the main sewer at a manhole. Prior to backfill, all sanitary sewer services shall be subject to an inspection by the City.

The sanitary sewer service is the customers all the way from the building to the connection with the City's sanitary main. The City will repair/replace the customer's sanitary service if it is damaged under street pavement. Any other problems with the sanitary sewer service is the customer's responsibility. We will investigate a customer's sanitary service if the customer believes that it may be damaged under street pavement. We may end up clearing a stoppage in the customer's sanitary service in the process of investigating the condition of the customer's sanitary service, but we do not simply clear a blockage in a customer's sanitary service for the sake of clearing the blockage.

If the customer believes their sanitary service may be damaged under street pavement and wants us to investigate their sanitary service while a stoppage is present (customer has not cleared stoppage), the customer needs a cleanout near the road and away from the house, so we can use the jetter hose to try to clear the blockage enough in the customer's sanitary service to get the water level to drop and investigate with the CCTV camera. If the customer does not have a cleanout near the road and away from the house, we do not want to use the jetter hose to try to clear the blockage, because using the jetter hose close to a house to clear a blockage has an increased chance of the water backing into the house. We will only check the sanitary main.

If the customer wants us to come stating that they have a cleanout near the road and away from the house or stating that they do not know where their cleanout is located and the customer agrees to the possible service charge, we will come to the customer's address. If we cannot find the customer's cleanout near the road and away from the house, we will not try to clear the blockage if the blockage is close to the house. Then the customer has 5 business days in which to inform us that the blockage is cleared and/or they have installed a cleanout near the road and away from the house, and if the customer does so, we will come back and finish the investigation. If the customer does not notify us within the 5 business days, a service charge will automatically be added to the customer's account.

If the investigation shows that the customer's sanitary service is not damaged under the street pavement, the customer will have a service charge added to their account. If the investigation shows that the customer's sanitary service is damaged under street pavement, the City will repair/replace the customer's sanitary service at no cost to the customer.

#### **7.4.5 Required Sewer Infrastructure Upgrades**

Any upgrades to existing sanitary sewer infrastructure required to provide adequate sanitary sewer service to the proposed development shall be the responsibility of the Project Developer, unless otherwise approved by the City. If sanitary sewer infrastructure must be constructed or upsized to serve areas outside of the proposed project, the City may, but is not required to, participate in the additional costs. Should the City elect to participate in the project, all bidding shall conform to Alabama State Law.

### **7.5 GREASE CONTAINMENT**

Food service establishments or any establishment having the potential to discharge fats, oils, and/or grease into the sanitary sewer system shall obtain a permit to install grease interceptors approved by the Phenix City Utilities Department.

Grease interceptors shall have a minimum capacity of 1,000 gallons and be appropriately sized based on Phenix City Code, Section 82-130. Details on the capacity and construction of all grease traps are subject to review and approval by the City. Additional requirements for grease traps may be found in the Phenix City Code, Section 82-130.

### **7.6 DISPOSAL OF WASTES OTHER THAN DOMESTIC**

#### **7.6.1 Sanitary Sewer Use Ordinance**

Projects that may involve the discharge of wastes to the sanitary sewer system with organic concentrations higher than normal domestic waste (200 mg/l CBOD, 200 mg/l TSS) or compounds that may be detrimental to the normal treatment processes at the wastewater treatment plant, are subject to review by the City's Utility Department to determine the effects of such discharge to the City's wastewater treatment facility. Such discharges shall comply with the City's Sewer Use Ordinance as stated in the Phenix City Code, Chapter 82, Article III, Division 2. Significant Industrial Users as defined by the Sewer Use Ordinance may be required to apply for a Significant Industrial Discharger (SID) permit with the Alabama Department of Environmental Management. Such permits are subject to review and comment by the City's Utilities Department.

#### **7.6.2 Illicit Discharge Elimination Ordinance**

Phenix City operates and maintains a Municipal Separate Storm Sewer System (MS4) and has adopted an ordinance regulating discharges and connection to the storm sewer network within the corporate limits. As such, discharges, other than stormwater are prohibited. Ordinance 2017-01 defines an Illicit Connection *as any man-made conveyance connecting a non-stormwater discharge directly to a municipal separate storm sewer system*. An Illicit Discharge is defined as *any discharge to a municipal separate storm sewer that is not composed entirely of stormwater, except discharges*

## 7.0 UTILITIES (POTABLE WATER AND SANITARY SEWER)

---

*pursuant to an NPDES permit. Further, Stormwater is defined as any surface flow, runoff and drainage consisting entirely of water from any form of natural precipitation and resulting from such precipitation. Stormwater is that portion of the rainfall and resulting surface flow that is in excess of that which can be absorbed through infiltration capacity of the surface of the basin.*

Any establishment, such as commercial car washes, etc. that desires to connect to the City Sanitary Sewage Network with a discharge other than sanitary sewage wastes shall first seek approval from the City. Any improvements to the sanitary sewer infrastructure necessary to accommodate said non-sanitary sewage flow shall be borne by the Developer and/or property owner. In addition, discharges to the City's sanitary sewer infrastructure shall conform to the Sanitary Sewer Use Ordinance as stated in the Phenix City Code, Chapter 82, Article III, Division 2.

DRAFT

**References**

*Phenix City's Water Distribution Specifications* (March 2018)

*Phenix City's Sanitary Sewer Specifications* (March 2018)

*Phenix City's Subdivision Regulations* (Amended and Approved April 12, 2016)

*Code of Ordinances of the City of Phenix City, Alabama* (Amended January 25, 2021)

*Water Resources Engineering, 1st Edition*, Larry W. Mays, John Wiley & Sons, Inc. (2001)

*International Fire Code (IFC)*, International Code Council (2018)

*Rules of State Board of Health, Chapter 420-3-1, Onsite Sewage Treatment and Disposal*, Bureau of Environmental Services, Division of Community Environmental Protection (March 2017)

DRAFT

**APPENDIX 7A**  
**WATER DISTRIBUTION SPECIFICATIONS**

DRAFT

DRAFT





**PHENIX CITY**  
*Alabama*

**UTILITIES DEPARTMENT**

Physical Address: 1119 Broad Street  
Phenix City, AL 36867

Mailing Address: P.O. Box 760  
Phenix City, AL 36868

Ph: 334-448-2880 | Fx: 334-291-4742 | phenixcityal.us

**DR. R. GRIFF GORDY**  
Mayor Pro Tem / At Large

**STEVE BAILEY**  
Councilmember District 1

**EDDIE N. LOWE**  
Mayor

**VICKEY CARTER JOHNSON**  
Councilmember District 2

**ARTHUR L. DAY, JR.**  
Councilmember District 3

WALLACE B. HUNTER, City Manager  
MELONY LEE, City Clerk  
CHARLES D. WOODY II, Utilities Director

### PREFACE

Presented herein are Standard Specifications for the Water Distribution Improvements for the City of Phenix City, Alabama, hereinafter known as the "City". These specifications are to ensure the quality of material, workmanship, and compatibility of products with the existing materials of the City's water system.

Water mains, services and all appurtenances installed upstream of and including the back flow preventers to be tied to water mains being operated and maintained by the City shall conform to these specifications. It shall be the responsibility of the Owner/Developer/Contractor to ensure that all materials and methods of installation of water mains shall strictly conform to these specifications. Any deviations not approved by the City, in writing, shall be grounds for rejection of any part or all water facilities installed. Rejection, at the City's discretion, shall result in the water facilities in question not being allowed to connect to the City's water system and/or not being allowed to receive water service from the City until the Owner/Developer/Contractor proves to the City that all materials and methods of installation of water mains strictly conform to these specifications.

Prior to any laying operation, the Owner/Developer shall submit to the City for approval a set of plans showing size and location of all proposed material and submittal data showing manufacture and model number of all material to be used. The submittal of material and plans in no way relieves the Owner/Developer/Contractor of his responsibility to adhere to these specifications. The Owner/Developer must have written approval from the City of all proposed plans and all proposed material and submittal data prior to the commencement of any work. Upon delivery of material, the Owner/Developer/Contractor shall notify the City and make this material available to its representative for inspection.

The approval of the Utility Construction Drawings indicates review of Construction Drawings for conformance with these Standards and accepted standards of quality. In no way, does the approval make the City or its agents responsible for technical aspects of the design accuracy of the plans and specifications.





**PHENIX CITY**  
*Alabama*

**UTILITIES DEPARTMENT**

Physical Address: 1119 Broad Street  
Phenix City, AL 36867

Mailing Address: P.O. Box 760  
Phenix City, AL 36868

Ph: 334-448-2880

Fx: 334-291-4742

phenixcityal.us

**I. GENERAL AND ADMINISTRATIVE**

**A. Scope**

1. These specifications shall govern the handling, installation, distribution and testing of water distribution systems including pipe, valves, hydrants, and accessories described herein, and as shown on the accompanying plans and details.
2. This work shall consist of laying transmission and distribution lines, fittings, valves, hydrants, and accessories and making service connections.

**B. Work Included**

1. All labor, equipment and material necessary to complete the work stipulated herein. The Contractor shall remove so much of the pavement as may be necessary; excavate the trenches and pits to the required dimensions; excavate the bell holes; construct and maintain all bridges required for traffic control; sheet, brace and support the adjoining ground or structures where necessary; handle all drainage or ground water; guard the site; unload, haul, distribute, lay and test the pipe, fittings, valves, hydrants, and accessories; rearrange the branch connections to main sewers, or rearrange other conduits, ducts or pipes where necessary; replace all damaged drains, sewers, or other structures; backfill and compact the trench pits; restore the roadway surface; remove surplus excavated material; clean the site of the work; perform required tests on the installed water improvements.

**C. Inspection of Work**

1. The Owner/Developer/Contractor shall make available to the City reasonable inspection opportunities. The City also requires all work to be inspected by a qualified representative of the Design Engineer to ensure that the work complies with the City's specifications and the approved plans as submitted to the City.

**D. Regulatory Requirements**

1. In addition to the specifications, all current requirements of the applicable regulatory agencies, including but not limited to the United States Environmental Protection Agency (EPA) and Alabama Department of Environmental Management, (ADEM) shall be met by the contractor.

**E. Traffic Control**

1. Prior to any work requiring traffic control, a traffic control plan prepared in accordance with the latest revision of the MUTCD shall be submitted to the City for approval. It shall be the Contractor's sole responsibility to maintain adequate traffic control, to provide detours around construction activities, and to hold the City harmless from claims arising therefrom. Unless approved by the City in writing, no street shall remain closed to traffic over night. In addition, the Contractor shall cooperate with local residents in gaining access to their homes during working hours and shall assist at all times when vehicles experience trouble due to construction activities.





**PHENIX CITY**  
*Alabama*

**UTILITIES DEPARTMENT**

Physical Address: 1119 Broad Street  
Phenix City, AL 36867

Mailing Address: P.O. Box 760  
Phenix City, AL 36868

Ph: 334-448-2880 | Fx: 334-291-4742 | phenixcityal.us

F. Amendments

1. These specifications may be amended from time to time by the City when the City determines appropriate. It shall be the contractor's responsibility to obtain the latest amendments and/or updates from the City.

G. Layout

1. All systems shall be placed to provide a looped system where practical. Any dead end lines shall be equipped with a fire hydrant at the end of line.
2. Water mains shall be placed on the north and east sides of road rights-of-way where practical.
3. Water mains shall be placed on the opposite side of a road from a storm pipe which is parallel with said road.
4. The water system shall be designed and constructed to have as few crossings of water lines and other utilities (storm, sanitary, etc.) as possible.

H. Easements/Rights-of-Way

1. Water mains, services and appurtenances which are to be owned and/or maintained by the City shall be within an easement dedicated to the City or right-of-way.
2. Easements and/or rights-of-way
  - i. For water mains, easements and/or rights-of-way shall be at least 20 feet wide and be at least 10 feet on each side of the main. If the depth of the main is more than 10 feet, the easement width shall be twice the depth from the ground surface to the bottom of the main rounded up to the nearest 5 foot increment, and the easement shall be centered upon said main.
  - ii. For water services, easements and/or rights-of-way shall be at least 10 feet wide and be at least 5 feet on each side of the service. If the depth of the service is more than 5 feet, the easement width shall be twice the depth from the ground surface to the bottom of the service rounded up to the nearest 5 foot increment, and the easement shall be centered upon said service.
  - iii. Where public water mains pipes are installed within easements crossing private property, the City shall have the right to enter upon the easement for purposes of inspecting, repairing, or replacing the water pipes and appurtenances. Where paved private streets, driveways, parking lots, etc. have been installed over public water pipes, the City shall not be responsible for the repair or replacement of pavement, curbing, landscaping, etc. which must be removed to facilitate inspection, repairs and/or replacement. The City shall only be responsible for backfill of excavated areas to approximately the original grade. Replacement of privately owned pavement, curbing, walkways, etc. shall be the responsibility of the property owner.

I. Abbreviations

1. AASHTO: American Association of State Highway and Transportation Officials







**PHENIX CITY**  
*Alabama*

**UTILITIES DEPARTMENT**

Physical Address: 1119 Broad Street  
Phenix City, AL 36867

Mailing Address: P.O. Box 760  
Phenix City, AL 36868

Ph: 334-448-2880

Fx: 334-291-4742

phenixcityal.us

2. ADEM: Alabama Department of Environmental Management
3. ANSI: American National Standards Institute
4. ASTM: American Society for Testing and Materials
5. AWWA: American Water Works Association
6. EPA: United States Environmental Protection Agency
7. NFPA: National Fire Protection Association
8. NSF: National Sanitation Foundation

**II. CONTRACTOR/DEVELOPER RESPONSIBILITY** – The Contractor and Developer are responsible for ensuring that the construction meets these specifications. Any part of the construction which does not meet these specifications shall be repaired or replaced to meet these specifications at no cost to the City of Phenix City.

**III. CONTRACTOR RESPONSIBILITY**

**A. Installation and Safety**

1. The Contractor shall be responsible for installation of the water mains and appurtenances in accordance with the approved construction drawings, notifying the Project Engineer of any discrepancies noted in actual field conditions.
2. Any changes or alterations to the approved design that are requested by the Contractor shall be reviewed and approved by the Project Engineer and the City of Phenix City prior to work beginning in the area of the requested change.
3. Any water installation that is not in accordance with the approved construction drawings shall be removed and installed properly according the approved construction drawings prior to acceptance by the City of Phenix City.
4. The contractor shall obtain written approval from the Phenix City Utilities Department prior to making any connection to the Phenix City Utilities Department's water system. All connections to said system must be coordinated and performed in the presence of a City inspector or representative of the Phenix City Utilities Department. The written approval shall be presented to the inspector or representative of the Phenix City Utilities Department at the time the connection is made.
5. Barricades, flashers, signs, and other protective devices shall be used when needed to adequately provide for public safety. Such devices shall be supplied, installed and maintained by the Contractor. The Contractor will be solely responsible for safety.

**B. Certifications**

1. All pipe, fittings, valves and other materials shall be new and unused when delivered to the work site and shall be suitable for installation and operation under the conditions for which they are to be used. All pipes and all fitting shall be suitably marked at their places of manufacturer to show their class or strength. Any pipe or



**PHENIX CITY**  
*Alabama*

**UTILITIES DEPARTMENT**

Physical Address: 1119 Broad Street  
Phenix City, AL 36867

Mailing Address: P.O. Box 760  
Phenix City, AL 36868

Ph: 334-448-2880 | Fx: 334-291-4742 | phenixcityal.us

other materials, which have been broken, cracked or otherwise damaged before or after delivery to the work site, or which have failed to meet the required tests, shall be removed from the work site and shall not be used in the work.

2. Detailed construction drawings for pipe in large meter vaults, pressure producing stations, etc., shall be submitted to the Phenix City Utilities Department for review before such materials are fabricated and delivered to the work site.
3. The manufacturer of ductile iron pipe, fittings, and gate and butterfly valves shall furnish the Phenix City Utilities Department, when requested, certification that these materials comply with the appropriate ANSI/AWWA Standard and that compliance has been verified by specified tests and inspection.
4. Other types of pipe, fittings, and valves shall be inspected and accepted under these specifications by an approved commercial testing laboratory prior to delivery to the work site. Each piece of pipe, fitting, etc., shall be stamped with the laboratory's mark of acceptance and inspection reports shall be furnished to the Phenix City Utilities Department when requested.

#### C. Testing

1. The Contractor is responsible for testing all aspects of the water system as outlined in this document in conjunction with the Phenix City Utilities Department. All testing requirements shall be arranged and paid by the contractor. The testing laboratory shall be approved by the City. Results from all required testing shall be provided to the City for review.

#### D. Site Restoration

1. The Contractor shall clean up and legally dispose of all excess material, trash, wood forms, and other debris. Previously grassed areas that are excavated shall be reestablished with sod of the same type and species as the surrounding grass.
2. In unimproved areas or areas which do not appear to have been sodded, the disturbed ground shall be seeded with approved Alabama Department of Transportation Mix for permanent vegetation, unless specified otherwise.
3. After completing each section of the water line, the Contractor shall remove all debris, construction materials, and equipment from the site of the work, grade and smooth over the surface on both sides of the line, and leave the entire right-of-way or easement in a clean, neat, and serviceable condition.
4. All permanent easements shall be graded and smoothed to allow sufficient access and use for mowing equipment and maintenance vehicles prior to acceptance by the Phenix City Utilities Department. The permanent easement shall be completely cleared of all trees, brush, boulders, and debris. All rocks shall be buried, crushed, or removed from the easement where, in the opinion of the Phenix City Utilities Department, they present a hazard for access and use of the easement. Typically, no rock shall remain on the ground surface that is larger than a No. 1 stone



**PHENIX CITY**  
*Alabama*

**UTILITIES DEPARTMENT**

Physical Address: 1119 Broad Street  
Phenix City, AL 36867

Mailing Address: P.O. Box 760  
Phenix City, AL 36868

Ph: 334-448-2880 | Fx: 334-291-4742 | phenixcityal.us

classification.

5. All creek and ditch crossings shall be located completely within the permanent easement and shall also be made accessible for mowing and maintenance equipment as deemed appropriate by the Phenix City Utilities Department.
6. When the water main is not installed along a road, the contractor shall install an access drive along the path of the new water main and within the water and/or utility easement which is easily navigable with a standard truck and which will support a full sized, steel track mounted excavator without disturbing the ground or damaging the water main.

**IV. EXCAVATION AND BACKFILLING** - The Contractor shall excavate all substances encountered to the depth shown on the construction drawings. Excavated materials not required and/or not suitable for fill or backfill shall be disposed of by the Contractor in a manner acceptable to the Project Engineer or Project Manager.

**A. General Excavation Requirements**

**1. Utility Location**

- i. Contractor shall call Alabama 811 service (811 or 1-800-292-8525) and the Phenix City Utilities Dispatch (334-448-2902) not less than three (3) working days before performing work.
  - ii. Request underground utilities to be located and marked within and surrounding construction areas.
  - iii. If after two (2) working days, all utility companies have not located their buried lines, call Alabama 811 and/or Phenix City Utilities Dispatch and inform them which utilities have not marked their lines.
2. Excess excavation below the required level shall be backfilled with an approved fill, and thoroughly tamped.
  3. Unsuitable soil shall be removed and replaced with approved crushed stone or other approved material, and shall be thoroughly tamped.
  4. The ground surface adjacent to all excavations shall be graded to prevent water from running into the excavation. The Contractor shall remove any water accumulated in the excavation and keep the trench dewatered.
  5. The trench shall be excavated so that the pipe will be laid in the center of the trench in its designed location. The trench width shall be a minimum of six inches (6") wider than the pipe bell diameter, and a maximum of twenty-four inches (24") wider than the pipe bell diameter.
  6. The Contractor shall provide, install and maintain all bracing, sheeting, and shoring necessary to perform and protect all excavations as required for safety and to conform to all governing laws.

**B. Rock Excavation**







**PHENIX CITY**  
*Alabama*

**UTILITIES DEPARTMENT**

Physical Address: 1119 Broad Street  
Phenix City, AL 36867

Mailing Address: P.O. Box 760  
Phenix City, AL 36868

Ph: 334-448-2880

Fx: 334-291-4742

phenixcityal.us

1. Rock shall be defined as any material, which occurs in its original position in ledges or bedded deposits of such hardness or texture that cannot be reasonably excavated, loosened, broken, or removed without the use of drilling and blasting methods utilizing a Caterpillar 320, Kobelco 200, Komatsu 220, or comparable trench excavation equipment having a SAE rated net power of at least one hundred and forty-eight horsepower (148 hp) and bucket force of at least thirty-one thousand pounds (31,000 lbs). Concrete and masonry structures that require drilling and blasting for removal and boulders having volumes greater than eight (8) cubic feet shall also be considered rock.
2. In general, removal of rock will be considered as unclassified excavation and no specific payment will be made therefore except when a bid item is provided in the Bid Schedule for rock excavation. When payment is to be made on a unit price basis for removing rock, the rock shall be completely stripped of all overburden over the entire area, if for a structure, and over a length of at least fifty feet (50') if for a pipeline. The Project Engineer will then make the necessary measurements and take elevations on the rock to determine the volume of rock to be removed.
3. In no case will pavements, manholes, and similar structures be classified as rock nor will specific payment be made for drilling and blasting materials that can be removed by other methods.
4. Excavations shall be carried six inches (6") below bottom of pipe and bedding material shall be 825A or 825B as per ALDOT standard specifications.
5. In trenches for pipelines, rock shall be removed for the overall width of the trench as specified and to a depth of six inches (6") below the bottom of the pipe for pipes smaller than twenty four inches (24") in diameter. For pipes greater than twenty four inches (24") in diameter, rock shall be removed to a depth of twelve inches (12") below the bottom of the pipe. If concrete cradles are to be constructed, rock shall be removed to allow the cradle to be constructed to the depth shown on the construction drawings.
6. All storage places for explosives and inflammable materials shall be clearly marked. The method of storing and handling such materials shall conform to all Federal, State, and local laws.
7. Drilling and blasting methods used in rock excavation shall be optional with the Contractor but shall be conducted with due regard to the safety of persons and property in the vicinity of the work and in strict conformity with all laws, ordinances or regulations governing blasting and the use of explosives.
8. Rock excavation near existing structures of all types shall be conducted with the utmost care, and every precaution shall be taken to prevent damage to such structures. Damage or injury of any nature to persons or property, caused directly or indirectly by blasting operations, shall be promptly repaired, replaced or



**PHENIX CITY**  
*Alabama*

**UTILITIES DEPARTMENT**

Physical Address: 1119 Broad Street  
Phenix City, AL 36867

Mailing Address: P.O. Box 760  
Phenix City, AL 36868

Ph: 334-448-2880

Fx: 334-291-4742

phenixcityal.us

compensated for by the Contractor at the Contractor's sole expense and to the entire satisfaction of the persons injured or the owners of the property damaged.

### C. Backfilling

1. After pipes have been visually checked for defects, backfilling shall be done with approved material free from large clods or stones, sticks, logs, stumps, or other unsuitable materials.
2. Backfill material shall be placed evenly and carefully around and over pipe in six inch (6") maximum layers and mechanically compacted. Each layer shall be carefully placed until one foot (1') of cover exists over the pipe. The remainder of backfill materials shall be placed in twelve inch (12") layers and mechanically compacted, unless approved otherwise by the Phenix City Utilities Department or Geotechnical Engineer.
3. Fill with voids is not allowed.
4. At vaults and other structures, all forms, trash, and debris shall be removed and cleared away. Backfill material shall be placed symmetrically on all sides in twelve inch (12") maximum layers. Each layer shall be at the optimum moisture content to achieve the best compaction and compacted with mechanical tampers.
5. Trenches cut across or along pavement/roadways shall be backfilled and compacted as required by the Phenix City Subdivision Regulations. Temporary asphalt patches shall be placed in accordance with the current City of Phenix City Standard Specifications and Details.
6. For pipe in fill sections or projecting into fill sections, where pipe is not structurally supported, unsuitable material shall be removed. A foundation shall be constructed using approved foundation material per the Geotechnical Engineer or Project Engineer and a pipe bed shall be constructed using approved bedding material. Subsequently, embedment material shall be placed symmetrically on each side of pipe to a point one foot (1') above the pipe in six inch (6") maximum layers and compacted.
7. The Contractor shall be responsible for repairing all settled backfilled areas.
8. Testing compaction of backfill under roadways shall be done in accordance with the testing requirements for street construction of the Phenix City Engineering Department. The developer and/or contractor shall submit the compaction test results to the Phenix City Engineering Department as soon as the results are available.

## V. MATERIALS

### A. Pipe

1. General
  - i. Pipe four inches (4") in diameter and larger shall be ductile iron pipe with "push-







- on" joints for installation underground and flanged joints for exposed pipe.
  - ii. Fittings for underground ductile iron pipe shall have mechanical joints and may be made of gray (cast) iron or ductile iron, as noted and approved.
  - iii. Flanged fittings for twelve inch (12") and smaller pipe may be either gray or ductile iron. Flanged fittings larger than twelve inches (12") shall be ductile iron unless shown otherwise on the approved construction drawings.
  - iv. Any exceptions to these specifications will be noted on the construction drawings and/or in the Special Conditions if applicable and must be approved by the Phenix City Utilities Department prior to installation.
  - v. Any changes in the approved design shall receive written approval by the Project Engineer and the City of Phenix City before they are implemented.
  - vi. All material shall comply with ADEM Admin. Code r. 335-7-8.
2. Ductile Iron Pipe
- i. Ductile iron pipe shall comply with ANSI A21.51 and AWWA C151.
  - ii. Pipe to be installed underground shall be Pressure Class 350 for size three inches (3") to twenty-four inches (24") except where a higher class is shown on the construction drawings, in the Special Conditions, or required due to the depth of the cover shown on the construction drawings based on Type 2 laying condition.
  - iii. Minimum working pressure shall be two hundred and fifty pounds per square inch (250 psi) plus one hundred pounds per square inch (100 psi) water hammer.
3. Flanged Pipe
- i. Flanged pipe shall comply with ANSI B16.1 Class 250 and AWWA C110, C115, and C151.
  - ii. Bolts, nuts, and studs for flanged joints shall be hexagonal type of low carbon steel conforming to ASTM A307 Grade B and ANSI B18.2.
4. Fittings
- i. Ductile iron fittings, with either mechanical joints or flanges, shall comply with ANSI A21.10 and AWWA C110 or ANSI A21.53 and AWWA C153 (compact).
  - ii. Ductile iron mechanical joint fittings in sizes four inches (4") to twenty-four inches (24") shall have a pressure rating of 350 psi.
5. Joints/Joint Materials
- i. Ductile iron pipe with "Push-on" and mechanical joints and fittings shall conform to ANSI A21.11 and AWWA C111.
  - ii. Ductile iron pipe with Flanged joints and fittings shall conform to ANSI A21.10, A21.15, B16.1, and AWWA C110.
  - iii. Joint materials for "push-on" and mechanical joints shall be furnished by the manufacturer of the pipe and shall comply with ANSI A21.11.
6. Gaskets
- i. Standard gaskets for "push-on" joint ductile iron pipe shall be manufactured of



- Styrene Butadiene Rubber (SBR) conforming to the material requirements of ANSI A21.11, and AWWA C111, and shall be ANSI/NSF Standard 61 certified for contact with potable water.
- ii. Locking or restrained joint gaskets for “push-on” joint ductile iron pipe shall be standard SBR gaskets with high strength stainless steel wedging elements equally spaced around the gasket for restraining action. Locking gasket fittings shall comply with ANSI A21.11 and A21.53, and AWWA C111 and C153, and shall be ANSI/NSF Standard 61 certified for contact with potable water.
  - iii. Full-face or ring gaskets for flanged ductile iron pipe shall be manufactured of Styrene Butadiene Rubber (SBR) conforming to the material requirements of ANSI A21.11 and AWWA C111, and shall be ANSI/NSF Standard 61 certified for contact with potable water.
7. Externally Restrained Joints
- i. Externally restrained joints for pipe sizes four inches (4") to twenty inches (20") shall be mechanical joints with ductile iron “Mega-Lug” or approved equal with a minimum working pressure of three hundred and fifty pounds per square inch (350 psi) and concrete thrust blocks.
  - ii. Joints shall be externally restrained in areas where thrust restraint is required or where fittings are installed, unless otherwise approved by the Phenix City Utilities Department.
  - iii. Length of restraint shall be determined by the Project Engineer.
  - iv. Mechanical joint restraint shall be constructed of ASTM A536 ductile iron and shall conform to ANSI A21.10, A21.11 and 21.53, and AWWA C110, C111, and C153.
  - v. Mechanical joint restraint shall be equipped with torque limiting twist off nuts.
  - vi. The devices shall have a working pressure-rating equal to that of the pipe on which it is used. Ratings are for water pressure and must include a minimum safety factor of 2:1 in all sizes.
8. Flexible Couplings
- i. Flexible Couplings for ductile iron pipe shall be mechanical joint sleeves or conductive Dresser Couplings.
  - ii. Couplings shall be properly sized for the pipes on which they are used.
9. Linings and Coatings
- i. All ductile iron pipe and fittings shall have a standard cement lining complying with ANSI A21.4.
  - ii. Pipe and fittings to be installed underground shall be asphaltic coated in accordance with ANSI A21.4.
  - iii. Above ground exposed piping shall be thoroughly cleaned of all dirt, mill scale, or rust and prime coated with Tnemec 77 or equivalent coating approved by the



**PHENIX CITY**  
*Alabama*

**UTILITIES DEPARTMENT**

Physical Address: 1119 Broad Street  
Phenix City, AL 36867

Mailing Address: P.O. Box 760  
Phenix City, AL 36868

Ph: 334-448-2880

Fx: 334-291-4742

phenixcityal.us

Phenix City Utilities Department.

### 10. Copper Tubing

- i. Copper tubing shall be seamless type K soft copper water tube in accordance with ASTM standards and be furnished in coils, be rated for underground service, and shall comply with Federal Specification WW-T-799.
- ii. Copper tubing shall be used for all one inch (1"), one and one half inch (1 ½") and two inch (2") service lines.
- iii. Fittings and joints shall be threaded, flare or compression connections. Press fittings and push-on fittings are not allowed.

### 11. Drain Pipe

- i. Drain pipe shall have a minimum three inch (3") diameter and shall be of the type shown on the construction drawings.

### 12. Exposed Outside Pipe

- i. Exposed outside piping shall be insulated to prevent freezing where specifically shown on the construction drawings. Insulating materials shall be one inch (1") thick Armaflex 22 sheet flexible foam plastic with closed cellular structure as manufactured by Armstrong Industry Products or approved equal and galvanized steel bands.
- ii. After installation, the insulation shall be coated with Armstrong Armaflex Finish (vinyl lacquer coating), or approved equal.

### 13. Strainers

- i. Except for ultrasonic meters and meters with no moving parts, strainers shall be installed before water meters one and one-half inches (1½") and larger and shall be Master Meter or approved equal. Bodies shall be epoxy coated steel suitable for a minimum of one hundred and fifty pounds per square inch (150 psi) working pressure. Screens shall be stainless steel.

## B. Valves

### 1. Gate Valves - Two Inch (2") Diameter and Larger

- i. Gate valves two inches (2") in diameter or larger shall be iron-body, bronze mounted, inside-screw, hand-operated resilient seat, with non-rising stems, and shall be equipped with rubber O-Ring Seals at the top of the stems unless otherwise shown on the construction drawings and approved by the Phenix City Utilities Department.
- ii. Valves shall conform to the requirements of AWWA Specification C500, except as such specifications are herein modified.
- iii. Gate valves shall be designed for minimum working pressure of two hundred pounds per square inch (200 psi).
- iv. Gate valves shall be as manufactured by Mueller Company, M & H, American





PHENIX CITY  
Alabama

UTILITIES DEPARTMENT

Physical Address: 1119 Broad Street  
Phenix City, AL 36867

Mailing Address: P.O. Box 760  
Phenix City, AL 36868

Ph: 334-448-2880

Fx: 334-291-4742

phenixcityal.us

- Darling or approved equal.
  - v. Two inch (2") diameter valves shall have threaded connections unless shown otherwise on the construction drawings.
  - vi. Valves three inches (3") in diameter and larger, shall have mechanical joints for use underground and shall have flanged joints if they are to be installed in structures. Flanges for all pressure ratings shall be faced and drilled to comply with ANSI Specifications A21.15.
  - vii. Gate valves shall be hand operated and designed to turn left or counterclockwise to open.
  - viii. Valves installed underground shall have square operating units.
  - ix. Exposed valves shall be flanged, have hand wheels or manual floor stands with an arrow for opening cast into said hand wheel as shown on the construction drawings.
  - x. Suitable extension stems or operating keys shall be furnished to properly operate all valves installed with valve boxes, and all necessary guides and supports for valve stems shall be furnished and installed where required.
  - xi. All gate valves installed underground shall be equipped with standard cast iron valve boxes unless otherwise approved by the Phenix City Utilities Department.
  - xii. Where valves are shown to be of different diameter than the connecting piping the two reducers required shall be included as fittings.
  - xiii. The Contractor shall submit to the Phenix City Utilities Department and Project Engineer complete catalog information showing principal dimensions, weights, and specifications and operating data for all valves.
  - xiv. All internal parts shall be accessible without removing the valve body from the pipe.
2. Gate Valves - Less than Two Inch (2") Diameter
- i. Gate Valves smaller than two inches (2") in diameter shall be Class 150, or Class 200, as shown on the construction drawings. Where not specifically shown on the construction drawings, gate valves shall be Class 150.
  - ii. Valves shall be of all bronze construction with rising stems.
  - iii. Class 150 valves shall be Crane Co., No. 431 UB; Class 200, Crane Co., No. 424, or approved equal.
  - iv. Small gate valves shall be installed with all pipe connections and fittings necessary to serve the purpose intended.
3. Butterfly Valves - Sixteen Inch (16") Diameter and Larger
- i. Butterfly valves shall be tight closing rubber-seated valves that comply with all requirements of AWWA Specification C504, latest revisions.
  - ii. Valves shall be suitable for throttling service, frequent operation, or operation after long periods of inactivity.



**PHENIX CITY**  
*Alabama*

**UTILITIES DEPARTMENT**

Physical Address: 1119 Broad Street  
Phenix City, AL 36867

Mailing Address: P.O. Box 760  
Phenix City, AL 36868

Ph: 334-448-2880

Fx: 334-291-4742

phenixcityal.us

- iii. Except when shown otherwise, valves shall be Class 150 B.
  - iv. When requested, the manufacturer shall furnish the Phenix City Utilities Department an "Affidavit of Compliance" with AWWA Specification C504, latest revision.
  - v. Butterfly valves shall be as manufactured by Mueller, Henry Pratt Co., Dresser Industries, Val-Matic, Clow Corp., or approved equal.
  - vi. Valve bodies shall be cast iron or ductile iron complying with ASTM A126, Class B. Valves to be installed underground shall have mechanical joint ends; exposed valves shall have flanged ends conforming to ANSI B16.1, Class 125. Where the rubber seat is mounted on the vane, the body shall be fitted with a 360-degree stainless steel seat offset from the shaft, mechanically retained.
  - vii. Valve discs shall be constructed either of alloy cast iron ASTM A436, Type 1 (Ni-Resist) or of ductile iron ASTM A536 Grade 65-45-12. Where the rubber seat is mounted in the body, the mating edge of the disc shall be 18-8 stainless steel, Type 304 or Type 316.
  - viii. Valve shafts shall be turned, ground, and polished. Shafts shall be constructed of 18-8, Type 304 stainless steel. Shafts may be one-piece units that extend full size through the valve disc or the stub type for use with solid ductile iron discs.
  - ix. Valve seats, either natural rubber or synthetic rubber, shall be installed on either the valve disk or valve body. Seats installed on the valve disk shall be mechanically retained. Seats in valves in twenty inches (20") and smaller sizes may be vulcanized to the body or mechanically retained. Seats vulcanized to the body shall withstand a seventy-five pound (75 lb.) pull under test procedure ASTM D429, Method B.
  - x. Valve bearings shall be the sleeve type, corrosion resistant, and self-lubricating. Bearing load shall not exceed one-fifth (1/5) that of the compressive strength of the bearing or shaft material and shall not exceed two thousand five hundred pounds per square inch (2,500 psi).
  - xi. Valve interior surfaces, except seating surfaces, shall be evenly coated with a suitable primer to inhibit rust or a black asphalt varnish.
  - xii. Valve operators shall be suitable for underground service and shall be fully gasketed, grease packed, watertight, and shall be provided with extension stem and operating nut, cast iron valve box, and tee wrench for opening and closing valves. Valves shall close in a clockwise rotation of the stem.
4. Small Ball Valves (Less than Two Inch Diameter)
- i. Ball valves smaller than two inches (2") in diameter shall be lever operated valves with bronze bodies and trim and with end connections suitable for installation as shown on the construction drawings.
  - ii. Valves shall be Clincher model as manufactured by Mueller, Jamesbury Corp., or



Accesso Model as manufactured by Crane Co., or approved equal.

5. Valve Boxes

- i. All valves installed underground shall be provided with a cast iron valve box to house and protect the valve stem.
- ii. Valve boxes shall be of the adjustable screw type with a shaft diameter of five and one-fourth inches (5 ¼").
- iii. The base shall be round or oval.
- iv. The box shall be provided with an extension section so that when installed the cover will be flush with the finished grade when in paved areas and slightly above ground surface (approximately ½") when in unpaved areas.
- v. All valve boxes installed in unpaved areas shall have a concrete collar installed according to the standard details. Where a precast collar is installed, the annular space between the valve box and the concrete collar shall be filled with grout.
- vi. Ductile iron, cast iron & PVC pipe shall not be used as valve box extension unless approved by the Phenix City Utilities Department. PVC used as a valve box extension shall be Schedule 80 or SRD 26.
- vii. Valve box lids shall have "WATER" cast into the top.

6. Automatic Air Release Valves

- i. Air release valves shall be air/vacuum valve type and shall be furnished and installed in the sizes shown on the approved construction drawings.
- ii. Air release valves shall have a minimum working pressure of one hundred and seventy five pounds per square inch (175 psi), shall be tested at three hundred pounds per square inch (300 psi).
- iii. Air release valves shall be designed to automatically release air during filling and admit air during draining operations.
- iv. Air release valves shall be equipped with a polypropylene float and a rolling seal mechanism.
- v. Air release valves shall be as manufactured by ARI or approved equal.
- vi. Air release valves shall be installed in a standard meter box in accordance with the standard details.
- vii. An isolation valve shall be provided at the connection point.

C. Pressure Regulators

1. Water pressure regulators shall be of the diaphragm type furnished with stainless steel strainers (except when a filter is required) and shall be of the sizes shown on the approved construction drawings.
2. Each regulator shall be suitable for a maximum inlet pressure of two hundred and fifty pounds per square inch (250 psi) and the outlet pressures shown on the approved construction drawings.





**PHENIX CITY**  
*Alabama*

**UTILITIES DEPARTMENT**

Physical Address: 1119 Broad Street  
Phenix City, AL 36867

Mailing Address: P.O. Box 760  
Phenix City, AL 36868

Ph: 334-448-2880

Fx: 334-291-4742

phenixcityal.us

3. Outlet pressure settings shall be adjustable.
4. Pressure regulators shall be manufactured by Watts, Cla-Val, Bermad, or approved equal.

#### D. Pressure Gauges

1. Pressure gauges for piping or pumps shall be liquid filled, of the Bourdon Tube type having phosphor bronze or stainless steel tubes, aluminum cases, and steel rings.
2. Cases and rings shall be finished in black enamel.
3. Dials shall be three and one-half inches (3-1/2") in diameter.
4. Gauges shall be manufactured by Marsh Instrument Co., or Marshalltown Manufacturing Company, or approved equal.
5. Each gauge shall be installed with one-fourth of an inch (1/4") brass pipe, complete with gauge cock and Ray Pressure Snubber.

#### E. Fire Hydrants

##### 1. General

- i. All fire hydrants shall conform to the requirements of AWWA Specification C502, except as such specification is modified herein.
- ii. Fire hydrants shall be Mueller, M & H, or American Darling, traffic type hydrants with breakaway bolts, flanges or lugs. The fire hydrant shall also include a breakaway stem coupling. Aluminum couplings are not acceptable. The fire hydrant head section shall have either 4, 6, or 8 bolts at the connection of the standpipe.
- iii. Fire hydrants shall be furnished with two (2) hose connections each two and one-half inches (2-1/2") in diameter and one (1) four and one-half inch (4-1/2") diameter pumper connection, unless approved otherwise. Fire hydrant caps shall have inside gaskets. The connections or nozzles shall be lug or screw type and shall be brass. Leaded nozzles will not be accepted.
- iv. Operating and nozzle cap nuts shall be pentagon shape, 1-1/4-inches from point to opposite flat at base of nut and 1-3/16-inches (30 mm) from point to opposite flat at top of nut with a tolerance of 1/64-inch for each dimension from flat to opposite point.
- v. The valve openings shall be five and one-quarter inches (5-1/4") and the standpipe shall be six inches (6") inside diameter, unless approved otherwise. Fire hydrant shall be furnished with two or more bronze brushed drain valves. Drain valves shall close within six (6) turns, at the start of opening the hydrant.
- vi. Hydrants shall be designed for mechanical joint connections unless otherwise approved.
- vii. Unless otherwise directed by the Phenix City Fire Department, the nozzles and



**PHENIX CITY**  
*Alabama*

**UTILITIES DEPARTMENT**

Physical Address: 1119 Broad Street  
Phenix City, AL 36867

Mailing Address: P.O. Box 760  
Phenix City, AL 36868

Ph: 334-448-2880

Fx: 334-291-4742

phenixcityal.us

caps threads shall conform to NFPA No. 194 for National Standard Fire Hose Coupling Screw Threads.

- viii. Hydrants shall be equipped with safety flanges.
- ix. Hydrants shall be designed to open by turning the operating nut left, or counter-clockwise. An arrow and the word "OPEN" shall be cast in relief on the top of the hydrant to designate the direction of opening. The main valve seat ring and seat ring bushings shall be bronze. Removal of main valve assembly, including seat ring, shall be by a tool that engages the stem either at the breakaway stem coupling or the upper stem section.
- x. At the factory, the outside of the top section of the hydrant shall be thoroughly cleaned and given a coat of primer per AWWA C502 and a second coat of yellow high gloss machinery enamel.

2. Installation

- i. Install fire hydrants; provide support blocking and drainage gravel; do not block drain hole.
- ii. Set hydrants plumb with pumper nozzle facing roadway.
- iii. The buried length of each hydrant shall be suitable for operating under the conditions shown on the approved construction drawings and shall be the vertical distance from the bottom of the connecting pipe to the ground line of the hydrant when installed.
- iv. The center of hydrant nozzles shall be between sixteen inches (16") and twenty inches (20") above the finished surface.
- v. Hydrants shall have no more than one (1) riser installed, and said riser shall be no more than twelve inches (12") in height unless otherwise approved.
- vi. The Contractor shall repaint hydrants after installation with primer per AWWA C502 and a second coat of yellow high gloss machinery enamel as needed if the paint is damaged or the appearance marred.
- vii. There shall be no obstructions within 3 feet of any hydrant. Obstructions include but are not limited to the following:
  - a. Vegetation (shrubs, trees, vines, bushes)
  - b. Structures (power poles, light poles, mail boxes, flag poles, utility structures and appurtenances)
  - c. Rock (natural outcrop, decorative)
- viii. After hydrostatic testing, flush hydrants and check for proper drainage.

F. Services

1. New Service Connections

- i. Service connections and lines shall be installed as shown on the approved construction drawings and/or as specified in the Special Conditions.







PHENIX CITY  
Alabama

UTILITIES DEPARTMENT

Physical Address: 1119 Broad Street  
Phenix City, AL 36867

Mailing Address: P.O. Box 760  
Phenix City, AL 36868

Ph: 334-448-2880 | Fx: 334-291-4742 | phenixcityal.us

- ii. New services installed shall be a minimum of one inch (1") diameter for  $\frac{3}{4}$ " and 1" meters.
  - iii. New services shall have a minimum horizontal clearance of five (5) feet from any paved driveway and/or sidewalk.
  - iv. New water mains and new water services shall not be installed in the same trench as sanitary sewer mains and sanitary sewer services.
  - v. Each new service shall have its own connection to the main – e.g., a property wanting a 6" fire protection line, a 2" potable water line and a 1" irrigation line would require 6", 2" and 1" water taps on the City's main.
  - vi. Tapping sleeves shall be ductile iron or stainless steel with a full circumferential gasket and a flanged or mechanical joint outlet.
2. Existing Service Connections
- i. Existing services that are to be abandoned or terminated as part of the project shall be disconnected at the distribution system main line and removed from the ground at the full expense of the Contractor unless otherwise approved by the Phenix City Utilities Department and Engineering Department.
  - ii. In no case are existing services to be crimped, clamped, or inadequately sealed for permanent abandonment, but shall be completely severed from the distribution system and appropriately sealed off utilizing a corporation stop, valve, sleeve, restrained plug, or other prescribed method approved by the Phenix City Utilities Department to prevent future leakage.
  - iii. Any existing services that have been omitted or not accurately shown on the construction drawings are notwithstanding from this requirement should they be discovered on the project site. It is the responsibility of the Contractor to locate all existing services prior to beginning construction.
  - iv. Driveways placed near existing services shall have a minimum horizontal clearance of five (5) feet from any existing service.

G. Meters

1. Meters shall be of the size and type as shown on the approved construction drawings and as specified in the Special Conditions.
2. Meters shall be manufactured by Master Meter and shall be equipped with 3G DS radio read systems.
3. Developments requiring meters that are larger than two (2) inches or more than six individual three-fourths of an inch ( $\frac{3}{4}$ ") meters shall install the meters in a precast or cast in place vault per the standard details.
4. No more than twelve individual meters shall be installed in a single vault.



**PHENIX CITY**  
*Alabama*

**UTILITIES DEPARTMENT**

Physical Address: 1119 Broad Street  
Phenix City, AL 36867

Mailing Address: P.O. Box 760  
Phenix City, AL 36868

Ph: 334-448-2880

Fx: 334-291-4742

phenixcityal.us

## H. Vaults

### 1. General

- i. Vaults shall be of the size and type as shown on the approved construction drawings and specified in the Special Conditions.
- ii. The appurtenances in and around a vault shall be arranged according to the appropriate standard detail for the purpose in which the service and vault is intended.

### 2. Concrete

- i. Vaults may be pre-cast or cast-in-place concrete.
- ii. Concrete shall be four thousand pounds per square inch (4000 psi) concrete mix with steel wire and/or bar reinforcement as required by the vault design engineer.
- iii. All openings in the concrete for piping and appurtenances shall be appropriately grouted and sealed to ensure water tightness in the vault.
- iv. All vaults shall have steel reinforced polypropylene steps mounted in the concrete.

### 3. Hatch

- i. The hatch shall be aluminum construction rated for a minimum of three hundred pounds per square foot (300 lb/sf) loading.
- ii. All hardware shall be Type 316 stainless steel.
- iii. The hatch shall be equipped with an automatic hold-open door device, water tight slamlock, and removable key wrench.
- iv. The frame and cover shall be cast into the concrete and shall be flush with the top of the concrete vault.
- v. The hatch shall span the entire length and width of the vault to provide maximum opening access to the interior of the vault.
- vi. The hatch shall be manufactured by U.S. Foundry, Bilco, or approved equal.

### 4. Dimensions

- i. Vaults for pipes larger than two inches (2") in diameter shall be of adequate size to allow a minimum of twelve inches (12") spacing around all appurtenances, and between paralleling appurtenances for maintenance and repair.
- ii. Vaults for pipes two inches (2") in diameter or smaller shall be of adequate size to allow a minimum of 4 inches (4") spacing around all appurtenances, and between paralleling appurtenances for maintenance and repair.
- iii. The specific vault dimensions shall be in accordance with the applicable standard details.
- iv. The top of the vault shall be no more than six inches (6") above finish grade.
- v. Vaults shall be placed at an adequate distance from any other utility lines or



**PHENIX CITY**  
*Alabama*

**UTILITIES DEPARTMENT**

Physical Address: 1119 Broad Street  
Phenix City, AL 36867

Mailing Address: P.O. Box 760  
Phenix City, AL 36868

Ph: 334-448-2880

Fx: 334-291-4742

phenixcityal.us

- structures to allow safe excavation for any needed repairs.
- vi. Vaults shall be no more than six feet (6') deep and shall have no additional pre-cast riser sections added without prior approval by the Phenix City Utilities Department.
5. Drain
- i. All vaults are required to acquire positive drainage from the vault through a floor drain to grade or to a storm sewer collection system unless otherwise approved by the Phenix City Utilities Department.
  - ii. The drain shall be a minimum three inches (3") in diameter and cast into the floor.
  - iii. The floor of the vault shall be constructed to drain to the floor drain opening.
  - iv. No sidewall drains are permitted.
  - v. The vault shall be placed on No. 57 stone or larger at a minimum depth of six inches (6").
  - vi. If it is demonstrated that positive drainage cannot be acquired, approval may be given on a case by case basis to construct a "false bottom" of No. 57 stone or larger. The volume of the stone under the vault shall then be greater than or equal to the volume of the vault, and shall be at a minimum twelve inches (12") deep and extend a minimum of twenty four inches (24") from all sides of the vault.
6. Piping and Fittings
- i. All piping and fittings inside the vault shall be flanged ductile iron.
  - ii. All external piping around the vault shall be mechanical joint with Mega-Lug retainer glands, or approved equal.
  - iii. All piping and assemblies shall be centered in the vault.
  - iv. Pipe supports shall be aluminum or stainless steel.
- I. Backflow Prevention Assemblies
1. General
    - i. Backflow protection shall be required on all service connections to the Phenix City water system. Service connections include but are not limited to potable water services, irrigation water services, and fire protection water services. Fire protection water services include a hydrant or hydrants on private property.
    - ii. Backflow prevention assemblies shall be required on any fire hydrants which will be located on private property and connected to the City of Phenix City's water system.
    - iii. Backflow protection devices shall be manufactured by Ames, Watts, or approved equal.
    - iv. The size of the backflow prevention device shall be equal to or greater than the





- size of the purchased meter (e.g., a one (1) inch meter shall have a one (1) inch or larger backflow device).
2. Dual Check Valve (DCV)
    - i. Shall be installed in a standard meter box directly downstream of all potable water only meters that are one (1) inch in diameter and smaller according to the standard details.
    - ii. When the degree of hazard presented by the Customer requires a higher level of system protection, the Customer will be required to install an approved backflow prevention assembly (DCBA or RPBA).
  3. Double Check Backflow Assemblies (DCBA)
    - i. Shall have a Master Meter 3G DS meter.
    - ii. Shall be installed below grade in a vault in accordance with the standard details.
    - iii. The DCBA device shall meet AWWA C510-97 (latest revision), be approved by the Foundation for Cross-Connection Control and Hydraulic Research of the University of Southern California, and comply with all local plumbing codes.
  4. Reduced Pressure Backflow Assemblies (RPBA)
    - i. Shall be installed in an above ground enclosure system according to the standard details such as a Hydrocowl, Hot Box, Lok Box, or approved equal.
    - ii. The RPBA device shall meet AWWA C511-97 (latest revision), be approved by the Foundation for Cross-Connection Control and Hydraulic Research of the University of Southern California, and comply with all local plumbing codes.
    - iii. If a meter is not installed on the service line upstream of the RPBA, said RPBA shall have a detector check meter which shall be a Master Meter 3G DS meter.
  5. Degree of Hazard
    - i. Hazardous – During the course of business, the facility may use, process or store significant amounts of contaminants that would be considered Toxic to Human Health if they were introduced into the public water supply, (e.g. toxic chemicals, toxic dyes, acids, alkalies, toxic detergents, bacterial cultures, blood & tissue waste, solvents, toxic insecticides & herbicides, antifreezes, sewage, etc.). The following partial listing gives examples of the types of facilities which would require an acceptable RPBA to be installed in the service connection to the public water distribution system:

Type of Facility	Potential Hazard
Sewage & industrial wastewater treatment plants & plumbing stations, sewer flushers, etc.	Sewage industrial wastewater, contaminated water, toxic chemicals, etc.
Paper manufacturing or processing, dye plants, petroleum processing, printing plants, chemical manufacturing or processing, industrial fluid systems, steam	Toxic chemicals, water conditioning Compounds (Examples: Toxic dyes, acids, alkalies, solvents, quaternary ammonia compounds, mercury, chromium, etc.)



**PHENIX CITY**  
*Alabama*

**UTILITIES DEPARTMENT**

Physical Address: 1119 Broad Street  
Phenix City, AL 36867

Mailing Address: P.O. Box 760  
Phenix City, AL 36868

Ph: 334-448-2880 | Fx: 334-291-4742 | phenixcityal.us

generation, rubber processing, tanneries	
Canneries, breweries, food processing, milk processing, ice manufacturing, meat packers, poultry processing, rendering companies, etc.	Process wastewater, steam, detergents, acids, caustics, refrigeration lines
Hospitals, clinics, laboratories, veterinary hospitals, mortuaries, embalmers, etc.	Bacterial cultures, laboratory solutions, blood & tissue waste, toxic materials, etc.
Shipyards, marinas, etc.	Contaminated water, sewage, etc
Metal-plating, photo-processing, laundries, commercial car washes, commercial refrigeration systems, dry cleaning establishments, etc.	Toxic chemicals, concentrated cleaning agents, solvents, etc. (Examples: Cyanides, fluorides, copper, chromium, caustic & acid solutions, etc.)
Commercial greenhouses, spraying & irrigation systems using weedicides, herbicides, exterminators	Toxic chemicals (Examples: Ammonium salts, phosphates, 2,4 D sodium arsenite, lindane, malathion, etc.)
Boiler systems, cooling towers or internal firefighting systems using conditioners, inhibitors, corrosion control chemicals, etc. (Typically: apartment buildings, cooling towers, warehouses)	Toxic chemicals (Examples: Hydrazine, sodium compounds, antifreeze solutions, etc.)

- ii. Aesthetically Objectionable – During the course of business, the facility does not use contaminants that are considered Toxic, but may use, process or store significant amounts of contaminants that if introduced into the public water supply may affect the taste, temperature, odor, color, and/or the aesthetic features of the public water supply (e.g. stagnant water, non-toxic soaps and/or cleaning agents, food grade dyes, non-chemically treated boiler/cooling water, etc.). The following partial listing gives examples of the types of facilities which would require an acceptable DCBA to be installed in the service connection to the public water distribution system:

Type of Facility	Potential Hazard
Customer fire protection loops, fire storage tanks; with no chemical additives	Stagnant water, objectionable tastes, odors
High temperature potable water	Objectionable temperatures
Utilization of food grade dyes	Objectionable color
Complex plumbing systems in commercial Buildings (Typically: barber shops, beauty salons, churches, apartment buildings, gas stations, supermarkets, nursing homes, construction sites, carnivals)	Plumbing errors, obsolete plumbing equipment, poor plumbing inspection/correction programs

- iii. Non-Hazardous – The facility does not use, process or store significant amounts of contaminants that would be considered toxic, or of aesthetic concern by the



**PHENIX CITY**  
*Alabama*

**UTILITIES DEPARTMENT**

Physical Address: 1119 Broad Street  
Phenix City, AL 36867

Mailing Address: P.O. Box 760  
Phenix City, AL 36868

Ph: 334-448-2880

Fx: 334-291-4742

phenixcityal.us

above Hazardous/Aesthetically Objectionable definitions (e.g. office buildings, retail stores, commercial establishments utilizing public water for rest room and drinking fountains, private homes, etc.). Facilities which are classified as non-hazardous will require a non-testable dual check valve at a minimum.

6. Fire Protection Systems

- i. Backflow prevention assemblies on non-metered flow such as isolated fire protection systems shall be equipped with detector check meters in the assembly.
- ii. On metered fire protection systems that require sprinkler protection, backflow prevention shall be installed upstream of the Fire Department Connection for each individually isolated sprinkler system.

7. Testing and Certification

- i. Following installation, all DCBAs and RPBA's are required to be tested by a certified backflow prevention assembly tester within ten (10) days and submitted to the Phenix City Utilities Department.
- ii. For all backflow prevention assemblies larger than 1" in diameter, the owner is required to have annual tests performed on said backflow prevention assemblies by a certified backflow prevention assembly tester, and the owner shall submit the results of said tests to the City of Phenix City Utilities Department within ten (10) days of receiving said test results.
- iii. Required maintenance of the backflow prevention device and appurtenances and annual testing of the device shall be the Owner's responsibility.

**VI. CONSTRUCTION METHODS**

A. General

1. Upon delivery, the contractor shall inspect all pipe and accessories for damage and defect.
2. All pipe, fittings, valves, hydrants, and other accessories shall, unless otherwise directed, be unloaded at the point of delivery, hauled to and distributed at the site of the project by the Contractor; they shall at all times be handled with care to avoid damage. In loading and unloading, they shall be lifted by hoists in such a manner as to avoid shock. Pipe should never be rolled off the carrier vehicle or dropped onto the ground or on old tires or other cushions. Under no circumstances shall they be dropped. Precautions should be taken to prevent the pipe from rolling or shifting during unloading. Do not slide or drag pipe or other water system materials.
3. Pipe and accessories shall be handled in such a manner as will insure delivery to its final position in an undamaged condition. Pipe coating and lining shall be carefully protected. Damaged coating shall be repaired in a manner satisfactory to the City.
4. The inside of each section shall be thoroughly cleaned just before it is placed in final







**PHENIX CITY**  
*Alabama*

**UTILITIES DEPARTMENT**

Physical Address: 1119 Broad Street  
Phenix City, AL 36867

Mailing Address: P.O. Box 760  
Phenix City, AL 36868

Ph: 334-448-2880 | Fx: 334-291-4742 | phenixcityal.us

- position, and shall be kept clean and free of water during laying operations.
5. No pipe shall be laid in water or when the trench or other conditions are unsuitable for such work.
  6. Water shall be kept out of the pipe trench until the pipe has been laid and the joints are completed.
  7. All pipe shall be inspected just before it is placed in final position and rung with a light hammer to detect defects.
  8. Damaged and/or defective material shall not be installed in the water system and shall not be accepted by the City of Phenix City for use in the water system. Any pipe or accessories found to be defective, damaged or otherwise unsuitable for its purpose, either before or after its installation, shall be removed by the Contractor and replaced with acceptable pipe or accessory at Contractor's sole expense.
  9. The spigot end of each piece shall be examined for burrs that could damage a gasket. Anything which could damage a gasket shall be removed from the pipe before assembling pipe.
  10. The cutting of pipe for closure pieces or for other purposes shall be done in a neat and workmanlike manner, without damage to the pipe; by the use of a wheel cutter or other approved type of mechanical cutter.
  11. No pipe shall be laid in trenches where the depth of cover will be less than thirty inches (30") unless otherwise approved by the Phenix City Utilities Department.
  12. Pipes ten (10) inches and larger shall have minimum of thirty six (36) inches cover unless otherwise approved by the Phenix City Utilities Department.
  13. Water mains shall not exceed depths of cover greater than eight feet (8') unless otherwise approved by the Phenix City Utilities Department.
  14. Temporary support, adequate protection and maintenance of all underground and surface utility structures, drains, sewers, and other obstructions encountered in the progress of the work shall be furnished by the Contractor at his own expense.
  15. If an obstruction is encountered which the water line cannot be routed to avoid, the obstruction shall be permanently supported, removed, relocated, or reconstructed by the Contractor after he has obtained the approval of and through cooperation with the Owner of the obstruction.
  16. All pipe shall be laid and maintained to the required lines and grades; with fittings and valves at the required locations; and with joints centered and spigots home; and with all valve stems plumb. When the pipe is in its final position, the invert of the pipe shall be at the elevation and grade shown on the approved construction drawings.
  17. If a water line must cross a storm sewer or sanitary sewer pipe, the water line shall be installed above the storm sewer or sanitary sewer pipe unless it is not possible and otherwise approved by the Phenix City Utilities Department.



**PHENIX CITY**  
*Alabama*

**UTILITIES DEPARTMENT**

Physical Address: 1119 Broad Street  
Phenix City, AL 36867

Mailing Address: P.O. Box 760  
Phenix City, AL 36868

Ph: 334-448-2880

Fx: 334-291-4742

phenixcityal.us

18. No deviation shall be made from the required line or grade except with the consent of the Project Engineer and the Phenix City Utilities Department.

B. Laying Pipe

1. Each piece of pipe shall be placed in the trench with the full length of the barrel resting upon the prepared bedding and with the bell over a bell hole excavated at the proper place to accommodate the bell and permit preparation of the joint.
2. Bell holes shall be of sufficient size to allow ample room for properly making the pipe joints. The bottom of the trench between bell holes shall be carefully graded so that the pipe barrel will rest on a solid foundation for its entire length.
3. Where angular deflections are necessary due to vertical or horizontal curves, the maximum allowable deflection for "push-on" joints shall be as per the pipe manufacturer's recommendation. Where greater total deflection is required than can be obtained using factory standard lengths, the Contractor shall cut the pipe and install shorter lengths or install appropriate degree bends.
4. Except where necessary to make connections with other lines, pipes shall be laid with the bell facing the direction of lying. For lines on an appreciable grade the joints shall be faced upgrade unless otherwise approved by the Phenix City Utilities Department.
5. After each piece of pipe has been lowered into the trench and before jointing operations are started, all lumps, blisters and excess coating materials shall be removed from the surfaces to be joined and the outside of the spigot end and the inside of the joint shall be wire brushed, wiped clean and dry, and all oil and grease removed. The cleaning operation shall be repeated, if necessary, just prior to making the joint. File spigot ends to remove burs.
6. The fittings at all bends in underground pressure lines shall be securely anchored to prevent the fittings from blowing off when under pressure.
7. Where pipe ends are dead-ended to permit future connections, they shall be valved, plugged, or capped and appropriately restrained. Three (3) joints of pipe are required between the valve and the plug/cap. If the distance available is not sufficient to allow for three (3) joints of pipe, the valve, plug, and previous joints of pipe must be restrained using external restraint mechanisms approved by the Phenix City Utilities Department or a concrete "deadman" anchor in accordance with the standard details.
8. Connections between new and old lines and between different kinds and types of pipe shall be made with standard or special fittings to suit the actual conditions and shall be made in a neat and workmanlike manner acceptable to the Phenix City Utilities Department and the Project Engineer.
9. Mechanical and "push-on" joints for ductile iron pipe and fittings shall be installed in strict accordance with the recommendations of the manufacturer.





**PHENIX CITY**  
*Alabama*

**UTILITIES DEPARTMENT**

Physical Address: 1119 Broad Street  
Phenix City, AL 36867

Mailing Address: P.O. Box 760  
Phenix City, AL 36868

Ph: 334-448-2880 | Fx: 334-291-4742 | phenixcityal.us

10. Bell holes shall be of sufficient size to allow ample room for properly making the pipe joints. The bottom of the trench between bell holes shall be carefully graded so that the pipe barrel will rest on a solid foundation for its entire length.
  11. All pipe in place shall be carefully protected from damage until backfilling operations have been completed.
  12. Water shall not be allowed to run or stand in the trench while pipe laying is in progress or before the trench has been backfilled. The Contractor shall not open at any time more trench than his available pumping facilities are able to dewater. Do not lay pipe in wet or frozen trench.
  13. If the Contractor chooses to leave the trenches open after the pipe is in place and the joints completed and inspected by the Inspector, backfilling shall begin as soon as possible after approval by the Inspector. If the Contractor chooses to backfill the trenches before the pipe is inspected by the Inspector, the Contractor may have to excavate portions of the pipe to allow the Inspector to visually inspect portions of said pipe.
  14. Any leaks or defects discovered at any time after the completion of the work shall be repaired immediately.
  15. New water mains and new water services shall not be installed in the same trench as sanitary sewer mains and sanitary sewer services.
- C. Bore Installation
1. Where road borings are required, they shall typically be a traditional jack-and-bore construction method using a steel casing unless otherwise approved by the Phenix City Utilities Department for directional drilling methods to be used.
  2. All bores for water mains and services shall be aligned and delivered precisely to the location shown on the construction drawings to minimize additional fittings required at the main connection. Tolerance shall be as follows:
    - i. Line Tolerance: 2 inches, maximum.
    - ii. Grade Tolerance: 2 inches, maximum
  3. The carrier pipe shall be pressure class 350 ductile iron, and the pipe joints shall be restrained using external restraint mechanisms or locking gasket restraints.
  4. The carrier pipe shall be encased in welded steel pipe, having a minimum wall thickness of one-fourth of an inch (1/4") in accordance with Table A.
  5. Casing spacers shall be used to convey the carrier pipe through the encasement and keep the carrier pipe centered in the casing. The casing spacers shall be Cascade CCS models or approved equal.
  6. The casing shall be sealed at each end with rubber boot and double band stainless steel straps to prevent any water or other materials from entering the encasement. The casing seals shall be Cascade CCES model or approved equal.



7. Where possible, the steel casing shall extend at least five feet (5') beyond the edge of the roadway or planned roadway widening, but shall in no case continue within five feet (5') of a water main connection, fitting, or valve.
8. Where water service connections are being made, the existing water main shall be excavated as part of the receiving pit, prior to setting up the bore, to verify the necessary depth and grade shown on the construction drawings.
9. All other utilities shall be located and potholed, where necessary, prior to performing the bore.
10. Table A outlines the minimum casing sizes based on the carrier pipe size:

Table A

Carrier Pipe		Steel Casing		
Nominal Pipe Diameter	Standard Pipe Bell O.D.*	Casing Spacer Band Width	Minimum Casing Thickness	Minimum Casing Inside Diameter**
4	6.40	8	0.25	14
6	8.60	8	0.25	16
8	11.16	8	0.25	18
10	13.25	8	0.25	20
12	15.22	8	0.25	22
14	17.73	12	0.25	24
16	19.86	12	0.3125	26
18	22.16	12	0.3125	30
20	24.28	12	0.3125	32
24	28.50	12	0.3125	36
30	34.95	12	0.5	42
36	41.37	12	0.5	48

All sizes are indicated in inches.

\*Pipe bell outside diameter based on Pressure Class 350 ductile iron pipe.

\*\*Casing inside diameters are based on being a minimum of 6 inches greater than the outer diameter of the joint bell, to the nearest even inch.

D. Flanged Ductile Iron Pipe

1. Flanged pipe shall be installed in accordance with the recommendations of the manufacturer.



**PHENIX CITY**  
*Alabama*

**UTILITIES DEPARTMENT**

Physical Address: 1119 Broad Street  
Phenix City, AL 36867

Mailing Address: P.O. Box 760  
Phenix City, AL 36868

Ph: 334-448-2880 | Fx: 334-291-4742 | phenixcityal.us

2. The faces of the flanges on two adjacent sections shall be carefully centered and the sections adjusted to proper line and grade before the flange bolts are tightened.
  3. Gaskets shall be placed in position without damage. Any gasket damaged in the process shall be discarded. They shall be attached to the flange by rubber gum before the joint is made up in a manner that will prevent displacement.
  4. After the pipes have been properly centered and adjusted to true line and grade they shall be firmly bolted together, care being taken to tighten all nuts uniformly around the flange with a torque wrench to 75-95 ft/lbs or as otherwise recommended by the manufacturer.
  5. Suitable flanged wall fittings or thimbles shall be used where pipes pass through walls of structures.
- E. Setting Valves, Valve Boxes, Fittings, and Blow-offs
1. Gate and butterfly valves and pipe fittings shall be set and connected to the pipe in the manner heretofore specified for cleaning, laying and joining pipe.
  2. Cast-Iron valve boxes shall be installed on all underground valves and shall be firmly supported, centered, and plumbed over the operating nut, with box cover flush with finished pavement or slightly above ground surface (approximately 1/2") in non-paved areas, unless otherwise approved by the Phenix City Engineering and Utilities Departments.
  3. Valve boxes shall be installed on a firm base at the proper elevation and then carefully backfilled and tamped.
  4. After final backfill has been installed and approved by the Phenix City Utilities Department and Project Engineer, a concrete collar as shown on the standard details shall be installed around each valve box. The annular space between precast collars and valve box shall be filled with grout, and the top of the valve box shall be flush with the top of the concrete collar.
  5. Valve boxes set in paved areas shall be erected with the top flush with the surface of the pavement in an approved traffic rated enclosure. In its final position, the box shall not touch the valve stem at any point.
  6. Ductile iron pipe, cast iron pipe and PVC pipe shall not be used as a valve box extension unless approved by the Phenix City Utilities Department.
  7. Drainage branches or blow-offs shall not be connected to any sewer or submerged in any stream or be installed in any other manner that will permit back-siphonage into the distribution system.
- F. Setting Fire Hydrants
1. All fire hydrants shall be set plumb and shall conform to the established grade.
  2. The center of nozzles shall be between sixteen inches (16") and twenty inches (20") above ground surface.
  3. Wherever hydrants are set in impervious soil, a drainage pit two feet (2') in diameter





**PHENIX CITY**  
*Alabama*

**UTILITIES DEPARTMENT**

Physical Address: 1119 Broad Street  
Phenix City, AL 36867

Mailing Address: P.O. Box 760  
Phenix City, AL 36868

Ph: 334-448-2880 | Fx: 334-291-4742 | phenixcityal.us

and two feet (2') deep shall be excavated below each hydrant and filled compactly with coarse gravel or crushed stone under and around the bowl of the hydrant and to a level six inches (6") above the waste opening. Hydrant drainage pits shall not be connected to a sewer.

4. The bowl of each hydrant shall be well braced against unexcavated earth at the end of the trench with concrete backing.
5. Set hydrants plumb with pumper nozzle facing roadway.

G. Thrust Restraint – Thrust restraint will be required for all water lines with inside diameter of four inches (4") or larger where unbalanced forces exist. This shall include all ends of main locations where plugs or caps are installed and all changes in size or direction where fittings such as reducers, tees, horizontal bends, vertical bends, etc. are installed. Generally, areas needing thrust restraint shall be minimized by utilizing pipe deflection in lieu of additional bends and fittings. Where required, thrust restraint shall adhere to the practices outlined in the DIPRA Manual for Thrust Restraint design for ductile iron pipe and the City of Phenix City standard details. Non-standard thrust blocking will require special detailing provided by a licensed engineer and approved by the Phenix City Utilities Department.

1. Restrained Joint Devices
  - i. The minimum allowed thrust restraint allowed is externally restrained joint devices such as "Mega-Lug" or approved equal. For bends, tees and fire hydrant boots, externally restrained joint devices shall be used with concrete blocking.
  - ii. All thrust restraint shall be installed as shown on the construction drawings.
  - iii. The exact linear footage of restraint shall be measured from the flange of the fitting which is being restrained.
2. Concrete Blocking
  - i. Reaction or thrust backing of 2,000psi concrete (minimum compressive strength at 28 days) shall be applied on pressure pipe lines up to twelve inches (12") in diameter.
  - ii. All tees, plugs, caps and bends shall be wrapped in plastic prior to pouring concrete.
  - iii. Plastic shall be four (4) mil minimum high-density polyethylene or eight (8) mil minimum low density polyethylene, per AWWA C105.
  - iv. The thrust bearing sides of all concrete blocking shall be poured against firm undisturbed soil and the non-thrust bearing sides shall be formed at an angle to the undisturbed soil.
  - v. Restraint using metal harnesses, tie rods, pipe clamps, etc. anchored by concrete blocking shall only be used where approved and shown on the construction drawings. Steel rods and clamps shall be of an approved design and stainless



**PHENIX CITY**  
*Alabama*

**UTILITIES DEPARTMENT**

Physical Address: 1119 Broad Street  
Phenix City, AL 36867

Mailing Address: P.O. Box 760  
Phenix City, AL 36868

Ph: 334-448-2880

Fx: 334-291-4742

phenixcityal.us

steel.

- vi. Concrete blocking shall be installed so that the pipe and fitting joints will be accessible for repair.

H. Connection to Existing Mains

1. Except when shown otherwise on the construction drawings, connections to existing water mains shall be made by cutting and removing a portion of the existing pipe and inserting a standard mechanical joint tee (or cross) and valves.
2. At locations shown on the construction drawings, connections to existing mains shall be made by installing tapping sleeves and valves.
3. Connections must be two inches (2") smaller than existing main when utilizing a stainless steel tapping sleeve.
4. Ductile iron tapping sleeves may be approved on a case by case basis for same size taps.
5. All connections to live mains must be done with a Phenix City Inspector and/or a Phenix City Utilities Department representative present.
6. No taps smaller than one inch (1") shall be permitted unless approved by the Phenix City Utilities Department for an existing water service.
7. The tapping sleeve and valve shall have the same manufacturer.

I. Separation from Sanitary Sewer

1. Except where a sanitary sewer line and water line cross each other, all water lines shall be placed with a minimum horizontal clearance of ten (10) feet, measured edge to edge, from any existing or proposed sanitary sewer main and/or structure, unless otherwise approved by the Phenix City Utilities Department. Except where a sanitary sewer line and water line cross each other, a water line shall be placed no closer than five (5) feet horizontally from a sanitary sewer line or structure (ADEM Admin. Code r. 335-7-7-.03a) and shall not be placed through a sanitary structure.
2. Where ten (10) feet of horizontal clearance cannot be achieved:
  - i. Sewer line shall be ductile iron.
  - ii. The water line shall be installed above the sanitary pipe to achieve a minimum vertical clearance of eighteen (18) inches between the water and sanitary pipes.
3. Where it is necessary for a water line to cross a sanitary sewer line:
  - i. The water and sanitary sewer lines shall cross as close to 90° as possible and no less than 75°.
  - ii. If possible, place a continuous casing around one of the mains to allow a ten (10) foot separation between each end of the cased and uncased main. At a minimum, place a continuous casing around one of the mains to allow a minimum five (5) foot separation between each end of the cased and uncased main (ADEM Admin. Code r. 335-7-7-.03a).
  - iii. Install the water line above the sanitary pipe if possible. If the water line is not



above the sanitary line, the sanitary line shall be ductile iron.

- iv. Install the water line to achieve a minimum vertical clearance of eighteen (18) inches between the water and sanitary pipes (ADEM Admin. Code r. 335-7-7-.03a). If eighteen (18) inches of vertical clearance between the water and sanitary pipes is not possible, the sanitary main, if in the casing, shall be ductile iron to a point five (5) feet past the ends of said casing or, if not in the casing, shall be ductile iron and have a full joint (minimum 18 feet) of pipe centered on the crossing with the water main in the casing.

- 4. Unless adequately cased to protect against cross contamination, do not install any water main such that it comes in contact with any part of a sewer manhole, septic tank field lines, or soil saturated with organic solvents or gasoline (ADEM Admin. Code r. 335-7-7-.03a).

J. Separation from Storm Sewer

- 1. Water mains shall be separated from storm sewer mains and structures by a minimum of thirty-six (36) inches horizontally and twelve (12) inches vertically unless otherwise approved by the Phenix City Utilities Department. In no case shall a water main be allowed inside a storm sewer structure.

K. Separation from other utilities, structures, et cetera

- 1. Water mains shall be separated from other pipes and structures by a minimum of five (5) feet horizontally and twelve (12) inches vertically unless otherwise approved by the Phenix City Utilities Department.

VII. TESTING

A. Visual Tests (required)

- 1. All materials shall be subject to being visually inspected by the Inspector at the site for conformance to the required specifications. When reasonable doubt exists that said material meets the specifications, the City of Phenix City may require samples, and/or tests by an independent laboratory or other suitable form of verification that the material meets the required specifications.
- 2. The Inspector will visually inspect the water and construction site periodically during construction and at the completion of construction. The Contractor shall immediately repair all noted leaks, defects, and deficiencies upon such inspection.

B. Hydrostatic Pressure Test (required)

- 1. All newly installed pressure pipe (mains and services), or any valved section thereof, shall be subjected to a hydrostatic test at a pressure one and one-half (1-1/2) times the working pressure at the point of testing, but not less than two hundred pounds per square inch (200 psi) for two hours (2 hrs.) and shall not show a loss of more than five pounds per square inch (5 psi) over such time. If the system fails the tests, necessary repairs shall be made and lines shall be retested.





PHENIX CITY  
*Alabama*

UTILITIES DEPARTMENT

Physical Address: 1119 Broad Street  
Phenix City, AL 36867

Mailing Address: P.O. Box 760  
Phenix City, AL 36868

Ph: 334-448-2880

Fx: 334-291-4742

phenixcityal.us

2. Air should be expelled from the line before testing.
  3. It shall be the contractor's responsibility to pass the pressure test. Any extra valves, taps, plugs, or bracing required to perform testing procedures will be at the contractor's sole expense.
  4. All air release valves shall be isolated or removed prior to flushing and pressure testing the line.
  5. Each valved section of pipe shall be slowly filled with clean water and the specified pressure shall be applied by means of a pump connected to the pipe in a satisfactory manner. The pump, pipe connection, gauges, meters and other apparatus required for the tests shall be furnished and installed by the Contractor.
  6. The test shall be conducted at the point directed by the Inspector, Project Engineer, or Owner. The contractor at his own expense shall install the test point.
  7. The test shall be recorded on a Bristol Babcock pressure gauge chart or a water pressure data logger approved by the City. The chart with the record pressure or water pressure data log shall be submitted to the City.
  8. All services which are connected to the water main being tested shall be on to test for pressure with the main.
  9. Before applying the specified test pressure, all air shall be expelled from the pipe (includes services). To accomplish this, taps shall be made, if necessary, at points of highest elevation, and afterward tightly plugged or converted to permanent manual air release valves at the discretion of the Phenix City Utilities Department.
  10. All exposed pipes, fittings, valves, and joints shall be carefully examined. All leakage in joints shall be completely stopped.
  11. Any cracked or defective pipes, fittings, or valves discovered in consequence of this pressure test, shall be removed and replaced by the Contractor with sound material in the manner herein before provided and the test shall be repeated until satisfactory to the Phenix City Utilities Department.
  12. Should any test of combined section of pipe disclose leakage, the Contractor shall, at his own expense, locate and repair the defective joints until the leakage has been completely stopped.
- C. 24 Hour Hydrostatic Pressure Test (optional in lieu of 2 hour test)
1. The 24 hour test shall have the same requirements as the 2 hour test except the following:
    - i. All newly installed pressure pipe, or any valved section thereof, shall be subjected to a hydrostatic test at a pressure one and one-half (1-1/2) times the working pressure at the point of testing, but not less than one hundred and fifty pounds per square inch (150 psi).
    - ii. The pipe shall hold the test pressure for a minimum of twenty-four hours (24 hrs) with no leakage on pipe.



**PHENIX CITY**  
*Alabama*

**UTILITIES DEPARTMENT**

Physical Address: 1119 Broad Street  
Phenix City, AL 36867

Mailing Address: P.O. Box 760  
Phenix City, AL 36868

Ph: 334-448-2880

Fx: 334-291-4742

phenixcityal.us

D. Disinfection (required)

1. Completed potable water mains and services shall be disinfected with chlorine after the mains and services have been flushed and passed the pressure test but prior to being placed in service.
2. Each valved section of main and services shall be thoroughly flushed at a rate of at least five feet per second (5 fps), and all dirt and foreign matter shall be removed. Flushing shall be done after pressure testing.
3. The Contractor shall pump a solution of sodium hypochlorite or calcium hypochlorite (HTH) into the mains and services, with the Inspector present, in a manner that will result in a concentration of chlorine of at least fifty parts per million (50 ppm) throughout the pipe.
4. All valves shall be operated and services opened while the pipe contains the chlorine solution, before the twenty four (24) hour contact time clock is started.
5. The solution shall remain in the pipe for at least twenty four (24) hours to kill all non-spore forming bacteria, and after twenty four (24) hours the concentration shall be at least twenty five parts per million (25 ppm) in all parts of the pipe.
6. After disinfection is complete, the chlorinated water shall be flushed from the main and services at its extremities until the replacement water shall, by test, be proven to be safe for human use.
7. After chlorination, the Inspector shall submit water samples from water mains to the Phenix City Water Filtration Plant Laboratory for bacteriological examination.
8. Should the initial treatment prove ineffective, the procedure shall be repeated until confirmed tests show that water sampled from the pipe conforms to the Alabama Department of Environmental Management bacterial requirements.

VIII. MAINTENANCE – The Contractor shall maintain all street and road surfaces, trench backfill and all completed sections of pipelines in good condition until the warranty period ends and the City of Phenix City accepts the infrastructure for maintenance. The Phenix City Utilities Department may use completed sections of the water mains when needed even prior to the acceptance of said water mains for maintenance by the City of Phenix City. However, such use shall not relieve the Contractor of his responsibility for maintaining or replacing defective work.

IX. Private and Public Service Piping

- A. Potable water service extends to end users through service piping. For the purposes of these Specifications, the service piping is described in two segments, each with unique responsibility assignments.
- B. The first segment extends from the City-owned distribution point or pipe to the water meter and is referred to herein as the public service piping. The City of Phenix City is responsible for maintaining the public service piping. The public service piping includes all





**PHENIX CITY**  
*Alabama*

**UTILITIES DEPARTMENT**

Physical Address: 1119 Broad Street  
Phenix City, AL 36867

Mailing Address: P.O. Box 760  
Phenix City, AL 36868

Ph: 334-448-2880

Fx: 334-291-4742

phenixcityal.us

infrastructure associated with the service installed from the City's water main to the water meter. This may include valves, valve boxes, water service meters, and related items unless otherwise specified by the City.

- C. The portion of the service piping that extends from the water meter towards the property of the end user is referred to herein as the private service piping. The end user is responsible for maintaining the private service piping.

DRAFT



**PHENIX CITY**  
*Alabama*

**UTILITIES DEPARTMENT**

Physical Address: 1119 Broad Street  
Phenix City, AL 36867

Mailing Address: P.O. Box 760  
Phenix City, AL 36868

Ph: 334-448-2880

Fx: 334-291-4742

phenixcityal.us

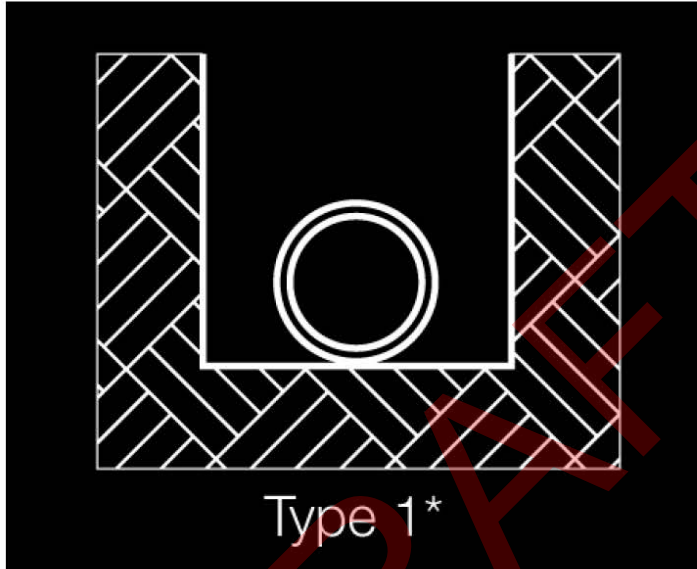

Flat-bottom trench. Loose backfill. (Not recommended for 14" and larger pipe.)



**PHENIX CITY**  
*Alabama*

**UTILITIES DEPARTMENT**

Physical Address: 1119 Broad Street  
Phenix City, AL 36867

Mailing Address: P.O. Box 760  
Phenix City, AL 36868

Ph: 334-448-2880

Fx: 334-291-4742

phenixcityal.us

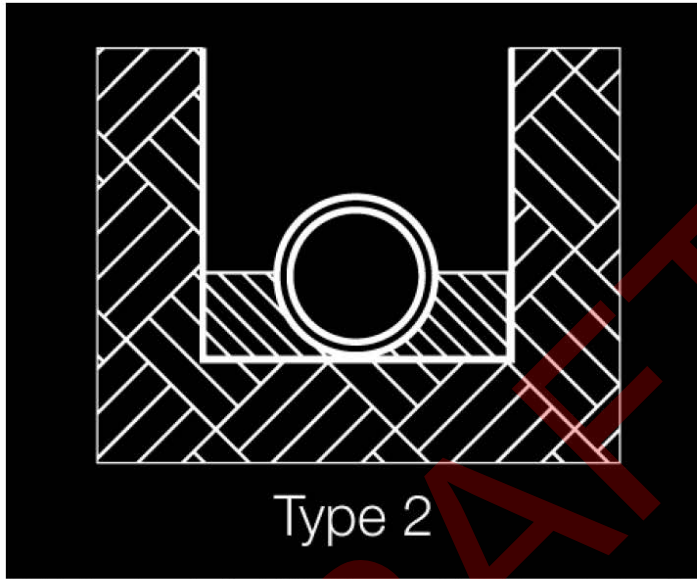

Flat-bottom trench. Backfill lightly consolidated to centerline of pipe.

DR



**PHENIX CITY**  
*Alabama*

**UTILITIES DEPARTMENT**

Physical Address: 1119 Broad Street  
Phenix City, AL 36867

Mailing Address: P.O. Box 760  
Phenix City, AL 36868

Ph: 334-448-2880

Fx: 334-291-4742

phenixcityal.us

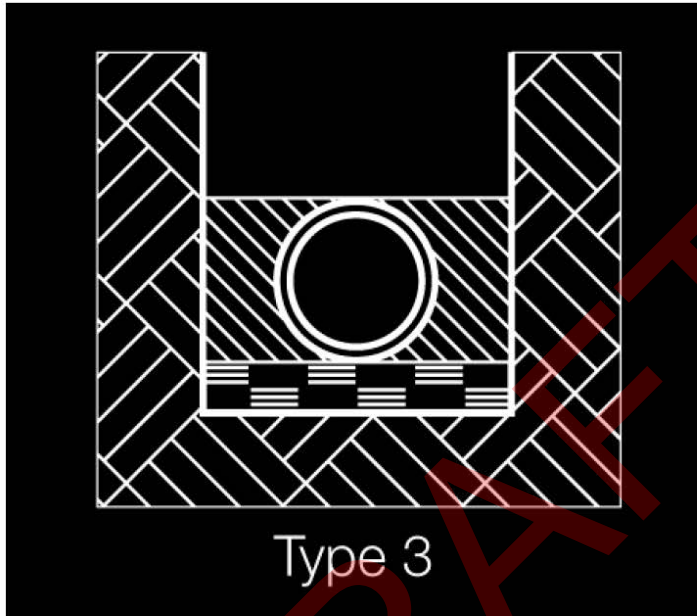

Pipe bedded in 4" minimum loose soil. Backfill lightly consolidated to top of pipe.



**PHENIX CITY**  
*Alabama*

**UTILITIES DEPARTMENT**

Physical Address: 1119 Broad Street  
Phenix City, AL 36867

Mailing Address: P.O. Box 760  
Phenix City, AL 36868

Ph: 334-448-2880

Fx: 334-291-4742

phenixcityal.us

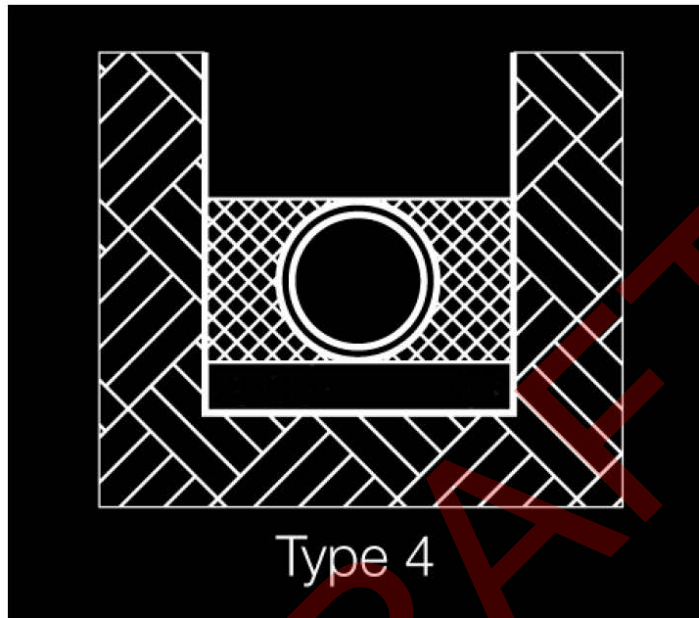

Pipe bedded in sand, gravel or crushed stone to depth of 1/8 pipe diameter, 4" minimum. Backfill compacted to top of pipe. (Approximately 80% Standard Proctor, AASHTO T-99.)



PHENIX CITY  
*Alabama*

UTILITIES DEPARTMENT

Physical Address: 1119 Broad Street  
Phenix City, AL 36867

Mailing Address: P.O. Box 760  
Phenix City, AL 36868

Ph: 334-448-2880

Fx: 334-291-4742

phenixcityal.us

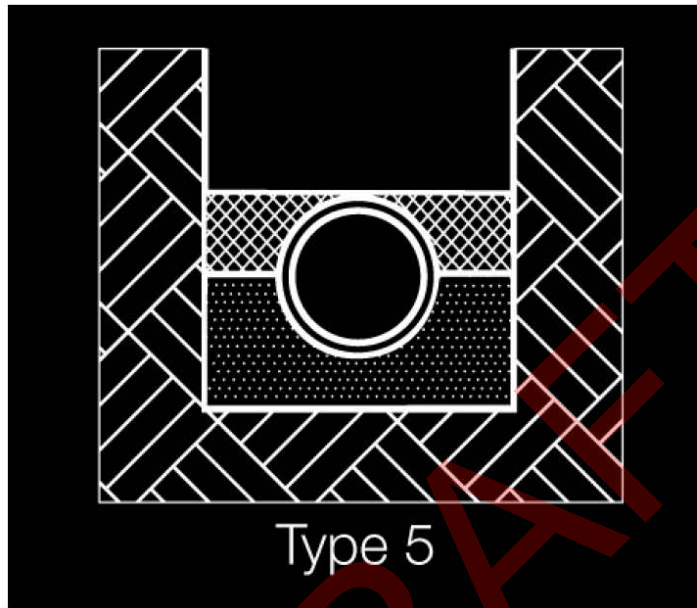

Pipe bedded to its centerline in compacted granular material, 4" minimum under pipe. Compacted granular or select material to top of pipe. (Approximately 90% Standard Proctor, AASHTO T-99.)

"Flat-bottom" is defined as undisturbed earth.

"Loose soil" or "select material" is defined as native soil excavated from the trench, free of rocks, foreign material and frozen earth.

Granular materials are defined per the AASHTO Soil Classification System (ASTM D3282) or the Unified Soil Classification System (ASTM D2487), with the exception that gravel bedding/backfill adjacent to the pipe is limited to 2" maximum particle size per ANSI/AWWA C600.

**APPENDIX 7B**  
**WATER LINE DETAILS**

DRAFT

DRAFT



TYPICAL 3/4" TO 1" METER

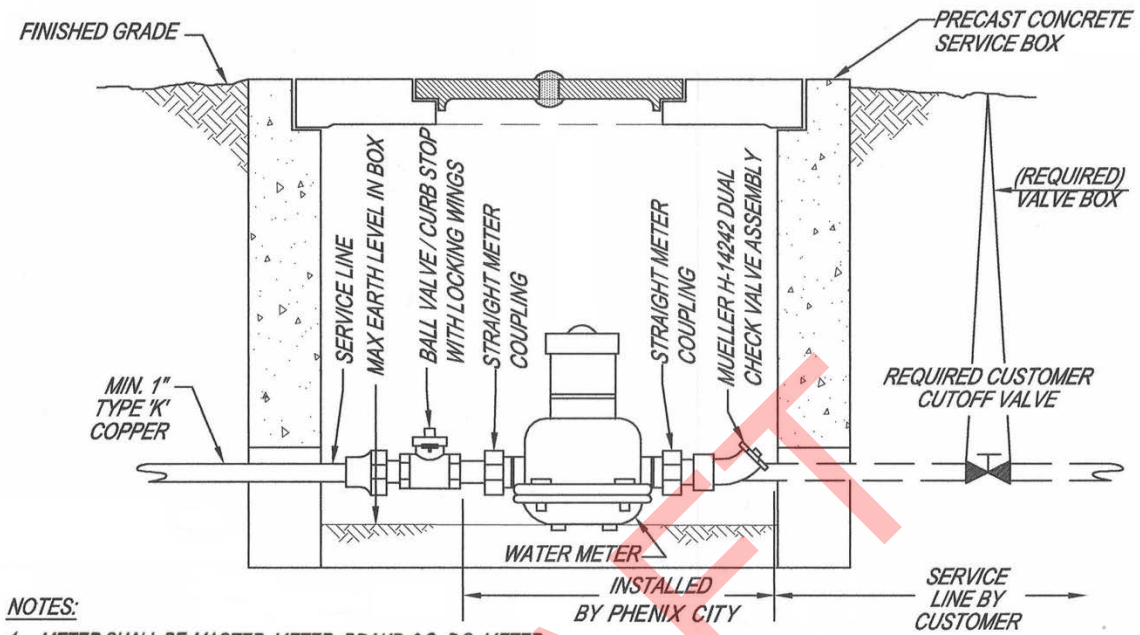

NOTES:

1. METER SHALL BE MASTER METER BRAND 3G DS METER.
2. PRESS FITTINGS ARE NOT ALLOWED.

DRAFT

DRAFT

## TYPICAL 1" SERVICE CONNECTION

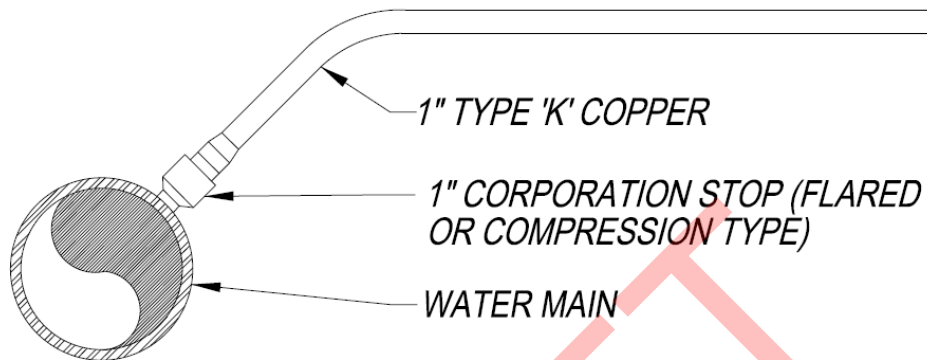

***NOTE:***

- 1. TYPICAL 1" SERVICE CONNECTION SHALL BE USED AT A MINIMUM FOR ALL 3/4" AND 1" METER INSTALLATIONS.***
- 2. PRESS FITTINGS ARE NOT ALLOWED.***

DRAFT

**TYPICAL END OF MAIN FOR FUTURE EXTENSION**

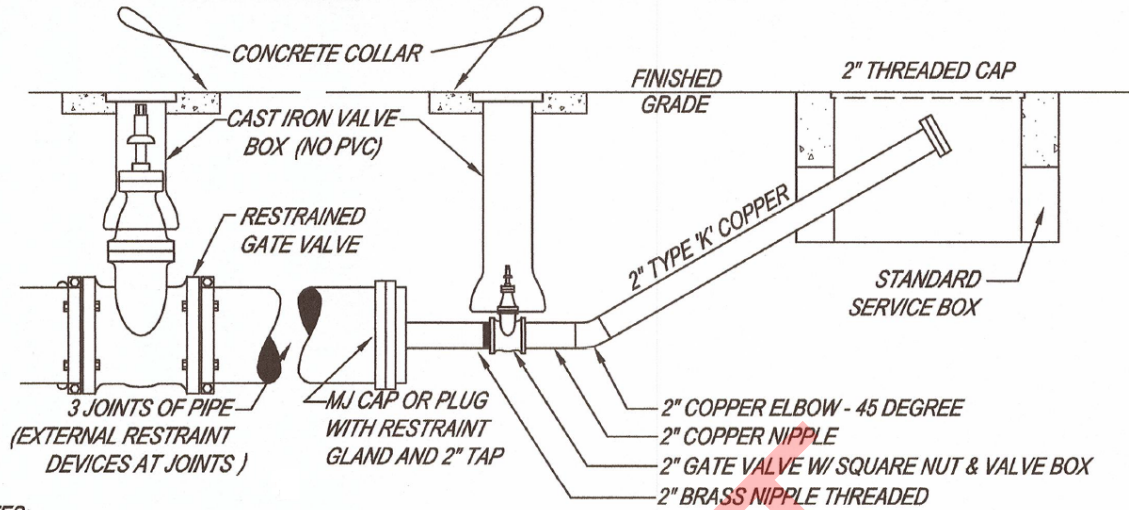

**NOTES:**

1. THE PREFERRED METHOD OF THRUST RESTRAINT SHALL BE THROUGH THE USE OF EXTERNALLY RESTRAINED JOINT DEVICES SUCH AS MEGA-LUGS IN LIEU OF CONCRETE BLOCKING. THE APPROPRIATE LENGTH OF RESTRAINT SHALL BE CALCULATED IN ACCORDANCE WITH THE MANUFACTURERS RECOMMENDATIONS.
2. BLOW OFF SHALL BE PIPED TO CURB AND GUTTER, WHERE POSSIBLE.
3. PRESS FITTINGS ARE NOT ALLOWED.

DRAFT

DRAFT

TYPICAL 1.5" TO 2" IRRIGATION METER

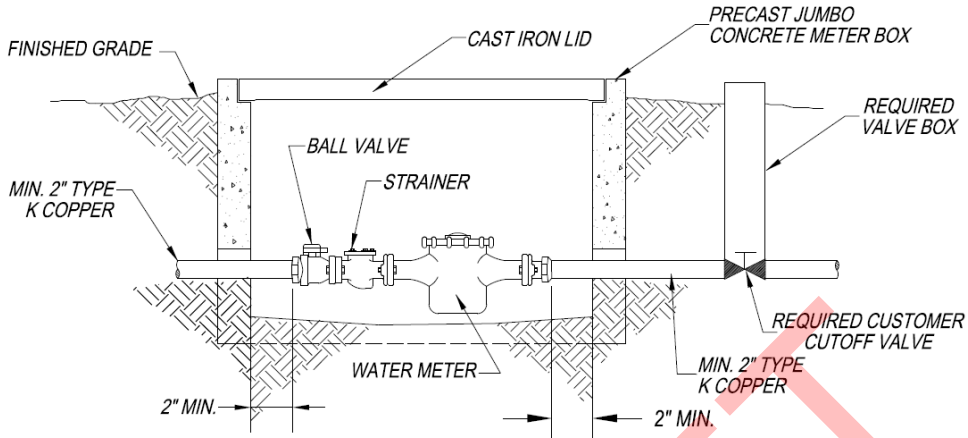

**NOTES:**

1. METER SHALL BE MASTER METER BRAND 3G DS METER.
2. STRAINER MUST BE SEPARATE FROM METER.
3. THE APPROPRIATE BACKFLOW ASSEMBLY IN ACCORDANCE WITH PHENIX CITY REQUIREMENTS SHALL BE INSTALLED IMMEDIATELY DOWNSTREAM OF THIS METER ASSEMBLY.

DRAWING

DRAFT



**TYPICAL 1.5" TO 2.0" METER VAULT W/ RPBA**

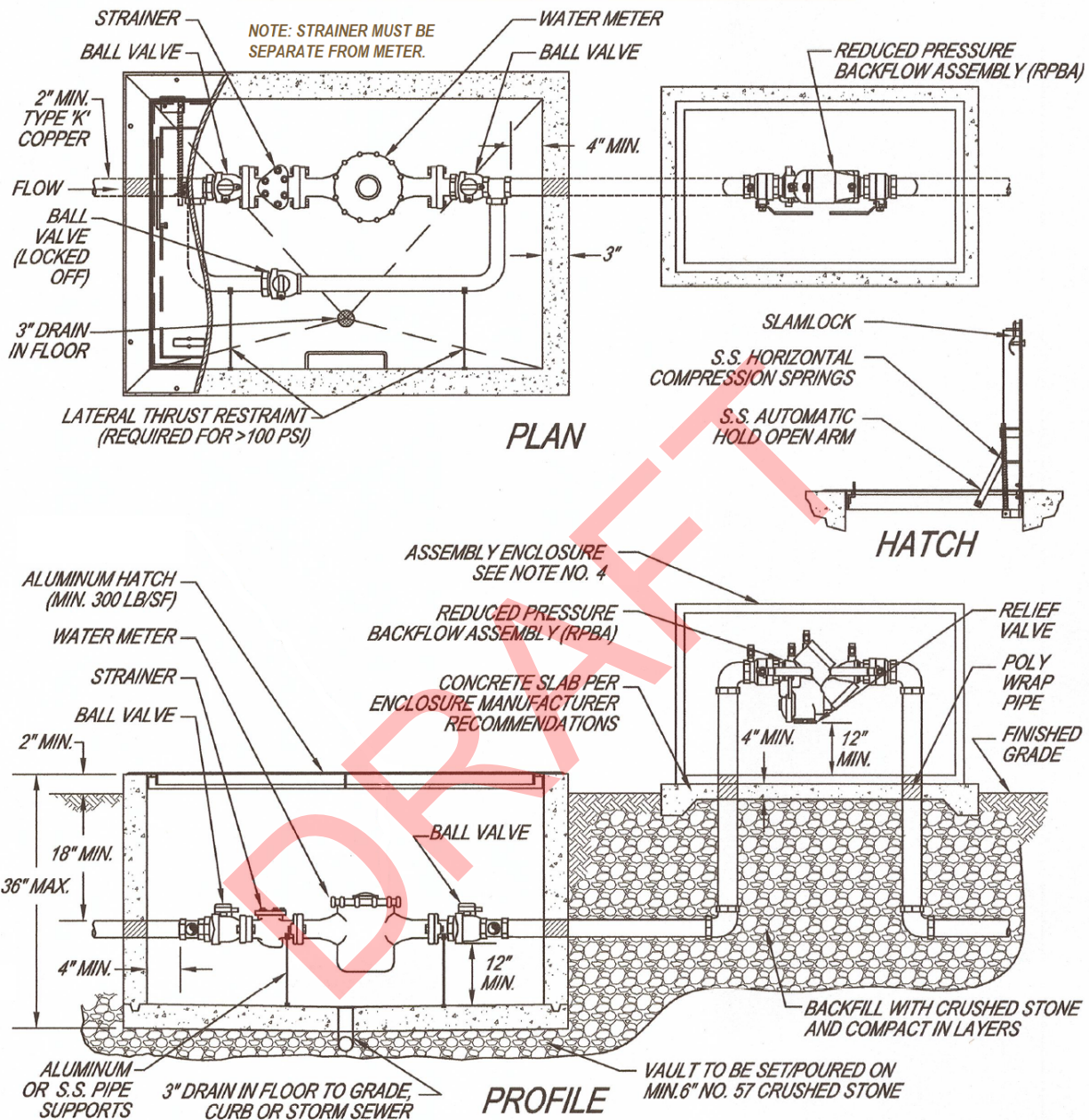

**NOTES:**

1. METER SHALL BE MASTER METER BRAND 3G D.S. METER.
2. RPBA SHALL BE MANUFACTURED BY AMES, WATTS, OR AN APPROVED EQUAL.
3. RPBA'S SHALL NOT BE BURIED OR INSTALLED IN BELOW GROUND VAULTS.
4. RPBA ENCLOSURES SHALL BE CONCRETE, REINFORCED ALUMINUM, OR FIBERGLASS CONSTRUCTION AND SHALL BE INSULATED AND/OR HEATED TO PROTECT AGAINST FREEZING. ENCLOSURES APPROVED FOR INSTALLATION INCLUDE: HYDROCOWL, HOT BOX, AND LOK BOX.
5. STRAINER MUST BE SEPARATE FROM METER.
6. PRESS FITTINGS ARE NOT ALLOWED.

DRAFT

TYPICAL 1.5" TO 2.0" METER VAULT W/ DCBA

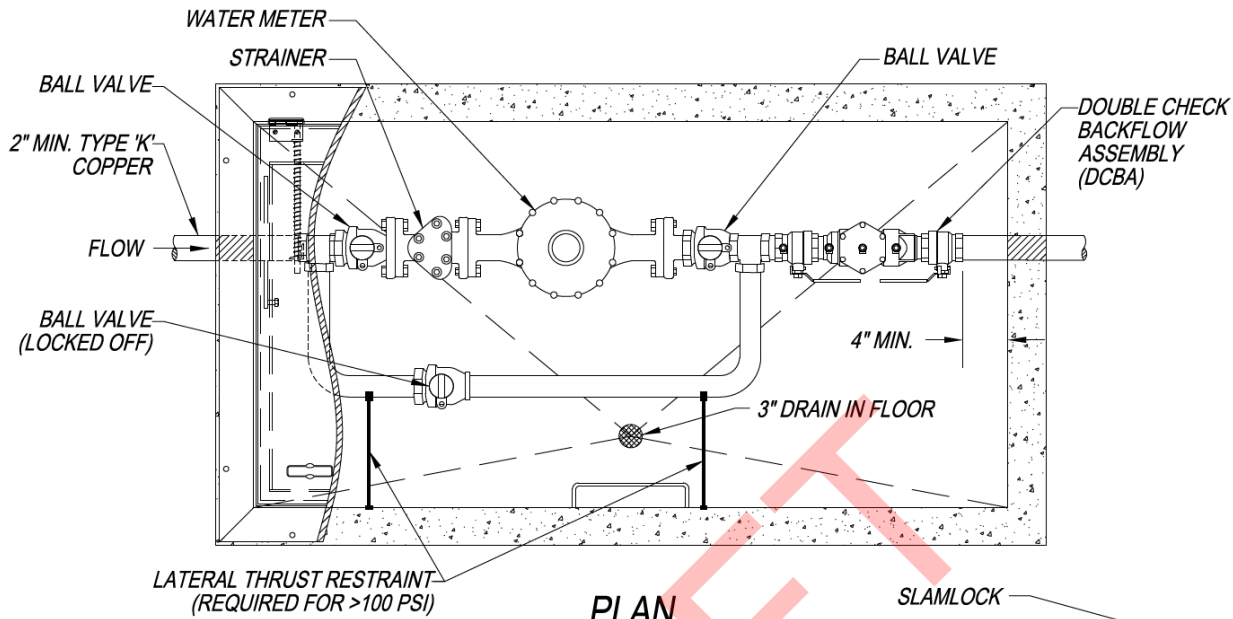

PLAN

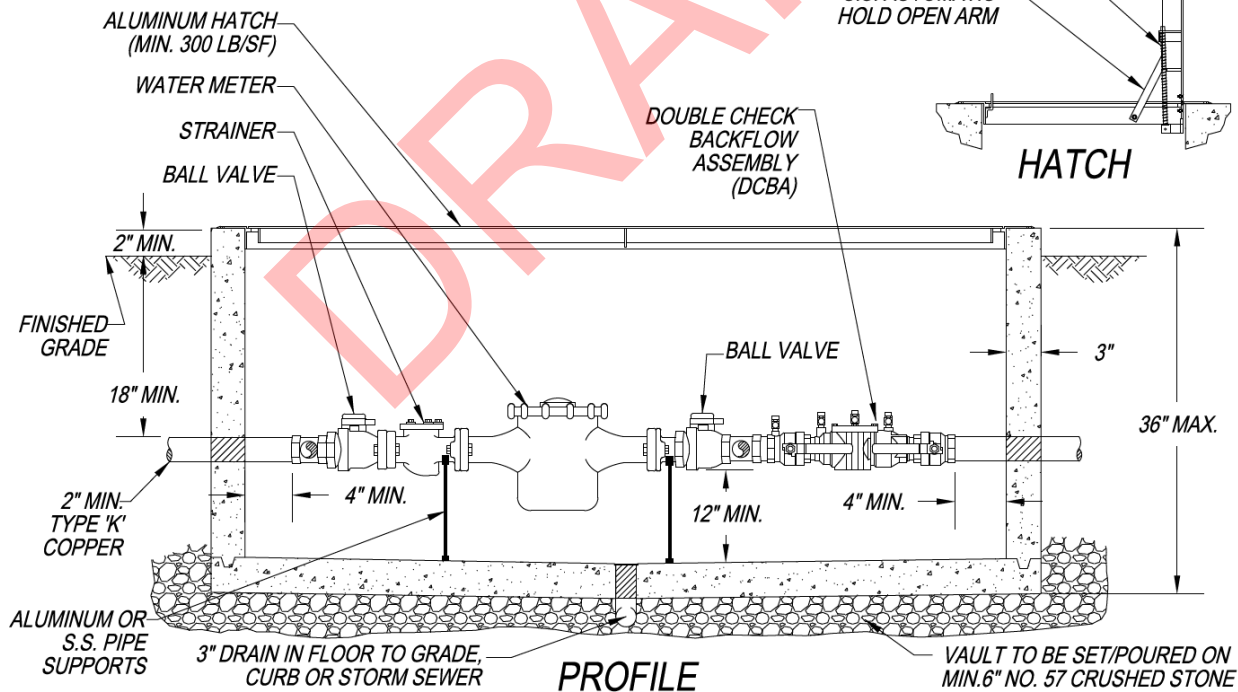
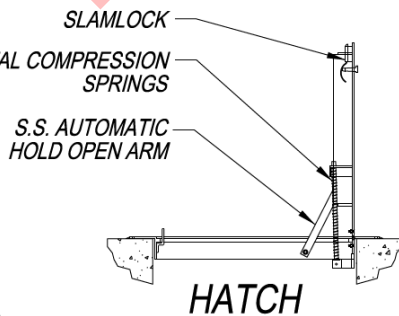

PROFILE

NOTES:

1. METER SHALL BE MASTER METER BRAND 3G DS METER.
2. STRAINER MUST BE SEPARATE FROM METER.
3. PRESS FITTINGS ARE NOT ALLOWED.

DRAFT

## TYPICAL 2" SERVICE CONNECTION

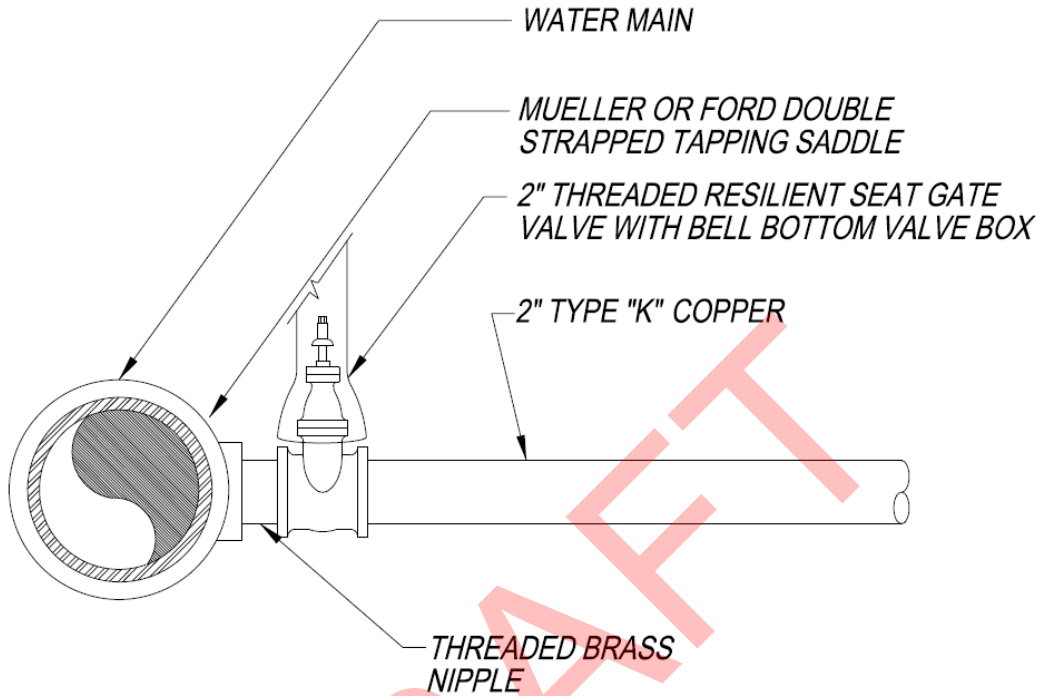

**NOTE:**

1. TYPICAL 2" SERVICE CONNECTION SHALL BE USED AT A MINIMUM FOR ALL 1-1/2" AND 2" METER INSTALLATIONS.

DRAFT



TYPICAL LARGE DOMESTIC METER VAULT (3" AND LARGER)

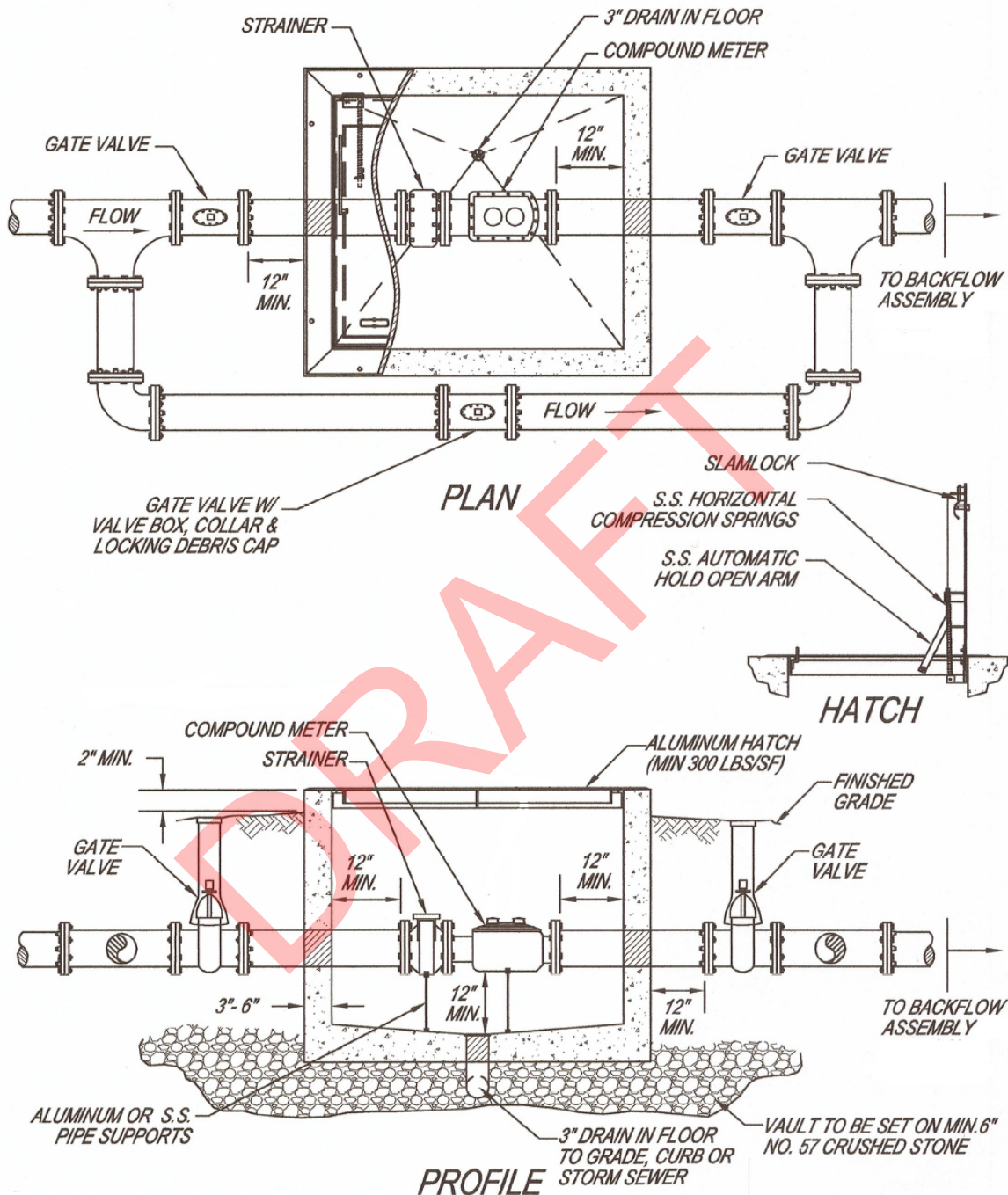

**NOTES:**

1. METER SHALL BE MASTER METER BRAND 3G DS METER.
2. STRAINER MUST BE SEPARATE FROM METER.
3. VAULTS SHALL BE INSPECTED BY THE CITY OF PHENIX CITY UTILITIES DEPARTMENT.
4. THE APPROPRIATE BACKFLOW ASSEMBLY IN ACCORDANCE WITH PHENIX CITY REQUIREMENTS SHALL BE INSTALLED IMMEDIATELY DOWNSTREAM OF THIS METER ASSEMBLY.

DRAFT



TYPICAL END OF MAIN IN CUL-DE-SAC

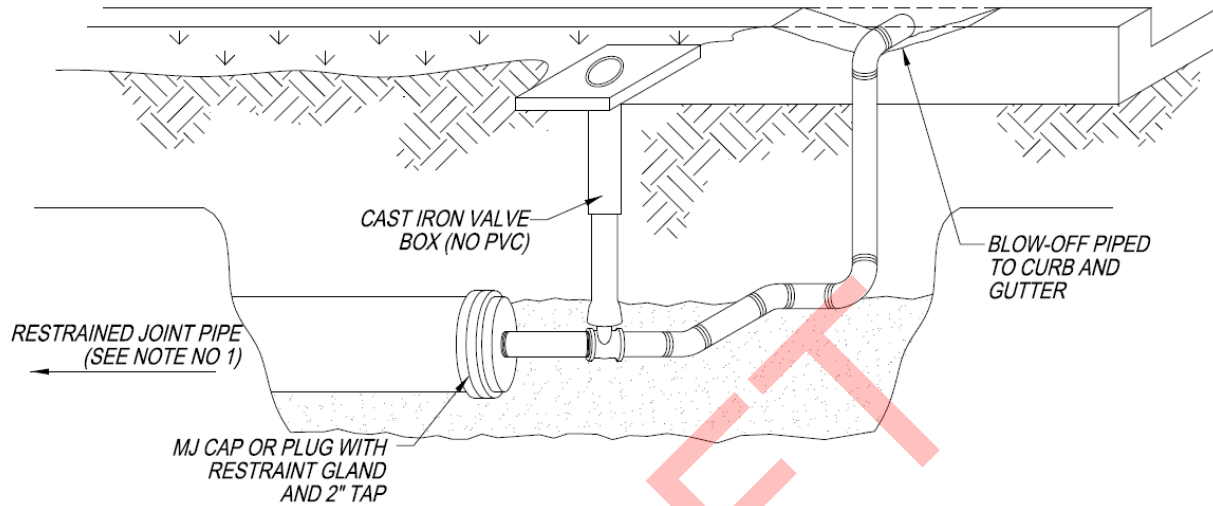

NOTES:

1. THE PREFERRED METHOD OF THRUST RESTRAINT SHALL BE THROUGH THE USE OF EXTERNALLY RESTRAINED JOINT DEVICES SUCH AS MEGA-LUGS IN LIEU OF CONCRETE BLOCKING. THE APPROPRIATE LENGTH OF RESTRAINT SHALL BE CALCULATED IN ACCORDANCE WITH THE MANUFACTURERS RECOMMENDATIONS.
2. PRESS FITTINGS ARE NOT ALLOWED.

DRAFT

**TYPICAL BORE ENCASEMENT**

CARRIER PIPE		SPACER	STEEL ENCASEMENT	
NOMINAL PIPE DIAMETER	STANDARD PIPE BELL O.D.*	CASING SPACER BAND WIDTH	MINIMUM CASING THICKNESS	MINIMUM CASING DIAMETER**
4	6.40	8	0.25	14
6	8.60	8	0.25	16
8	11.16	8	0.25	18
10	13.25	8	0.25	20
12	15.22	8	0.25	22
14	17.73	12	0.3125	24
16	19.86	12	0.3125	26
18	22.16	12	0.3125	30
20	24.28	12	0.3125	32
24	28.50	12	0.3125	36
30	34.95	12	0.5	42
36	41.37	12	0.5	48

ALL SIZES INDICATED ARE IN INCHES

\*PIPE BELL OUTSIDE DIAMETER BASED ON PRESSURE CLASS 350 DUCTILE IRON PIPE.

\*\*CASING DIAMETERS BASED ON BEING A MINIMUM OF 6 INCHES GREATER THAN THE OUTER DIAMETER OF THE JOINT BELL, TO THE NEAREST EVEN SIZE.

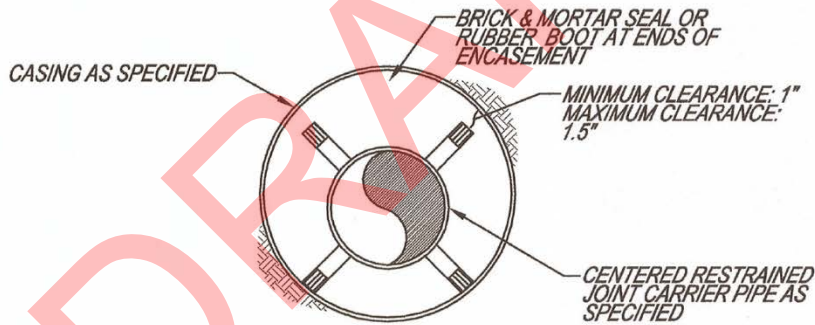

**CASING SECTION**

**NOTES**

1. ALL SPACER BANDS SHALL BE MADE FROM T-304 STAINLESS STEEL OF A MINIMUM 14 GAUGE THICKNESS.
2. ALL SPACERS SHALL HAVE A SYNTHETIC RUBBER OR PVC LINER TO INSULATE THE PIPELINE FROM THE SPACER.
3. ALL SPACERS SHALL HAVE 1.5" WIDE GLASS REINFORCED PLASTIC OR UHMW POLYMER RUNNERS TO INSULATE THE SPACER.
4. SPACERS TO BE MANUFACTURED BY CASCADE WATERWORKS MFG. CO. (PSI) PIPELINE SEAL AND INSULATOR, INC. OR EQUAL.
5. 4" THRU 12" DIAMETER PIPELINE SHALL USE 8" WIDE BANDS: GREATER THAN 12" DIAMETER PIPELINES SHALL USE 12" WIDE BANDS.
6. CENTERED RESTRAINED CASING SPACERS SHALL BE SPACED AT A MAXIMUM OF TEN FEET APART WITH A MINIMUM OF TWO SPACERS PER JOINT OF PIPE.
7. ALL PIPE SHALL BE COATED INSIDE AND OUT WITH AT LEAST ONE SHOP COAT OF AN APPROVED PRIMER PAINT. IN ADDITION, THE EXTERNAL SURFACE SHALL BE TREATED WITH ONE COAT OF ASPHALTUM PAINT, MEETING THE REQUIREMENTS OF FEDERAL SPECIFICATION TT-C-494B TYPE II, COMPOSITION G. FUSION-BONDED EPOXY COATING, MEETING THE REQUIREMENTS OF AWWA C213, MAY BE USED AS AN ALTERNATIVE TO THE SHOP COAT PRIMER AND ASPHALTUM PAINT.

DRAFT

CAST IN THIS FACE AND THE OPPOSITE  
FACE LETTERS 2" HIGH AS FOLLOWS:

FOR AIR RELEASE VALVES	FOR BLOWOFF VALVES	FOR VALVES
A	B	W
R	O	V
V	V	

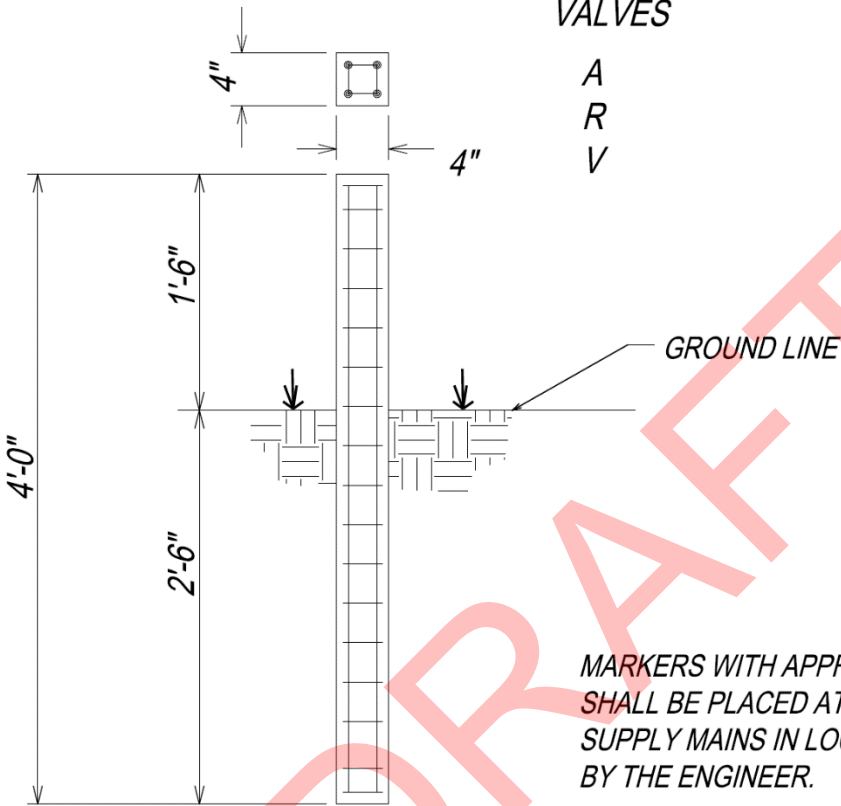

MARKERS WITH APPROPRIATE LETTERING  
SHALL BE PLACED AT ALL VALVES ON THE  
SUPPLY MAINS IN LOCATIONS DESIGNATED  
BY THE ENGINEER.

**PRECAST CONCRETE  
VALVE MARKER DETAIL**

NOT TO SCALE

DRAFT

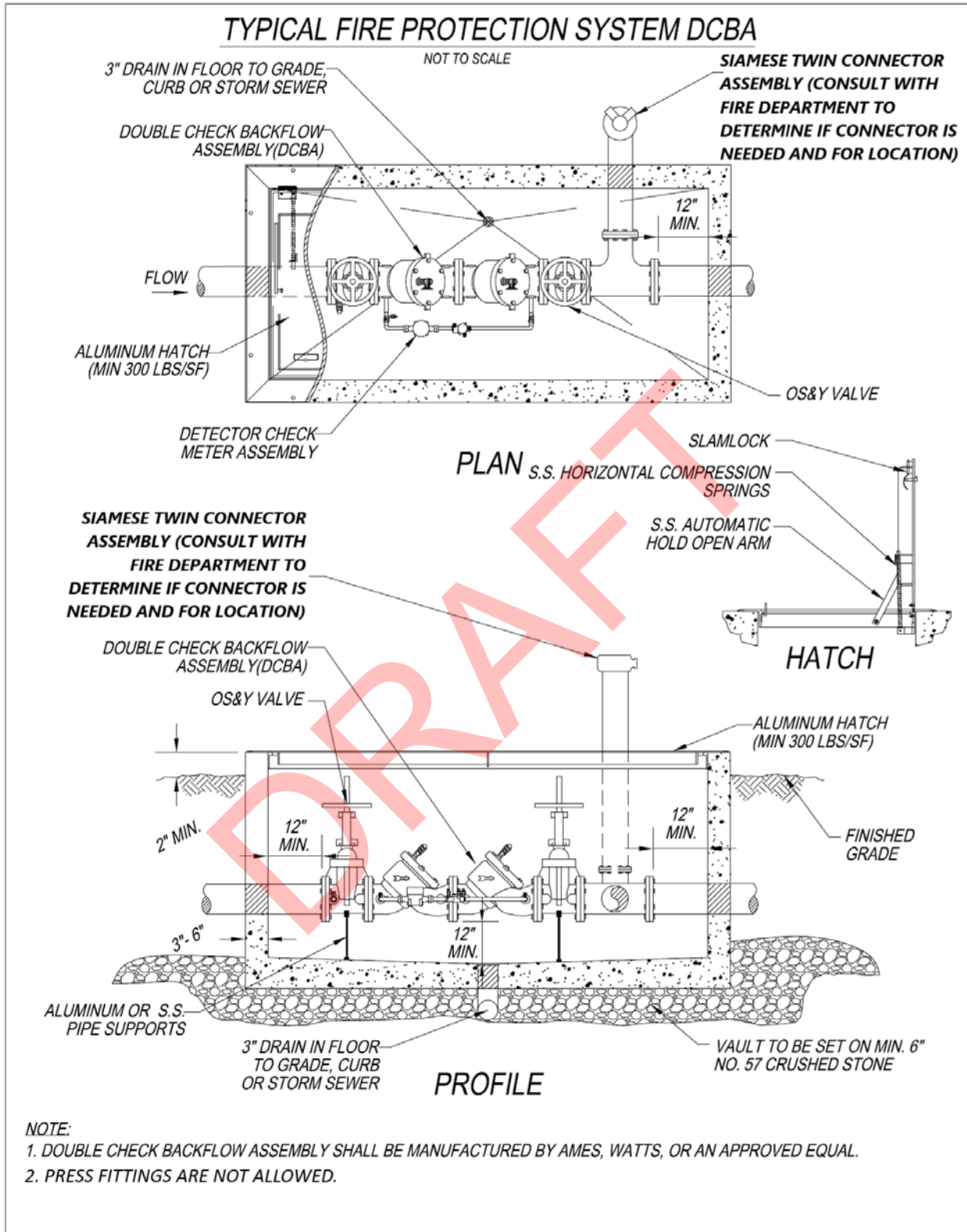

DRAFT



**TYPICAL DOUBLE CHECK BACKFLOW ASSEMBLY (DCBA)**

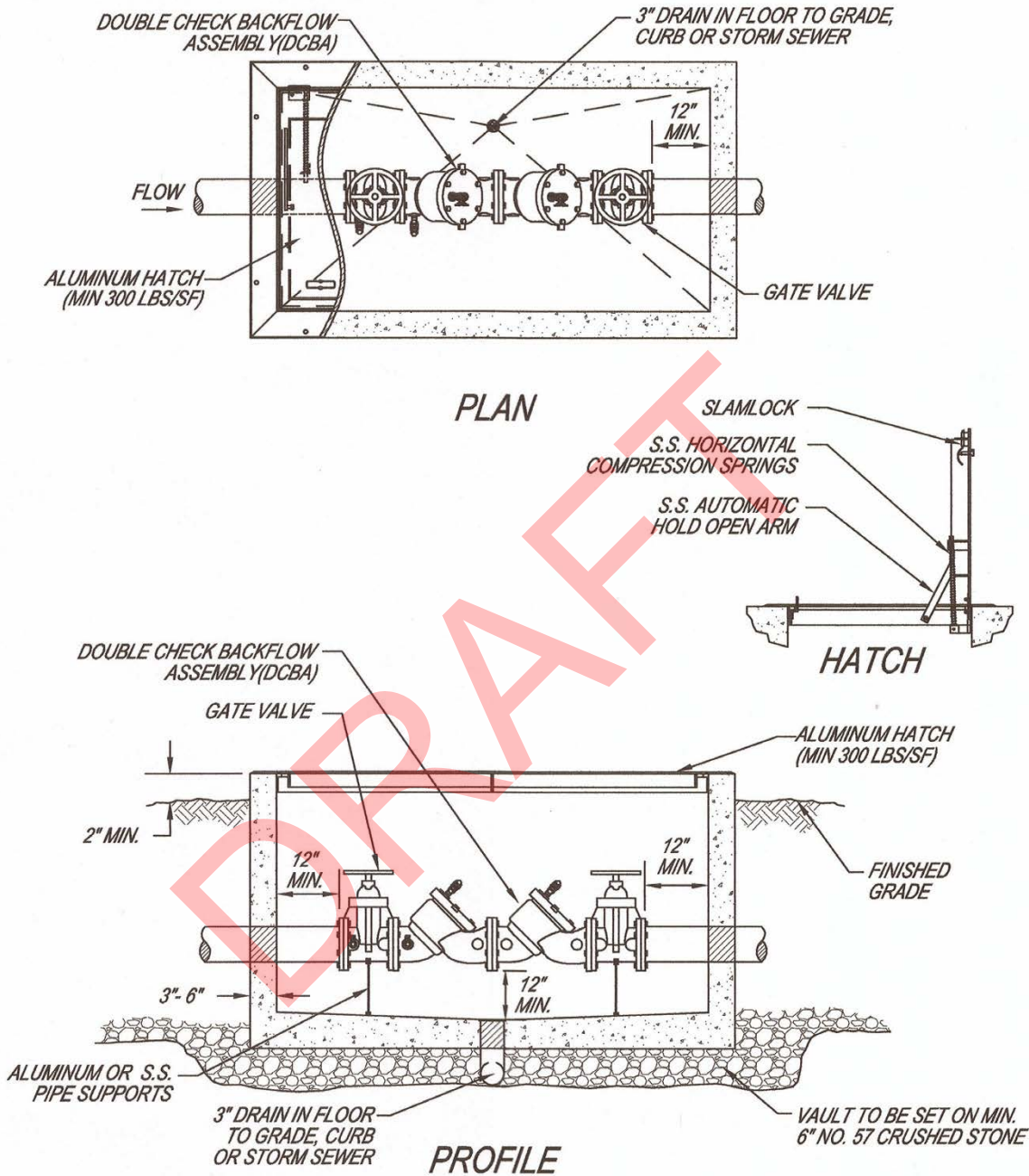

**NOTES:**

1. DOUBLE CHECK BACKFLOW ASSEMBLY SHALL BE MANUFACTURED BY AMES, WATTS, OR AN APPROVED EQUAL.

DRAFT

**TYPICAL DEADMAN THRUST RESTRAINT**

NOT TO SCALE

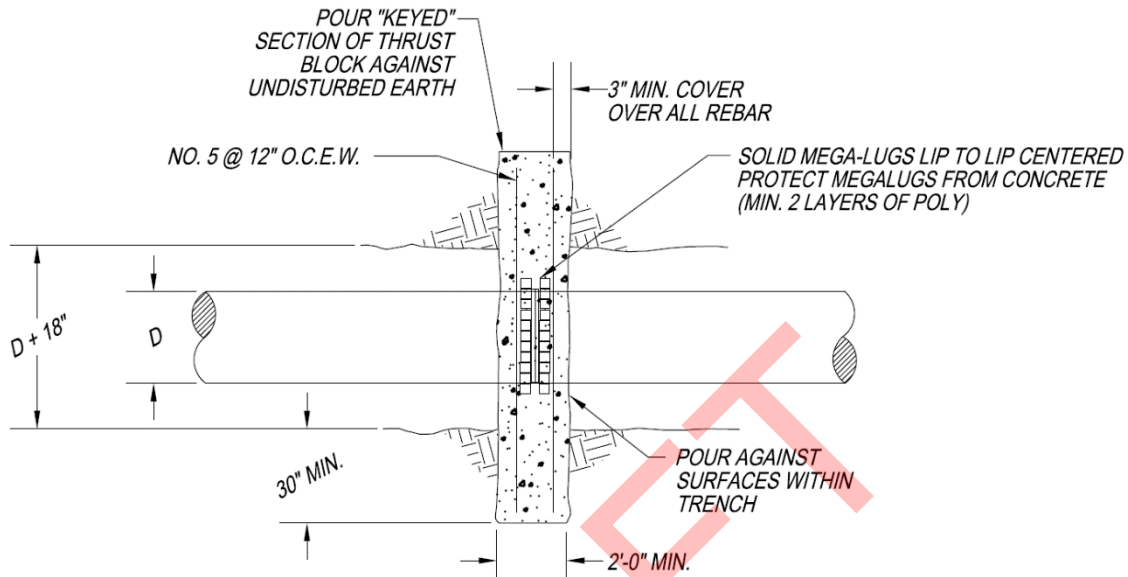

**PLAN**

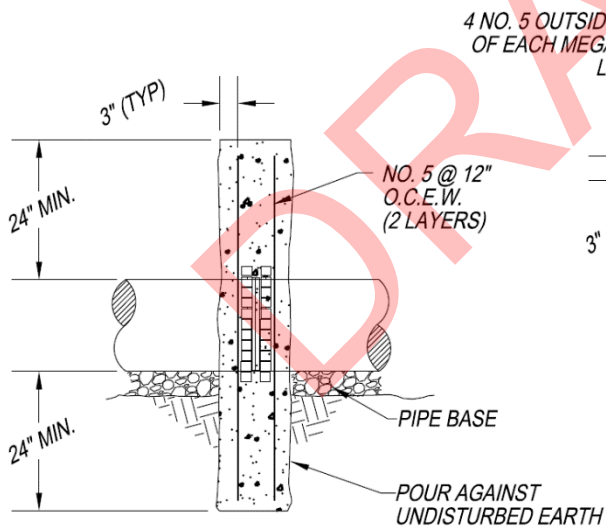

**PROFILE**

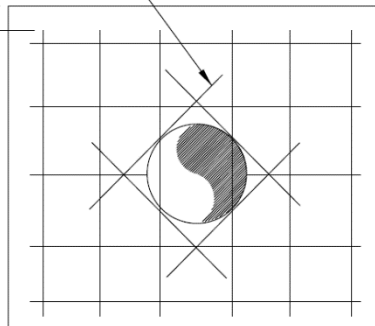

**FRONT**

**NOTES:**

1. DEADMAN TO BE CENTERED ON FULL JOINT OF PIPE
2. ALL CONCRETE SHALL BE CLASS "A" (4000 PSI) AS FOLLOWS:
  - i. MINIMUM COMPRESSIVE STRENGTH AT 28 DAYS: 4000 PSI FOR 5 CONSECUTIVE SPECIMENS AND 3600 PSI FOR ANY ONE SPECIMEN.
  - ii. 6 BAGS MINIMUM AND 8 BAGS OF CEMENT PER CUBIC YARD OF CONCRETE.
  - iii. 5 GALLONS OF WATER MAXIMUM PER CUBIC FOOT OF CEMENT.
  - iv. MINIMUM 5% AND MAXIMUM 7% OF AIR ENTRAINED IN FRESH MIX.
3. NO CALCIUM CHLORIDE CURING ACCELERATOR ALLOWED.
4. APPLICABLE FOR UP TO AND INCLUDING 12" DIAMETER PIPE. MAY BE USED FOR PIPES ABOVE 12" DIAMETER ON A CASE BY CASE BASIS.
5. TO BE USED ON EXISTING DUCTILE IRON OR CAST IRON PIPE IN GOOD CONDITION.

DRAFT

**TYPICAL FIRE HYDRANT INSTALLATION**

NOT TO SCALE

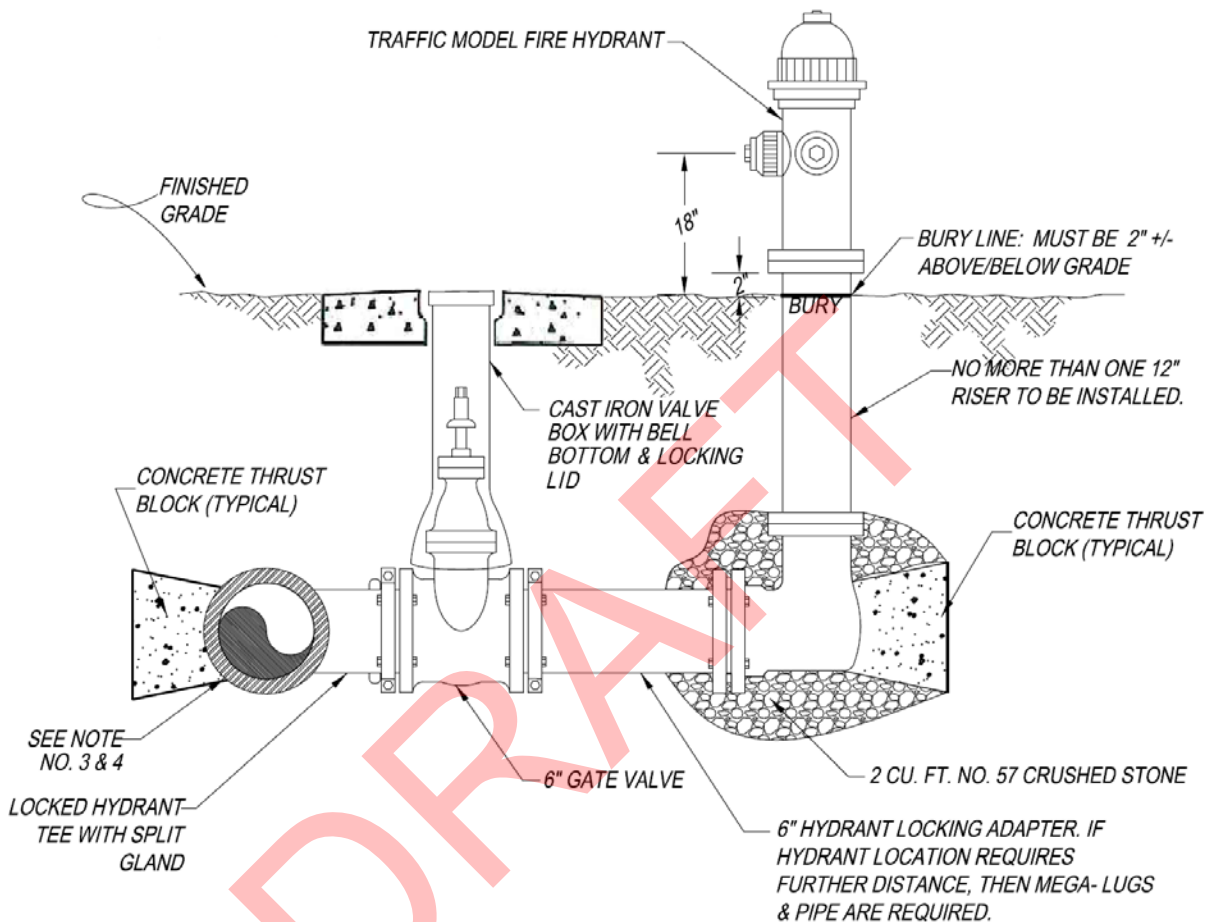

**NOTES:**

1. ALL FIRE HYDRANTS SHALL HAVE NATIONAL STANDARD THREADS, 4 1/2-INCH STEAMER & 2 1/2-INCH HOSE NOZZLE, AND SHALL BE MUELLER CENTURION, OR AMERICAN DARLING B-84-B, OR APPROVED EQUAL. BRONZE TO BRONZE SEATED. EPOXY COATED SHOES. WEATHER CAPS SHALL NOT BE MADE OF RUBBER.
2. ALL FIRE HYDRANTS SHALL BE LEVELED AND PLUMBED DURING INSTALLATION.
3. ALL MECHANICAL JOINT FITTINGS THAT REQUIRE THRUST BLOCKS SHALL BE WRAPPED IN PLASTIC. CONCRETE SHALL NOT BE POURED OVER JOINTS.
4. USE MEGA-LUGS BETWEEN HYDRANT AND GATE VALVE.
5. HYDRANT LOCKING TEE TO BE USED IN LIEU OF STANDARD M.J. TEE ON ALL FIRE HYDRANT CONNECTIONS.

DRAFT



**TYPICAL FIRE / DOMESTIC METER VAULT (4" AND LARGER)**

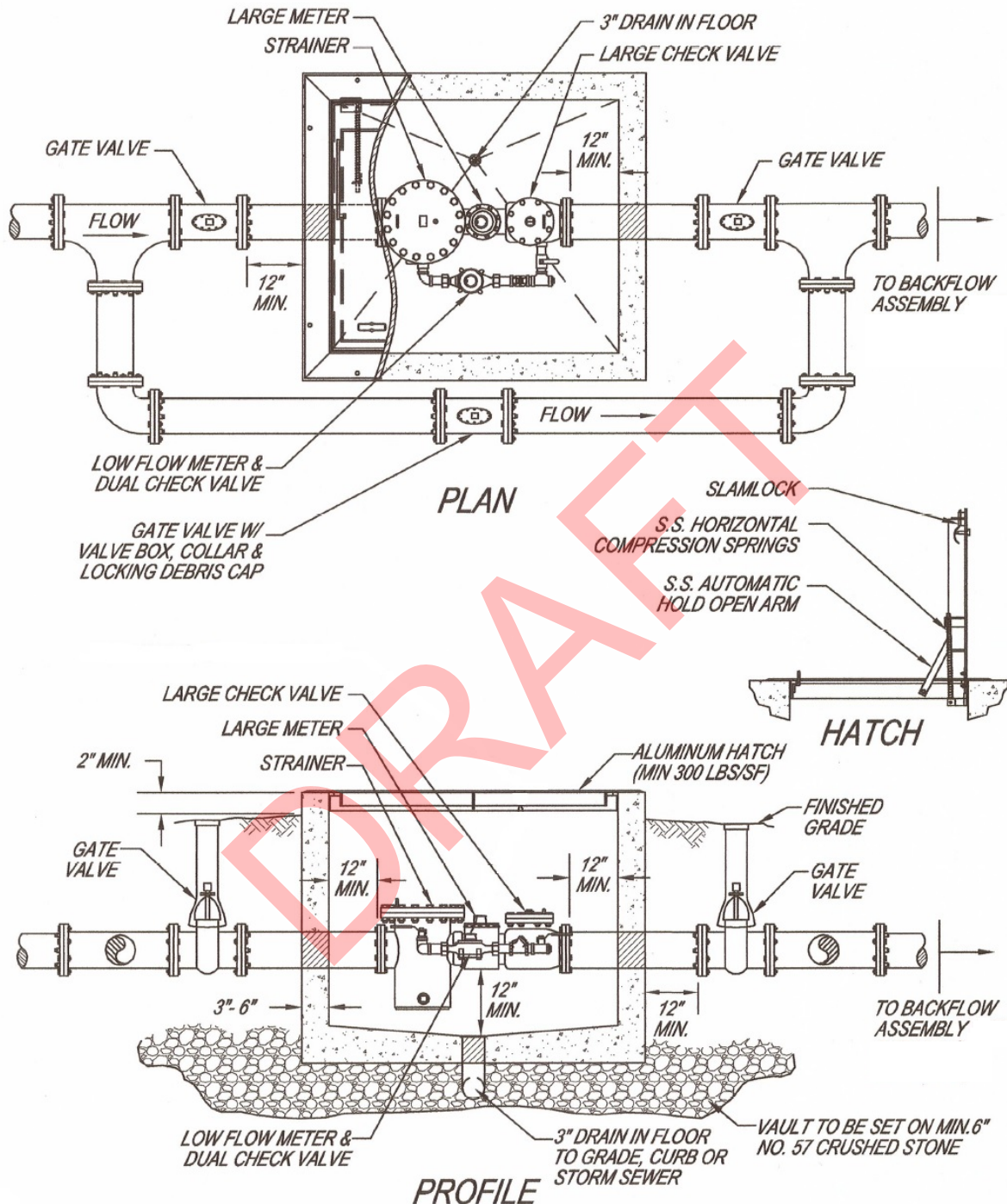

**NOTES:**

1. ALL METERS SHALL BE MASTER METER BRAND AND BE COMPATABLE WITH 3G DS RADIO READING SYSTEM.
2. VAULTS SHALL BE INSPECTED BY THE CITY OF PHENIX CITY UTILITIES DEPARTMENT.
3. THE APPROPRIATE BACKFLOW ASSEMBLY IN ACCORDANCE WITH PHENIX CITY REQUIREMENTS SHALL BE INSTALLED IMMEDIATELY DOWNSTREAM OF THIS METER ASSEMBLY.
4. PRESS FITTINGS ARE NOT ALLOWED.

DRAFT



TYPICAL MULTIPLE METER VAULT

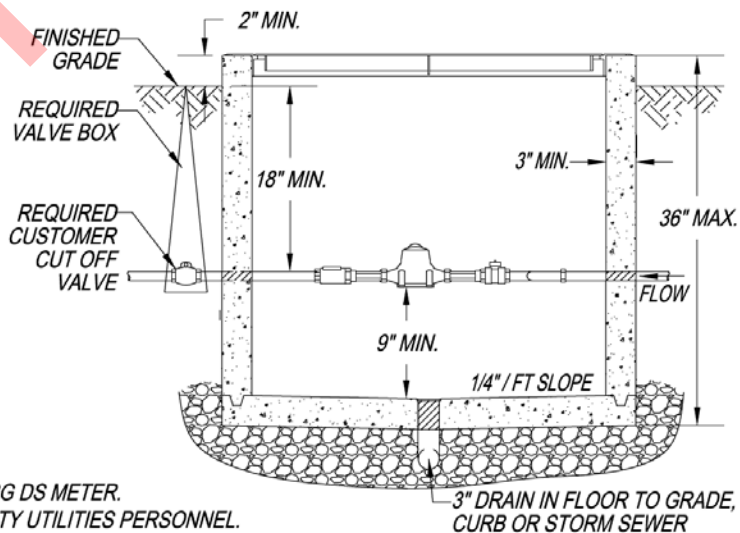
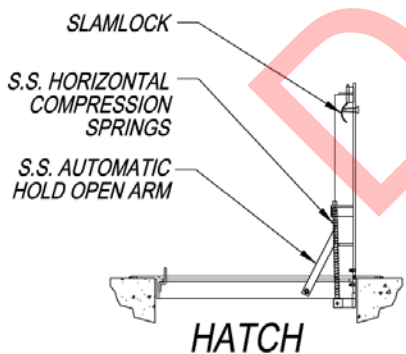
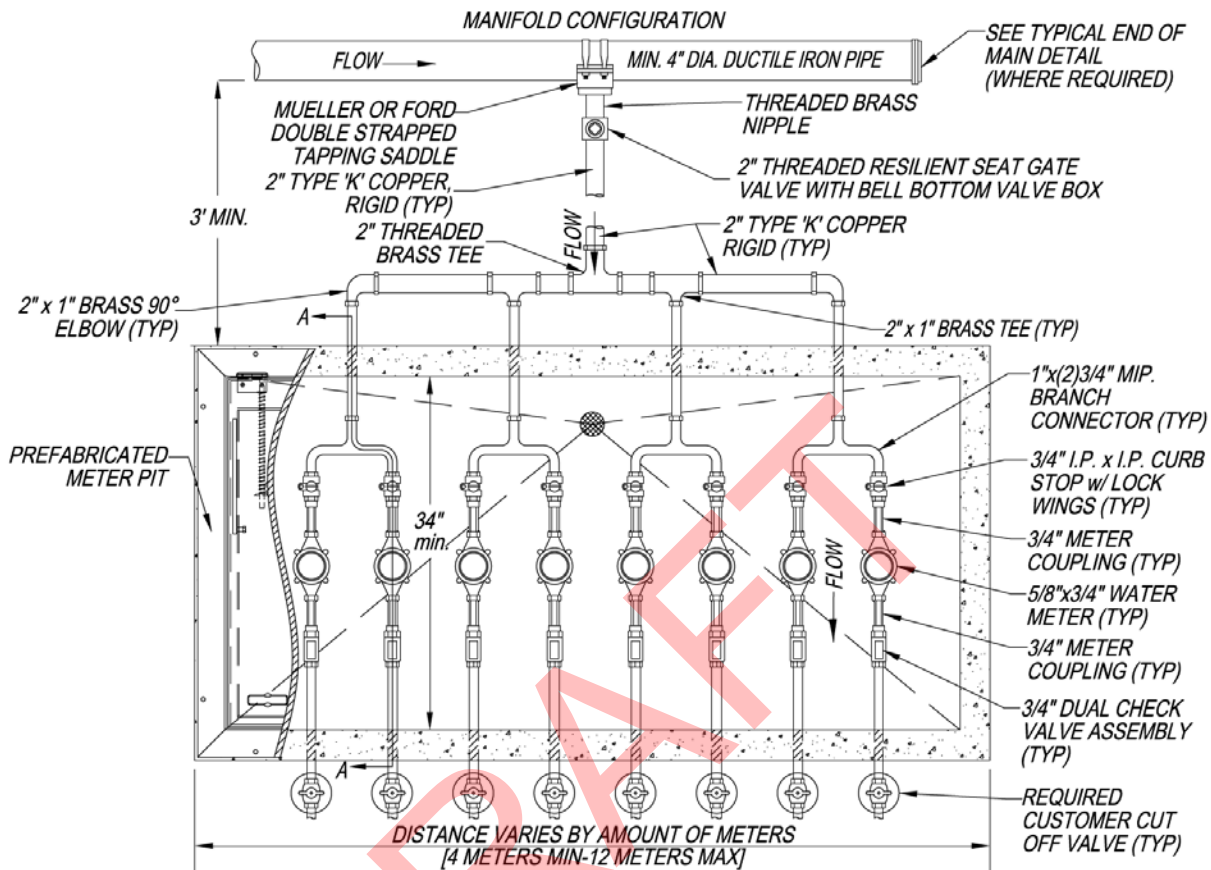

- NOTES:
1. METERS SHALL BE MASTER METER BRAND 3G DS METER.
  2. VAULTS SHALL BE INSPECTED BY PHENIX CITY UTILITIES PERSONNEL.
  3. PRESS FITTINGS ARE NOT ALLOWED.

DRAFT

**TYPICAL REDUCED PRESSURE BACKFLOW ASSEMBLY**

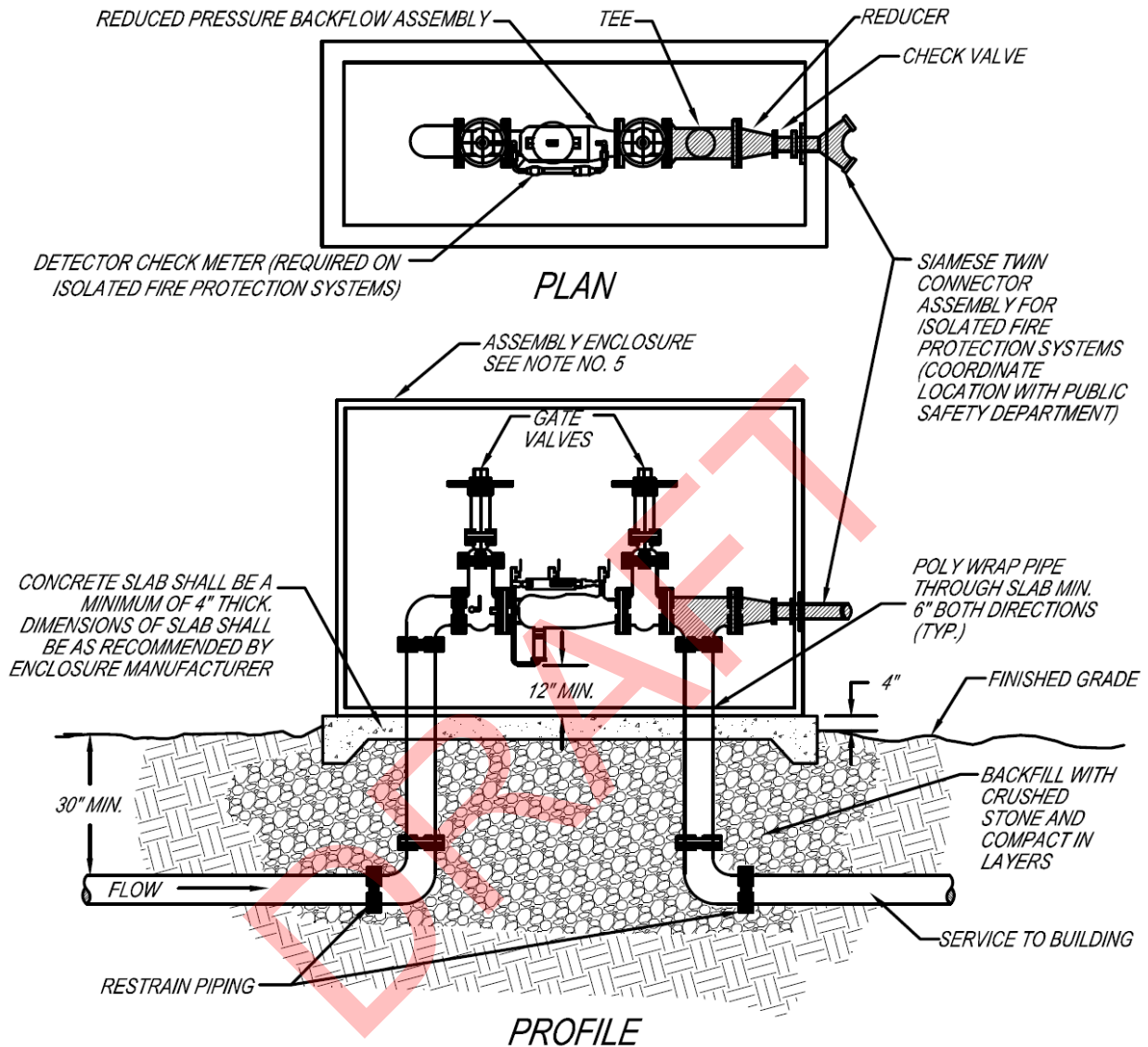

**NOTES:**

1. EMERGENCY BYPASS IS NOT ALLOWED UNLESS A COMPLETELY REDUNDANT SYSTEM IS INSTALLED.
2. RPBA's SHALL NOT BE BURIED OR INSTALLED IN BELOW GROUND VAULTS. THE DEVICE SHALL BE INSTALLED ABOVE GROUND TO PREVENT THE RELIEF OR VENT OPENING FROM BEING SUBMERGED AT ANY TIME.
3. RPBA ASSEMBLY ENCLOSURES SHALL BE CONCRETE, REINFORCED ALUMINUM, OR FIBERGLASS CONSTRUCTION, PROVIDING ACCESS THROUGH DOORS AND/OR HINGED LID FOR TESTING AND MAINTENANCE PURPOSES. THE ENCLOSURES SHALL BE "LOCKABLE" TO PROTECT AGAINST VANDALISM. THE ENCLOSURES SHALL HAVE DRAIN OPENINGS SIZED TO ACCOMMODATE THE MAXIMUM DISCHARGE UNDER THE MOST SEVERE CONDITIONS. DISCHARGE POINTS SHALL BE PROTECTED AGAINST INTRUSION OF EITHER WIND, DEBRIS OR ANIMALS.
4. RPBA ENCLOSURE SYSTEMS SHALL BE CONSTRUCTED, INSTALLED, AND INSULATED/HEATED SO AS TO ENSURE AGAINST FREEZING. ENCLOSURES APPROVED FOR INSTALLATION INCLUDE: HYDROCOWL, HOT BOX, AND LOK BOX.
5. RPBA SHALL BE MANUFACTURED BY AMES, WATTS, OR AN APPROVED EQUAL.
6. PRESS FITTINGS ARE NOT ALLOWED.

DRAFT

## TAPPING SLEEVE & VALVE ASSEMBLY

NOT TO SCALE

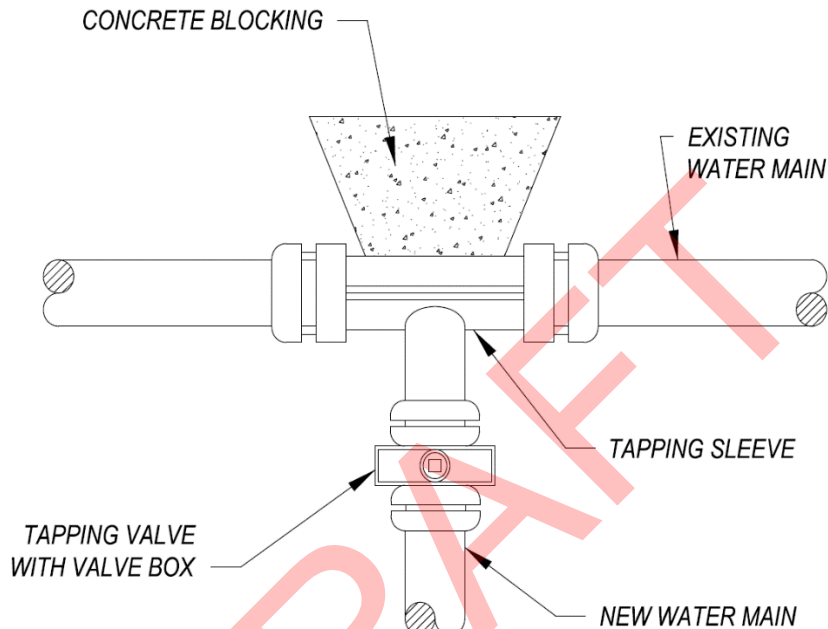

**NOTES:**

1. TAPPING SLEEVE SHALL BE FABRICATED OF TYPE 304 OR 316 S.S. AND PROVIDE A 360° SEAL AROUND EXISTING PIPE WITH FULL CIRCUMFERENTIAL SEAL.
2. TAPPING SLEEVE SHALL BE MUELLER H-304, ROMAC ST III OR APPROVED EQUAL.
3. ALL MATERIALS USED IN THE POTABLE WATER SYSTEM MUST BE NSF61 AND NSF372 CERTIFIED AND MEET THE LATEST FEDERAL SAFE DRINKING WATER ACT REQUIREMENTS.

DRAFT

**TYPICAL CONCRETE THRUST BLOCK DESIGN**

NOT TO SCALE

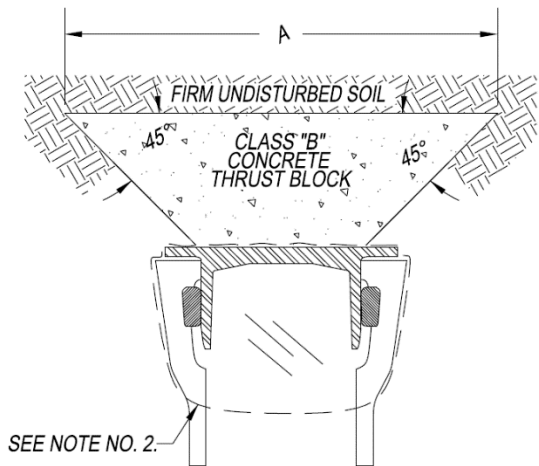

**BELL JOINT PLUG  
UNRESTRAINED TYPE**

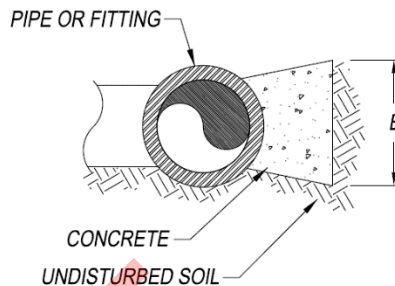

**SIDE VIEW**

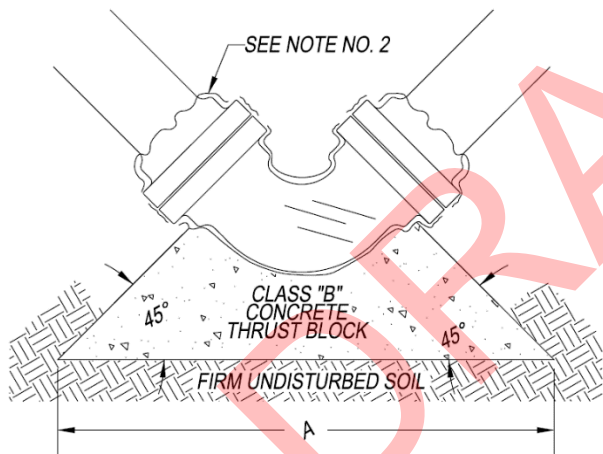

**TYPICAL BEND THRUST BLOCK**

**BEARING AREA**

AREA (SF) AGAINST UNDISTURBED SOIL

Size	Tee, Wye, Plug or 90° Bend	45° Bend	22.5° Bend	11.5° Bend
4"	1	1	1	1
6"	3	2	1.5	1
8"	5	3	2	1.5
10"	9	5	3	2
12"	12	8	4	3
16"	22	12	5	4

BASED ON 2500 LB/ft.<sup>2</sup> SOIL  
 BEARING AREA (SF) = A x B    1 < (A / B) < 3  
 < 100 PSI STATIC PRESSURE ( 600 MSL OR HIGHER)

**NOTES:**

1. 45 DEGREE ANGLES REQUIRED FOR ALL THRUST BLOCKS.
2. NON STANDARD THRUST BLOCKING WILL REQUIRE SPECIAL DETAILING PROVIDED BY A LICENSED ENGINEER AND APPROVED BY THE CITY OF PHENIX CITY.
3. ALL MECHANICAL JOINT FITTINGS THAT REQUIRE THRUST BLOCKS SHALL BE WRAPPED IN PLASTIC. CONCRETE SHALL NOT BE Poured OVER JOINTS.
4. CLASS "B" CONCRETE SHALL BE AS DEFINED AS FOLLOWS:
  - i. MINIMUM COMPRESSIVE STRENGTH AT 28 DAYS: 2000 PSI FOR 5 CONSECUTIVE SPECIMENS AND 1600 PSI FOR ANY ONE SPECIMEN.
  - ii. 4.5 BAGS MINIMUM AND 5.5 BAGS OF CEMENT PER CUBIC YARD OF CONCRETE.
  - iii. 7.5 GALLONS OF WATER MAXIMUM PER CUBIC FOOT OF CEMENT.
  - iv. NO AIR ENTRAINED IN FRESH MIX.
5. THE APPROPRIATE LENGTH OF RESTRAINT SHALL BE CALCULATED IN ACCORDANCE WITH THE MANUFACTURER'S RECOMMENDATIONS.

DRAFT



**TYPICAL CONCRETE THRUST BLOCK LAYOUT**

NOT TO SCALE

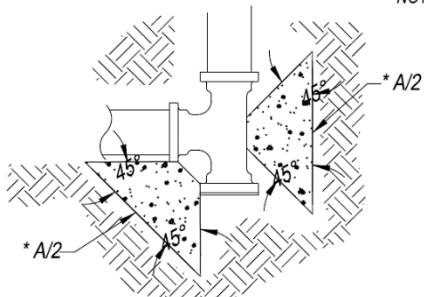

**PLUGGED TEE**

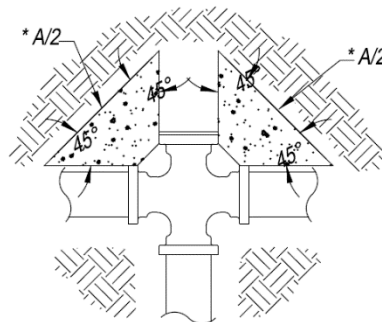

**PLUGGED CROSS**

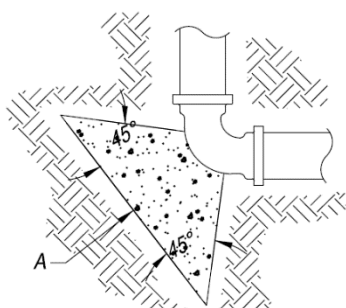

**BEND**

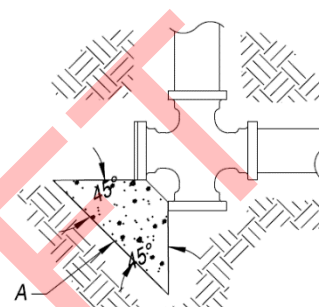

**PLUGGED CROSS**

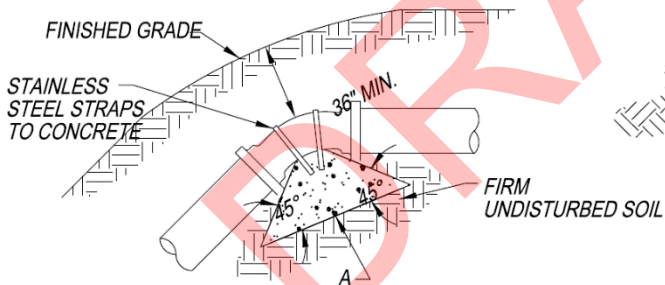

**VERTICAL BEND**  
(AGAINST DISTURBED SOIL)

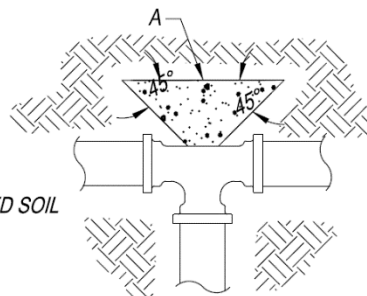

**TEE**

**NOTES:**

1. 45 DEGREE ANGLES REQUIRED FOR ALL THRUST BLOCKS.
2. NON STANDARD THRUST BLOCKING WILL REQUIRE SPECIAL DETAILING PROVIDED BY A LICENSED ENGINEER AND APPROVED BY THE CITY OF PHENIX CITY.
3. ALL MECHANICAL JOINT FITTINGS THAT REQUIRE THRUST BLOCKS SHALL BE WRAPPED IN PLASTIC. CONCRETE SHALL NOT BE Poured OVER JOINTS.
4. CLASS "B" CONCRETE SHALL BE AS DEFINED AS FOLLOWS:
  - i. MINIMUM COMPRESSIVE STRENGTH AT 28 DAYS: 2000 PSI FOR 5 CONSECUTIVE SPECIMENS AND 1600 PSI FOR ANY ONE SPECIMEN.
  - ii. 4.5 BAGS MINIMUM AND 5.5 BAGS OF CEMENT PER CUBIC YARD OF CONCRETE.
  - iii. 7.5 GALLONS OF WATER MAXIMUM PER CUBIC FOOT OF CEMENT.
  - iv. NO AIR ENTRAINED IN FRESH MIX.
5. THE APPROPRIATE LENGTH OF RESTRAINT SHALL BE CALCULATED IN ACCORDANCE WITH THE MANUFACTURER'S RECOMMENDATIONS.

DRAFT

TYPICAL VALVE BOX INSTALLATION

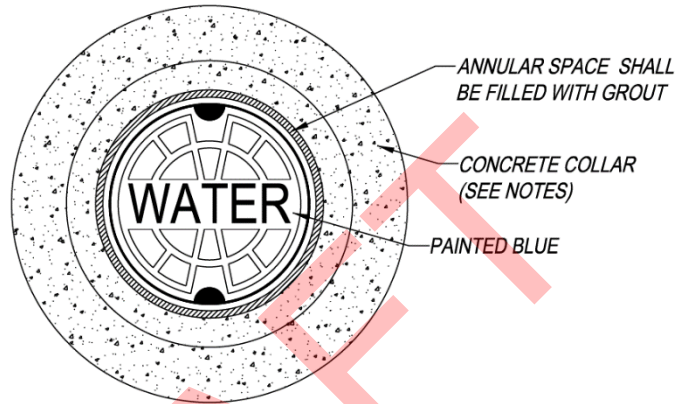
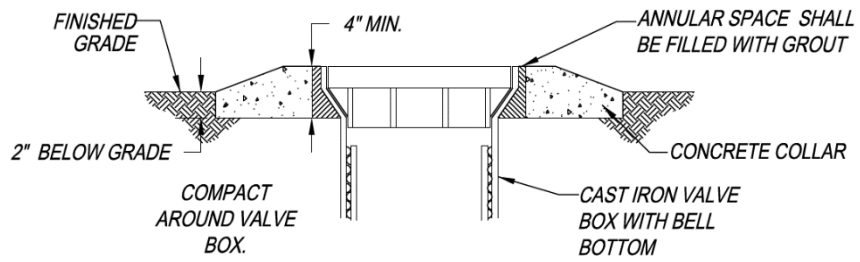

NOTE:

1. CONCRETE COLLAR MAY BE CAST-IN-PLACE OR PRECAST AND MAY BE ROUND OR SQUARE IN SHAPE.
2. CONCRETE COLLAR SHALL BE A MIN. 4" THICK.
3. LOCKING LIDS REQUIRED ON ALL VALVES ON FIRE LINES.

DRAFT

DRAFT

**APPENDIX 7C**  
**SANITARY SEWER SPECIFICATIONS**

DRAFT

DRAFT



**PHENIX CITY**  
*Alabama*

**UTILITIES DEPARTMENT**

Physical Address: 1119 Broad Street  
Phenix City, AL 36867

Mailing Address: P.O. Box 760  
Phenix City, AL 36868

Ph: 334-448-2880 | Fx: 334-291-4742 | phenixcityal.us

**DR. R. GRIFF GORDY**  
Mayor Pro Tem / At Large

**STEVE BAILEY**  
Councilmember District 1

**EDDIE N. LOWE**  
Mayor

**VICKEY CARTER JOHNSON**  
Councilmember District 2

**ARTHUR L. DAY, JR.**  
Councilmember District 3

WALLACE B. HUNTER, City Manager  
MELONY LEE, City Clerk  
CHARLES D. WOODY II, Utilities Director

## PREFACE

Presented herein are Standard Specifications for the Sanitary Sewer System for the City of Phenix City, Alabama, hereinafter known as the "City". These specifications are to ensure the quality of material, workmanship, and compatibility of products with the existing materials installed in the City.

Sanitary sewer infrastructure installed in conjunction with private development, extension of existing service, private upgrading of existing service, or for any other purpose to be tied to sanitary sewer infrastructure being operated and maintained by the "City" shall conform to these specifications. It shall be the responsibility of the Owner/Developer/Contractor to ensure that all materials and methods of installation of all sanitary sewer infrastructure shall strictly conform to these specifications. Any deviations not approved by the City, in writing, shall be grounds for rejection of any part or all sanitary sewer infrastructure installed. Rejection, at the City's discretion, shall result in the sanitary sewer infrastructure in question not being connected to sanitary sewer infrastructure owned and/or operated by the City.

Prior to any laying operation, the Owner/Developer shall submit to the City for approval a set of plans showing size and location of all proposed material and equipment and submittal data showing manufacture and model number of all material and equipment to be used. The submittal of material and plans, and the approval thereof, in no way relieves the Owner/Developer/Contractor of his responsibility to adhere to these specifications. Upon delivery of material/equipment, the Owner/Developer/Contractor shall notify the City and make this material/equipment available to its representative for inspection.





**SANITARY SEWER SPECIFICATIONS**

**I. GENERAL AND ADMINISTRATIVE**

- A. Scope
  - 1. These specifications shall govern the handling, installation, distribution and testing of sanitary sewer infrastructure including gravity sewer, force mains, manholes, valves, lift stations, and accessories described herein, and as shown on the accompanying plans and details.
  - 2. This work shall consist of installing linear sanitary sewer infrastructure (i.e., gravity sewer and force mains) as well as the construction of lift stations, valves, and related accessories for completing necessary service connections.
- B. Work Included
  - 1. All labor, equipment and material necessary to complete the work stipulated herein. The Contractor shall remove so much of the pavement as may be necessary; excavate the trenches and pits to the required dimensions; excavate the bell holes; construct and maintain all bridges required for traffic control; sheet, brace and support the adjoining ground or structures where necessary; handle all drainage or ground water; guard the site; unload, haul, distribute, lay and test the pipe, fittings, valves, hydrants, lift stations, and accessories; rearrange the branch connections to main sewers, or rearrange other conduits, ducts or pipes where necessary; replace all damaged drains, sewers, or other structures; backfill and compact the trench pits; restore the roadway surface; remove surplus excavated material, and clean the site of the work.
- C. Inspection of Work
  - 1. The Owner/Developer/Contractor shall make available to the City reasonable inspection opportunities. The City also requires all work to be inspected by a qualified representative of the Design Engineer to ensure that the work complies with the City's specifications and the plans as submitted to the City.
- D. Regulatory Requirements
  - 1. In addition to the specifications, all current requirements of the applicable regulatory agencies shall be satisfied. This shall include, but is not limited to the Environmental Protection Agency (EPA) and Alabama Department of Environmental Management (ADEM).
- E. Traffic Control
  - 1. Prior to any work requiring traffic control, a traffic control plan prepared in accordance with the latest revision of the MUTCD shall be submitted to the City for approval. It shall be the Contractor's sole responsibility to maintain adequate traffic







control, to provide detours around construction activities, and to hold the City harmless from claims arising therefrom. Unless approved by the City in writing, no street shall remain closed to traffic over night. In addition, the Contractor shall cooperate with local residents in gaining access to their homes during working hours and shall assist at all times when vehicles experience trouble due to construction activities.

F. Amendments

1. These specifications may be amended from time to time by the City when the City determines appropriate. It shall be the contractor's responsibility to obtain the latest amendments and/or updates from the City.

G. Easements/Rights-of-Way

1. Sanitary sewer mains, services and appurtenances which are to be owned and/or maintained by the City shall be within an easement dedicated to the City or right-of-way.
2. Easements and/or rights-of-way
  - a. For sanitary sewer mains, easements and/or rights-of-way shall be at least 20 feet wide and be at least 10 feet on each side of the main. If the depth of the main is more than 10 feet, the easement width shall be twice the depth from the ground surface to the bottom of the main rounded up to the nearest 5 foot increment, and the easement shall be centered upon said main.
  - b. Where public sanitary sewer pipes are installed within easements crossing private property, the City shall have the right to enter upon the easement for purposes of inspecting, repairing, or replacing the sewer pipes and appurtenances. Where paved private streets, driveways, parking lots, etc. have been installed over public sewer pipes, the City shall not be responsible for the repair or replacement of pavement, curbing, landscaping, etc. which must be removed to facilitate inspection, repairs and/or replacement. The City shall only be responsible for backfill of excavated areas to approximately the original grade. Replacement of privately owned pavement, curbing, walkways, etc. shall be the responsibility of the property owner.
  - c. Sewer mains shall be centered in the easement.
  - d. All off-site easements shall be acquired by the Developer. These off-site easements shall be recorded by deed of easement prior to construction approval. These easements shall be dedicated to the City and labeled "The City of Phenix City Sanitary Sewer Easement".

H. Abbreviations

1. AASHTO: American Association of State Highway and Transportation Officials
2. ADEM: Alabama Department of Environmental Management
3. AWWA: American Water Works Association



**PHENIX CITY**  
*Alabama*

**UTILITIES DEPARTMENT**

Physical Address: 1119 Broad Street  
Phenix City, AL 36867

Mailing Address: P.O. Box 760  
Phenix City, AL 36868

Ph: 334-448-2880

Fx: 334-291-4742

phenixcityal.us

4. ANSI: American National Standards Institute
5. ASTM: American Society for Testing and Materials
6. EPA: United States Environmental Protection Agency
7. NFPA: National Fire Protection Association
8. NSF: National Sanitation Foundation

II. **CONTRACTOR/DEVELOPER RESPONSIBILITY** – The Contractor and Developer are responsible for ensuring that the construction meets these specifications. Any part of the construction which does not meet these specifications shall be repaired or replaced to meet these specifications at no cost to the City of Phenix City.

III. **CONTRACTOR RESPONSIBILITY**

A. Installation and Safety

1. The Contractor shall be responsible for installation of the sanitary sewer system in accordance with the approved construction drawings, notifying the Project Engineer of any discrepancies noted in actual field conditions.
2. Any changes or alterations to the approved design that are requested by the Contractor shall be reviewed and approved by the Project Engineer and the City of Phenix City prior to work beginning in the area of the requested change.
3. Any sanitary sewer installation that is not in accordance with the approved construction drawings shall be removed and installed properly according to the approved construction drawings prior to acceptance by the City of Phenix City.
4. The contractor shall obtain written approval from the Phenix City Utilities Department prior to making any connection to the Phenix City Utilities Department's sanitary sewer system. All connections to the system must be coordinated and performed in the presence of a City inspector or representative of the Phenix City Utilities Department. The written approval shall be presented to the inspector or representative of the Phenix City Utilities Department at the time the connection is made.
5. Barricades, flashers, signs, and other protective devices shall be used when needed to adequately provide for public safety. Such devices shall be supplied, installed and maintained by the Contractor. The Contractor will be solely responsible for safety.

B. Certifications

1. All pipe, fittings, valves and other materials shall be new and unused when delivered to the work site and shall be suitable for installation and operation under the conditions for which they are to be used. All pipes and all fitting shall be suitably marked at their places of manufacturer to show their class or strength. Any pipe or other materials, which have been broken, cracked or otherwise damaged before or





**PHENIX CITY**  
*Alabama*

**UTILITIES DEPARTMENT**

Physical Address: 1119 Broad Street  
Phenix City, AL 36867

Mailing Address: P.O. Box 760  
Phenix City, AL 36868

Ph: 334-448-2880

Fx: 334-291-4742

phenixcityal.us

- after delivery to the work site, or which have failed to meet the required tests, shall be removed from the work site and shall not be used in the work.
2. Detailed construction drawings for pipe in vaults/manholes for air release valves, vacuum release valves, lift stations, etc., shall be submitted to the Phenix City Utilities Department for review before such materials are fabricated and delivered to the work site.
  3. The manufacturer of ductile iron pipe, fittings, and gate and butterfly valves shall furnish the Phenix City Utilities Department, when requested, certification that these materials comply with the appropriate ANSI/AWWA Standard and that compliance has been verified by specified tests and inspection.
  4. Other types of pipe, fittings, and valves shall be inspected and accepted under these specifications by an approved commercial testing laboratory prior to delivery to the work site. Each piece of pipe, fitting, etc., shall be stamped with the laboratory's mark of acceptance and inspection reports shall be furnished to the Phenix City Utilities Department when requested.
- C. Testing
1. The Contractor is responsible for testing all aspects of the sanitary sewer system as outlined in this document in conjunction with the City of Phenix City. All testing requirements shall be arranged and paid by the contractor. The testing laboratory shall be approved by the City. Results from all required testing shall be provided to the City for review.
- D. Site Restoration
1. The Contractor shall clean up and legally dispose of all excess material, trash, wood forms, and other debris. Previously sodded areas that are excavated shall be reestablished with sod of the same type and species as the surrounding grass.
  2. In unimproved areas or areas which do not appear to have been sodded, the disturbed ground shall be seeded with approved Alabama Department of Transportation Mix for permanent grassing, unless specified otherwise.
  3. After completing each section of the sewer line, the Contractor shall remove all debris, construction materials, and equipment from the work site, grade and smooth over the surface on both sides of the line, and leave the entire right-of-way or easement in a clean, neat, and serviceable condition.
  4. All permanent easements shall be graded and smoothed to allow sufficient access and use for mowing equipment and maintenance vehicles prior to acceptance by the City. The permanent easement shall be completely cleared of all trees, brush, boulders, and debris. All rocks shall be buried, crushed, or removed from the easement where, in the opinion of the City, they present a hazard for access and use of the easement. Typically, no rock shall remain on the ground surface that is larger than a No. 1 stone classification.





**PHENIX CITY**  
*Alabama*

**UTILITIES DEPARTMENT**

Physical Address: 1119 Broad Street  
Phenix City, AL 36867

Mailing Address: P.O. Box 760  
Phenix City, AL 36868

Ph: 334-448-2880

Fx: 334-291-4742

phenixcityal.us

5. All creek and ditch crossings shall be located completely within the permanent easement and shall also be made accessible for mowing and maintenance equipment as deemed appropriate by the Phenix City Utilities Department.
  6. When the sanitary main is not installed along a road, the contractor shall install an access drive along the path of the new sanitary sewer main and within the sanitary sewer and/or utility easement which is easily navigable with a standard truck and which will support a full sized, steel track mounted excavator without disturbing the ground or damaging the sanitary main.
- IV. EXCAVATION AND BACKFILLING** – The Contractor shall excavate all substances encountered to the depth shown on the construction drawings. Excavated materials not required and/or not suitable for fill or backfill shall be disposed of by the Contractor in a manner acceptable to the Project Engineer or Project Manager.
- A. General Excavation Requirements**
1. Utility Location
    - a. Contractor shall call Alabama 811 service (811 or 1-800-292-8525) and the Phenix City Utilities Dispatch (334-448-2902) not less than three (3) working days before performing work.
    - b. Request underground utilities to be located and marked within and surrounding construction areas.
    - c. If after two (2) working days, all utility companies have not located their buried lines, call Alabama 811 and/or Phenix City Utilities Dispatch and inform them which utilities have not marked their lines.
  2. Excavations for manholes shall have a minimum of twelve inches (12") clearance on all sides of the manhole.
  3. Excess excavation below the required level shall be backfilled with an approved crushed stone, and thoroughly tamped.
  4. Unsuitable soil shall be removed and replaced with approved crushed stone or other approved material, and shall be thoroughly tamped.
  5. The ground surface adjacent to all excavations shall be graded to prevent water from running into the excavation. The Contractor shall remove any water accumulated in the excavation and keep the trench dewatered until the bedding is complete.
  6. The trench shall be excavated so that the pipe will be laid in the center of the trench in its designed location. The trench width shall be a minimum of twelve inches (12") wider than the pipe bell diameter, and a maximum of twenty-four inches (24") wider than the pipe bell diameter. The bottom of trench for sewers shall be rounded so that an arc of the circumference equal to six-tenths of the outside diameter of the pipe rests on undisturbed soil. Bell holes shall be excavated



**PHENIX CITY**  
*Alabama*

**UTILITIES DEPARTMENT**

Physical Address: 1119 Broad Street  
Phenix City, AL 36867

Mailing Address: P.O. Box 760  
Phenix City, AL 36868

Ph: 334-448-2880

Fx: 334-291-4742

phenixcityal.us

- accurately to size by hand.
7. The Contractor shall provide, install and maintain all bracing, sheeting, and shoring necessary to perform and protect all excavations as required for safety and to conform to all governing laws.
- B. Rock Excavation
1. Rock shall be defined as any material, which occurs in its original position in ledges or bedded deposits of such hardness or texture that cannot be reasonably excavated, loosened, broken, or removed without the use of drilling and blasting methods utilizing a Caterpillar 320, Kobelco 200, Komatsu 220, or comparable trench excavation equipment having a SAE rated net power of at least one hundred and forty-eight horsepower (148 hp) and bucket force of at least thirty-one thousand pounds (31,000 lbs). Concrete and masonry structures that require drilling and blasting for removal and boulders having volumes greater than eight (8) cubic feet shall also be considered rock.
  2. In general, removal of rock will be considered as unclassified excavation and no specific payment will be made therefore except when a bid item is provided in the Bid Schedule for Rock Excavation. When payment is to be made on a unit price basis for removing rock, the rock shall be completely stripped of all overburden over the entire area, if for a structure, and over a length of at least fifty feet (50') if for a pipeline. The Project Engineer will then make the necessary measurements and take elevations on the rock to determine the volume of rock to be removed.
  3. In no case will pavements, manholes, and similar structures be classified as rock, nor will specific payment be made for drilling and blasting materials that can be removed by other methods.
  4. Excavations shall be carried six inches (6") below bottom of pipe and bedding material shall be one-fourth of an inch ( $\frac{1}{4}$ ") to one and one-half inches ( $1\frac{1}{2}$ ") graded crushed stone such as: 56, 57, 6, 67, 68, 7, or 78 stone per ALDOT standard specifications.
  5. In trenches for pipelines, rock shall be removed for the overall width of the trench as specified and to a depth of six inches (6") below the bottom of the pipe for pipes smaller than twenty four inches (24") in diameter. For pipes greater than twenty four inches (24") in diameter, rock shall be removed to a depth of twelve inches (12") below the bottom of the pipe. If concrete cradles are to be constructed, rock shall be removed to allow the cradle to be constructed to the depth shown on the construction drawings.
  6. All storage places for explosives and inflammable materials shall be clearly marked. The method of storing and handling such materials shall conform to all Federal, State, and local laws.
  7. Drilling and blasting methods used in rock excavation shall be optional with the



**PHENIX CITY**  
*Alabama*

**UTILITIES DEPARTMENT**

Physical Address: 1119 Broad Street  
Phenix City, AL 36867

Mailing Address: P.O. Box 760  
Phenix City, AL 36868

Ph: 334-448-2880

Fx: 334-291-4742

phenixcityal.us

- Contractor but shall be conducted with due regard to the safety of persons and property in the vicinity of the work and in strict conformity with all laws, ordinances or regulations governing blasting and the use of explosives.
8. Rock excavation near existing structures of all types shall be conducted with the utmost care, and every precaution shall be taken to prevent damage to such structures. Damage or injury of any nature to persons or property, caused directly or indirectly by blasting operations, shall be promptly repaired, replaced or compensated for by the Contractor at the Contractor's sole expense and to the entire satisfaction of the persons injured or the owners of the property damaged.
- C. Backfilling
1. After pipes have been visually checked for defects, backfilling shall be done with approved material free from large clods or stones, sticks, logs, stumps, or other unsuitable materials.
  2. Backfill material shall be placed evenly and carefully around and over pipe in six inch (6") maximum layers and mechanically compacted. Each layer shall be carefully placed until one foot (1') of cover exists over the pipe. The remainder of backfill materials shall be placed in twelve inch (12") layers and mechanically compacted, unless approved otherwise by the Project Engineer or Geotechnical Engineer.
  3. Fill with voids may be placed up to the top of the pipe and no higher.
  4. At manholes and other structures, all forms, trash, and debris shall be removed and cleared away. Backfill material shall be placed symmetrically on all sides in twelve inch (12") maximum layers. Each layer shall be moistened and compacted with mechanical tampers.
  5. Trenches cut across or along pavement/roadways shall be backfilled and compacted as required by the Phenix City Subdivision Regulations. Temporary asphalt patches shall be placed in accordance with the current City of Phenix City Standard Specifications and Details.
  6. For pipe in fill sections or projecting into fill sections, where pipe is not structurally supported, unsuitable material shall be removed. A foundation shall be constructed using approved foundation material per the Geotechnical Engineer or Project Engineer and a pipe bed shall be constructed using approved bedding material. Subsequently, embedment material shall be placed symmetrically on each side of pipe to a point one foot (1') above the pipe in six inch (6") maximum layers and compacted.
  7. The Contractor shall be responsible for repairing all settled backfilled areas.
  8. Testing compaction of backfill under roadways shall be done in accordance with the testing requirements for street construction of the Phenix City Engineering Department. The developer and/or contractor shall submit the compaction test results to the Phenix City Engineering Department as soon as the results are





available.

**V. MATERIALS**

**A. General**

1. All sanitary sewer pipe materials shall be in accordance with the standards outlined in this section unless otherwise approved by the City of Phenix City.
2. All pipe and fittings shall be installed in accordance with the sizes, materials, slopes, locations, and elevations as shown on the approved construction drawings.
3. Any exceptions to these specifications will be noted on the construction drawings and/or in the Special Conditions if applicable and must be approved by the Phenix City Utilities Department prior to installation.
4. Any changes in the approved design shall receive written approval by the Project Engineer and the City of Phenix City before they are implemented.

**B. Pipes and Fittings**

1. Ductile Iron (DI) Pipe and Fittings – A.S.T.M., A.N.S.I. A746, A-21.11, latest revision. All ductile-iron pipe and fittings shall be cement mortar lined, and shop painted inside and out, with one coat of bituminous coating at least 1 mil thick.
2. Polyvinyl Chloride (PVC) Pipe and Fittings – A.S.T.M. D-3034, and A.S.T.M. D-3212, latest revision.
3. High Density Polyethylene (HDPE) Pipe and Fittings – A.S.T.M. D-3035, PE 3408, A.S.T.M. F714, A.S.T.M. D-3261 and A.S.T.M. D-3350, Latest Revision.

**C. Joints**

1. Ductile Iron Pipe – Rubber gasket joints A.S.A. 21.11, latest revision.
2. Polyvinyl Chloride (PVC) Pipe – Flexible elastomeric seals A.S.T.M. D-3212, latest revision.
3. High Density Polyethylene (HDPE) Pipe – Butt Heat Fusion A.S.T.M. D-3261, Latest Revision

**D. Classes**

1. Ductile Iron Pipe – Pressure Class 350 or Thickness Class 51, unless otherwise approved.
2. Polyvinyl Chloride (PVC) Pipe – Gravity Sewers; SDR 35 or stronger.
3. High Density Polyethylene (HDPE) Pipe – PE 4710 SDR 11 unless otherwise approved.

**VI. CONSTRUCTION METHODS**

**A. General**

1. Manufacturer's information should be consulted for proper installation procedures for the various types and sizes of pipe.
2. All sewers shall be laid true to line and grade with bells in the direction that the



**PHENIX CITY**  
*Alabama*

**UTILITIES DEPARTMENT**

Physical Address: 1119 Broad Street  
Phenix City, AL 36867

Mailing Address: P.O. Box 760  
Phenix City, AL 36868

Ph: 334-448-2880

Fx: 334-291-4742

phenixcityal.us

- pipe is laid and shall be laid from the lowest point to the highest unless approved otherwise by the Phenix City Utilities Department.
3. The sections of the pipe shall be so laid and fitted together that, when complete, the sewer will have a smooth and uniform invert.
  4. Pipe and accessories shall be handled in such a manner as will insure delivery to its final position on the work in an undamaged condition. Pipe coating and lining shall be carefully protected.
  5. The pipe shall be kept thoroughly clean so that jointing compounds will adhere. The inside of each section shall be thoroughly cleaned just before it is placed in final position, and shall be kept clean and free of water during laying operations.
  6. Water shall not be allowed in the trenches while the pipes are being laid. Water shall not be allowed to rise around the joint until it has set.
  7. The excavation of trenches shall be fully completed a sufficient distance in advance of the laying of the sewer, and the exposed end of all pipes shall be fully protected with a board or other approved stopper to prevent earth or other substances from entering the pipe.
  8. The interior of the sewer shall be carefully freed from all dirt, cement, or superfluous material of every description as the work progresses. Pipes shall be thoroughly flushed at the completion of laying and jointing prior to inspection. All water used in flushing will not be allowed to enter sewer connected to the City system.
  9. Where creek crossings are encountered, any pipe which has less than thirty inches (30") of cover shall be ductile-iron, and shall be mechanical joint or locking gaskets and be encased in concrete. In either case, at least two (2) restrained joints of pipe are required inside each creek bank. In cases where the pipe will be exposed, concrete piers shall be constructed at the bell side of each joint and ductile-iron pipe shall be used.
  10. If PVC or HDPE pipe is used, embedment material must be used as shown on the standard details.
  11. Gravity sewer mains shall be designed and installed below finished grade with a depth of cover between three feet (3') and eight feet (8') unless otherwise approved by the Phenix City Utilities Department. If the actual depth of cover varies from the planned depths shown on the approved construction drawings, the Contractor shall notify the Project Engineer and the City Inspector of the discrepancy prior to proceeding with construction in that area.
  12. PVC pipe may be used when the depth of cover is greater than three feet (3') and less than twelve feet (12'). Ductile iron pipe shall be used when the depth of cover is three feet (3') or less and twelve feet (12') or more.
  13. Pipe shall have smooth ends. If pipe is cut, the cuts shall be straight and smooth





**PHENIX CITY**  
*Alabama*

**UTILITIES DEPARTMENT**

Physical Address: 1119 Broad Street  
Phenix City, AL 36867

Mailing Address: P.O. Box 760  
Phenix City, AL 36868

Ph: 334-448-2880

Fx: 334-291-4742

phenixcityal.us

with no rough edges.

14. Pipe shall have no damage. This includes pipe material and pipe liners and coatings.

**B. Bore Installation**

1. Where borings are required, they shall be a traditional jack-and-bore construction method using a steel casing. Directional drilling methods shall not be allowed for the installation of sewer mains and services.
2. Steel encasement pipe shall be welded or seamless, consisting of grade "B" steel with minimum yield strength of 35,000 psi and manufactured in accordance with ASTM A139.
3. All bores for sewer mains and services shall be placed on proper grade and delivered precisely to the location shown on the construction drawings with uniform slope and direction.
4. Where bore installations are required, the carrier pipe shall be ductile iron unless otherwise approved by the Phenix City Utilities Department, and the pipe joints shall be restrained using external restraint mechanisms or locking gasket restraints.
5. The carrier pipe shall be encased in welded steel pipe, having a minimum wall thickness of one-fourth of an inch (1/4") in accordance with Table A.
6. Casing spacers shall be used to convey the carrier pipe through the encasement and keep the carrier pipe centered in the casing.
7. The casing spacers shall be Cascade CCS models or approved equal.
8. The casing shall be sealed at each end with rubber boot and double band stainless steel straps to prevent any water or other materials from entering the encasement.
9. The casing seal shall be Cascade CCES model or approved equal.
10. Where possible, the steel casing shall extend at least five feet (5') beyond the edge of the roadway or planned roadway widening, but shall in no case continue within five feet (5') of a service connection or cleanout.
11. Where sewer service connections are being made, the existing sewer main shall be excavated as part of the receiving pit, prior to setting up the bore, to verify the necessary depth and grade shown on the construction drawings.
12. All other utilities shall be located and potholed, where necessary, prior to performing the bore.
13. Table A outlines the minimum casing sizes based on the carrier pipe size:



Table A

Carrier Pipe		Steel Casing		
Nominal Pipe Diameter	Standard Pipe Bell O.D.*	Casing Spacer Band Width	Minimum Casing Thickness	Minimum Casing Inside Diameter**
4	6.4	8	0.25	14
6	8.6	8	0.25	16
8	11.16	8	0.25	18
10	13.25	8	0.25	20
12	15.22	8	0.25	22
14	17.73	12	0.25	24
16	19.86	12	0.3125	26
18	22.16	12	0.3125	30
20	24.28	12	0.3125	32
24	28.5	12	0.3125	36
30	35.4	12	0.5	42
36	41.84	12	0.5	48

All sizes are indicated in inches.

\*Pipe bell outside diameter based on Pressure Class 350 ductile iron pipe.

\*\*Casing inside diameters are based on being a minimum of 6 inches greater than the outer diameter of the joint bell, to the nearest even inch.

C. Sewer Laterals and Stub Outs

1. Lateral connections are to be made into manholes or into the top quarter of sewer mains, avoiding angles that go against the flow of the main.
2. The minimum diameter of a sewer lateral or stub out shall be four inches (4"). Sewer laterals or stub outs with a diameter of six inches (6") or greater shall connect directly to manholes. A manhole may need to be installed for the sewer lateral or stub out.
3. Clean-outs for sewer services shall be located at intervals no greater than 50 feet for 4-inch pipe and 100 feet for 6-inch pipe.
4. All single family residences, multi-family residences up to 4 dwelling units on the same property and businesses shall have individual connections for each dwelling unit and business unit to public sewer main.
5. All connections, such as sewer stub outs, which are for future use, shall be properly capped.
6. No pipe shall be cut for connections except when permitted by the City of Phenix City.



**PHENIX CITY**  
*Alabama*

**UTILITIES DEPARTMENT**

Physical Address: 1119 Broad Street  
Phenix City, AL 36867

Mailing Address: P.O. Box 760  
Phenix City, AL 36868

Ph: 334-448-2880

Fx: 334-291-4742

phenixcityal.us

7. All sanitary sewer lateral and stub out locations shall be identified by green Dura Stripe paint or approved equal on the concrete gutter and on the face of the curb where streets are being built.
8. The contractor shall mark the termination point of the lateral above grade using a green post or marker which is at least 3 feet above grade. A cleanout may be used for the marker.
9. Sewer laterals shall be installed per the approved construction drawings and shall typically be installed directly from a sewer manhole or main perpendicular to the ROW, easement, or property line.
10. Sewer laterals shall be located in areas free from obstructions in maintaining continuous grade and alignment.
11. Where a lateral is to be connected to an existing manhole where the existing main is larger than twelve inches (12") in diameter, the invert of the connection shall be made above the crown of the existing main.
12. Where a lateral is to be connected to an existing manhole where the existing main is twelve inches (12") in diameter or smaller, the invert of the lateral connection shall be at least one (1) foot above the manhole invert.
13. Laterals entering beginning manholes shall be directed into the flow line by a grouted invert with no drop allowed.
14. Where sewer laterals must be connected directly to a sewer main, the connections shall be separated by a minimum of three feet (3').
15. For new sewer main installation, the contractor shall install an inline "tee" or "wye" in all locations where a lateral is proposed to connect directly to the main.
16. Under no circumstances shall any lateral connection be allowed to protrude into the sewer main.
17. At least one (1) cleanout shall be installed on all sewer laterals at the edge of the right-of-way or easement.
18. A manhole shall be installed in lieu of a cleanout on all industrial/commercial service lines greater than or equal to 8 inches in diameter.
19. When a property will be served with Phenix City sanitary sewer and not Phenix City water, a sanitary disconnect valve shall be installed on the sanitary service within the public right-of-way or sanitary easement. The valve shall be Spears Sewer Disconnect valve or approved equal.
20. Laterals and stubouts shall be free of defects including but not limited to cracks, holes, pits, rough or jagged cuts, and deformation.
21. Back flow preventers shall be required on sanitary sewer services for buildings which lowest finish floor elevation is either less than one foot above the cover of the nearest up stream manhole if the service is connected to a sanitary main, or less than one foot above the manhole cover if the service is connected directly to a





**PHENIX CITY**  
*Alabama*

**UTILITIES DEPARTMENT**

Physical Address: 1119 Broad Street  
Phenix City, AL 36867

Mailing Address: P.O. Box 760  
Phenix City, AL 36868

Ph: 334-448-2880

Fx: 334-291-4742

phenixcityal.us

- manhole.
22. New services shall have a minimum horizontal clearance of five (5) feet from any paved driveway and/or sidewalk.
  23. Driveways placed near existing services shall have a minimum horizontal clearance of five (5) feet from any existing service.
- D. Separation from Water Lines
1. Except where a sewer line is crossing a water line, all sanitary sewer lines and/or structures shall be laid at least ten feet (10') horizontally, measured edge to edge, from any existing or proposed water main, unless otherwise approved by the Phenix City Utilities Department, and in no case shall a sanitary sewer line and/or structure be placed less than five feet (5') horizontally from a water line. (ADEM Admin. Code r. 335-7-7-.03a)
  2. Where ten feet (10') horizontal separation cannot be attained,
    - a. Sanitary sewer line must be ductile iron, and
    - b. Sanitary sewer line shall be hydrostatically pressure tested to one hundred and fifty pounds per square inch (150 psi).
  3. Where it is necessary for a sanitary sewer line to cross a water line,
    - a. The water and sanitary sewer lines shall cross as close to 90° as possible and no less than 75°.
    - b. The top elevation of the sanitary sewer line shall be a minimum of 18 inches below the elevation of the bottom of the water line. (ADEM Admin. Code r. 335-7-7-.03a)
    - c. The crossing shall be arranged so that the sections of pipe will be centered on the crossing providing maximum separation of the joints.
    - d. For mains, place a continuous casing around one of the mains to allow a minimum 10 foot separation between each end of the cased and uncased main.
- E. Separation from Storm Lines
1. If a sanitary main shall be lower than a storm sewer main or structure, the sanitary main shall be separated from storm sewer mains and structures by a minimum of ten feet (10') horizontally and 12 inches (12") vertically unless otherwise approved by the Phenix City Utilities Department.
  2. If a sanitary main shall higher than a storm sewer main or structure, the sanitary main shall be separated from storm sewer mains and structures by a minimum of thirty-six inches (36") horizontally and 12 inches (12") vertically unless otherwise approved by the Phenix City Utilities Department.
  3. In no case shall a sanitary main be allowed inside a storm sewer main or structure.



**PHENIX CITY**  
*Alabama*

**UTILITIES DEPARTMENT**

Physical Address: 1119 Broad Street  
Phenix City, AL 36867

Mailing Address: P.O. Box 760  
Phenix City, AL 36868

Ph: 334-448-2880

Fx: 334-291-4742

phenixcityal.us

- F. Separation from other utilities, structures, et cetera
1. If a sanitary main shall be lower than a pipe or structure other than water or storm, the sanitary main shall be separated from pipes and/or structures by a minimum of five feet (5') horizontally and 12 inches (12") vertically unless otherwise approved by the Phenix City Utilities Department.
  2. If a sanitary main shall higher than a storm sewer main or structure, the sanitary main shall be separated from pipes and/or structures by a minimum of thirty-six inches (36") horizontally and 12 inches (12") vertically unless otherwise approved by the Phenix City Utilities Department.
  3. In no case shall a sanitary main be allowed inside another pipe or structure except for the sanitary main's own casing.

### VII. MANHOLES

- A. Manholes shall be constructed of pre-cast structural concrete (except for dog house manhole base slabs) with cast iron frames and covers as shown on the City of Phenix City's Standard Details.
- B. Sewer manholes shall be cylindrical in shape. Manholes that are box shaped shall not be allowed.
- C. Manholes shall have a concentric cone section on top in road rights-of-way and flat top sections with ring and cover flush with top in areas outside of road rights-of-way unless otherwise approved by the Phenix City Utilities Department.
- D. Manholes located in cul-de-sacs shall be 5-foot diameter.
- E. The minimum depth of a sewer manhole is fifty (50) inches providing adequate space for a standard precast concentric base cone section, ring, and cover, unless otherwise approved by the Phenix City Utilities Department.
- F. In all cases, clear line of sight shall be maintained from the manhole rim to all pipe inverts.
- G. Manholes shall be spaced a maximum distance of 400 feet apart.
- H. All new manholes shall have a maximum chimney height of 8 inches, including mortar joints. The total thickness of grade rings shall not exceed 6 inches. All frames shall be sealed to the manhole.
- I. Precast concrete manhole base slabs shall be bonded to the walls.
- J. Manholes shall be precast concrete and rubber boots/flexible connectors shall be used for all pipe connections to the manhole.
- K. Manholes shall be constructed only when temperature is above forty degrees Fahrenheit (40°F). All work shall be protected against freezing.
- L. New manholes shall be free of defects including but not limited to cracks, holes, pits, and exposed reinforcement.
- M. Drop manholes shall be constructed when the invert of the incoming pipe is twenty



**PHENIX CITY**  
*Alabama*

**UTILITIES DEPARTMENT**

Physical Address: 1119 Broad Street  
Phenix City, AL 36867

Mailing Address: P.O. Box 760  
Phenix City, AL 36868

Ph: 334-448-2880

Fx: 334-291-4742

phenixcityal.us

- four inches (24") or more, higher than the invert of the outgoing pipe. Drops shall be inside manholes unless otherwise approved by the Phenix City Utilities Department. The minimum inside diameter for a drop manhole is five (5) feet.
- N. Invert channels shall be smooth, accurately shaped, and in accordance with the City of Phenix City's Standard Details. Invert may be formed directly in the concrete of the manhole base or be constructed by laying full section sewer pipe straight through the manhole and cutting out the top half after the concrete base is constructed and sufficiently set.
  - O. Connections in manholes shall be done in a manner to provide as little turbulence and disruption to the flow as possible. All connections shall be directed into the flow smoothly by shaping the invert or apron to accommodate all incoming sewer lines. The invert shall be formed and poured to provide a smooth transition across the manhole.
  - P. Manhole connections shall be sealed appropriately to minimize ground water infiltration into the sewer system.
  - Q. All connections into manholes shall have a minimum spacing of six inches (6") from the outsides of the pipes, or not less than the diameter of the largest incoming pipe, whichever is greater.
  - R. Manholes shall be installed at each deflection of line and/or grade.
  - S. Minimum drop in straight through manholes, less than or equal to twenty two degrees (22°) deflection, shall be no less than one-tenth of a foot (0.10').
  - T. Minimum drop in turning manholes, greater than twenty two degrees (22°) deflection, shall be no less than one-fourth of a foot (0.25').
  - U. No turning manholes greater than ninety degrees (90°) will be permitted unless approved by the Phenix City Utilities Department on a case specific basis.
  - V. Polypropylene plastic steps with steel reinforcement shall be installed as shown on the City of Phenix City's Standard Details. Cast-iron shall conform to A.S.T.M. A-48 and AASHTO M-306 and wrought iron shall conform to A.S.T.M. A-41 and AASHTO M-306. Steps shall be wide enough for a worker to place both feet on each one step, and shall be designed lateral slipping off step. Cast or anchor steps into manhole wall at 12 inch to 16 inch intervals.
  - W. Frames and covers shall be of the type and duty shown on the City of Phenix City Standard Details. The cover slot shall be twenty six inches (26") in diameter allowing a cover diameter of twenty five and three fourth inches (25-3/4") with one eighth inch (1/8") annular space on all sides.
  - X. The minimum cover weight shall be 190 lbs.
  - Y. Manhole covers shall have two non-penetrating pick holes.
  - Z. Standard frames and covers shall be U.S. Foundry USF-227 ring and AS cover which reads "Phenix City Alabama Sanitary" or approved equal.
  - AA. Watertight frame and cover shall be U.S. Foundry USF-152-BV-BWT ring and cover





which has a water tight gasket, bolts or a cam lock, and reads "Phenix City Alabama Sanitary" or approved equal.

- BB. Iron castings shall conform to A.S.T.M. A-48, Class 20 and AASHTO M-306. All castings shall be true to pattern in form and dimensions, free from faults, sponginess, cracks, blowholes, and other defects affecting their strength. Bearing surface between cast frames, covers, and grates shall be machine fitted together and match-marked to prevent rocking.
- CC. All manholes located within the 100-year flood plain shall have a concrete waterproofing admixture of the cementitious crystalline type, such as Xypex admix C-500R or approved equal, added according to the product manufacturer's specifications.
- DD. The tops of manhole covers shall be flush with the finished grade in paved areas or grassed lawns which are frequently mowed to keep grass from growing over manhole cover. The tops of of manhole covers in other areas shall be at least one foot (1') above finished grade and a maximum of four feet (4') above finished grade.
- EE. Manhole lids located within one vertical foot (1') of the 100-year floodplain elevation shall be water-tight gasketed with lock-down lid, and anchor ring. Where the finished grade elevation at the manhole is 3 feet or less below the 100-year floodplain elevation, risers shall be utilized to extend the rim elevation to one foot (1') above the 100-year floodplain elevation. Manholes shall be located a minimum of fifteen feet (15') from any stream bank or water body.
- FF. Manhole adjusting rings shall be Neenah Foundry R-1979 Series, EJCO M Series, or approved equal, and shall be one piece construction with no welds and coated to prevent rust. Multiple risers may be used and must be welded together.
- GG. Manhole section joints should be sealed with prefabricated rubber gaskets or formed in place tongue and groove butyl or mastic sealant.
- HH. Manholes and mains shall be no closer to other pipes or structures than they are deep.

**VIII. GREASE INTERCEPTORS AND TRAPS**

- A. General Requirements
  - 1. Grease Control Equipment (GCE) shall be designed and constructed in accordance with the provisions of these specifications, the City of Phenix City's Sewer Use Regulations and the City of Phenix City's Standards and Specifications.
  - 2. Grease interceptors shall be constructed of pre-cast structural concrete with cast-iron frames and covers as shown on the City of Phenix City's Standard Details.
  - 3. Grease interceptors shall include a baffled chamber design with a maximum opening through the baffle separating the chambers of twelve inches (12") high by the width of the tank. Two tanks without baffles, placed in series may be used also.
  - 4. Grease interceptors that are installed in series shall be installed in such a manner to



**PHENIX CITY**  
*Alabama*

**UTILITIES DEPARTMENT**

Physical Address: 1119 Broad Street  
Phenix City, AL 36867

Mailing Address: P.O. Box 760  
Phenix City, AL 36868

Ph: 334-448-2880

Fx: 334-291-4742

phenixcityal.us

ensure positive flow between the tanks at all times. Tanks shall be installed so that the inlet invert of each successive tank shall be a minimum of 2-inches below the outlet invert of the preceding tank.

5. Grease interceptors and traps shall be sized based on the current City of Phenix City Sewer Use Regulations and interceptors shall have a minimum volume of one thousand gallons (1000 gal).
6. Grease interceptors shall be required to have a minimum of two access manholes for cleaning and inspection.
7. A sampling port or manhole shall be installed downstream of the grease interceptor. The sampling port shall be a minimum of twelve inches (12") in diameter and shall have a minimum of six inches (6") of fall between the inlet and outlet. No other connections to the sewer line are allowed between the grease interceptor and the sampling manhole.
8. The inlet and outlet pipes of the grease interceptor or trap shall be Schedule 40 PVC or stronger. The open-ended tee used to extend the inlet and outlet below the fluid level shall not be covered or capped.
9. The interceptor inlet pipe must be a minimum of four inches (4") in diameter, and the vertical pipe on the outlet side must be a minimum of six inches (6") in diameter.
10. Vents on grease collection devices/tanks, where applicable, shall be a minimum of two inches (2") in diameter and shall be connected to the buildings vent system.
11. Grease interceptors shall not be located in an entrance, exit, drive-through, or under a menu board, sign, or structure.
12. Manhole rings and covers shall not be covered or obscured by landscaping, pavement, or other obstructions.
13. The manhole cover shall be secured by a bolt or locking mechanism or shall have sufficient weight to prevent unauthorized access.
14. The food service establishment shall insure that a grease trap manhole is secured and locked at all times. *The covers must be removed for inspection of tank.*
15. All new FSE construction and upgrades having a GCE requirement shall be constructed to include a sample monitoring station approved by the City.

**IX. LIFT STATIONS AND FORCE MAINS** – Lift stations shall be constructed in accordance with the approved construction drawings, technical specifications, and all applicable federal, state, and local regulatory codes.

**A. Pumps**

1. Submersible pumps shall be at a minimum vertical, double mechanical sealed, non-clog, solids handling pumps capable of passing a three inch (3") diameter sphere.
2. Submersible grinder pumps are not acceptable.





**PHENIX CITY**  
*Alabama*

**UTILITIES DEPARTMENT**

Physical Address: 1119 Broad Street  
Phenix City, AL 36867

Mailing Address: P.O. Box 760  
Phenix City, AL 36868

Ph: 334-448-2880

Fx: 334-291-4742

phenixcityal.us

3. Pump suction and discharge openings shall be a minimum of four inches (4") in diameter unless otherwise approved by the Phenix City Utilities Department, and each pump shall have an individual intake.
  4. The pump casing and volute shall be constructed of heavy duty cast iron or stainless steel.
  5. The impeller shall be constructed of stainless steel or abrasion resistant cast iron.
  6. The shaft shall be constructed of stainless steel and shall be supported by heavy duty sealed anti-friction bearings.
  7. The bearings shall be sized to handle all expected loads and shall have a minimum rating of fifty thousand hours (50,000 hrs).
  8. The casing and impeller shall be fitted with removable and replaceable wear rings. The elastomer seals shall be constructed of nitrile rubber.
  9. The submersible pumps shall be equipped with a double mechanical seal to prevent leakage into the pump shaft.
  10. The pumps shall be equipped with a moisture detection switch to activate a warning alarm in case of seal failure.
  11. Pumps shall be manufactured by Flygt or an approved equal.
- B. Guide Rails
1. All pump stations shall be equipped with guide rails for extracting the pumps from the wet well.
  2. The sliding guide bracket shall be an integral part of the pump unit.
  3. The pump lifting chain shall be sized to accommodate the installed pump weight, but shall in no case be sized smaller than three sixteenths of an inch (3/16") diameter links.
  4. All guide rails, lifting chains, clevises, shackles, hook assemblies, guide rail brackets, anchors, bolts, nuts, and other exposed metal shall be American Society of Testing and Materials (A.S.T.M.) A276 Type 316 stainless steel.
- C. Lift System
1. All pump stations shall include a pump lift system capable of safely removing all lift station pumps.
  2. At a minimum, the pump lift system shall be a portable hoist with an adjustable reach from twenty four inches (24") to thirty six inches (36").
  3. The winch shall have a minimum load rating of one and one half (1 ½) the weight of the pump or one thousand pounds (1,000 lbs) whichever is greater.
  4. The hoist shall be installed with a socket embedded in a concrete base adjacent to the top of the wet-well.
  5. The hoist shall be at a minimum Halliday Products-Series D2B Portable Hoist with Series D Portable Hoist Socket, or an approved equal.
  6. The hoist shall be provided with a weather-resistant cover.



### D. Isolation Valves

1. All isolation valves installed at sanitary sewer pump stations and on sanitary sewer force mains shall be either resilient-seated gate valves or eccentric plug valves with a minimum port opening equal to one hundred percent (100%) of the adjacent pipe area, thereby providing maximum passage of solids.
2. The valves shall be rated for a minimum one hundred and fifty pounds per square inch (150 psi) working pressure.
3. Each pump discharge shall have an isolation valve installed after the check valve in the valve vault. The valves shall be the same nominal dimension as the discharge piping.
4. Valves installed in a vault shall include a hand wheel operated actuator.
5. Each underground valve shall be provided with a cast iron valve box to house and protect the valve stem. All valve boxes installed in unpaved areas shall have a concrete collar installed. If a precast collar is used, the annular space between the collar and the valve box shall be grouted in. Ductile iron or cast iron pipe shall not be used as valve box extension unless approved by the Phenix City Utilities Department.

### E. Check Valves

1. A check valve shall be installed on each pump discharge including the submersible pumps, the quick connection to the force main for bypass pumping, and if a standby pump is installed, on the standby pump.
2. The check valves shall be swing type with an external arm and counter weight, and shall have flanged ends, a cast iron body, solid bronze hinges, and a stainless steel hinge shaft.
3. Check valves shall be rated to a minimum one hundred and fifty pounds per square inch (150 psi) working pressure and shall be manufactured in compliance with AWWA C508.

### F. Piping – All piping shall be ductile iron, PVC, or stainless steel, and all shall be suitable for use in corrosive wastewater environments.

#### 1. Gravity

- a. The incoming gravity line shall be turned down into the wet well with an open-ended cross and extend to the low water level to minimize turbulence. The open ends of the cross shall be directed towards the top and center of the wet well to allow for maintenance and cleaning of the incoming gravity line and drop pipe.
- b. All ductile iron gravity piping inside the wet well shall be manufactured with a suitable corrosion-resistant liner, Protecto 401 or approved equal and shall be coated on the exterior with a one hundred percent (100%) epoxy coating, suitable for use in corrosive wastewater applications.



**PHENIX CITY**  
*Alabama*

**UTILITIES DEPARTMENT**

Physical Address: 1119 Broad Street  
Phenix City, AL 36867

Mailing Address: P.O. Box 760  
Phenix City, AL 36868

Ph: 334-448-2880

Fx: 334-291-4742

phenixcityal.us

### 2. Force Mains

- a. All force main piping (including piping offsite) shall at a minimum strength rating be PVC SDR 21, Class 200 for working pressure up to 110 psi, ductile iron, class 350 using either mechanical or push-on joints, HDPE 4710 SDR 11 or approved equal.
- b. Flanged ductile iron piping intended for installation in the wet-well shall be coated on the exterior with a one hundred percent (100%) epoxy coating, suitable for use in corrosive wastewater applications.
- c. The Contractor shall install the force main in accordance with the design profile in the approved construction drawings. All force mains shall have a minimum cover of thirty inches (30") and a maximum cover of eight feet (8') where absolutely necessary. The minimum cover at all high points shall be sixty inches (60") to allow for proper air release valve installation.
- d. Permanent thrust restraint should be provided at all bends, tees, plugs, fittings, or other significant changes in direction. Thrust restraint shall typically be provided using externally restrained joints in lieu of thrust restraint concrete blocking unless otherwise approved.
- e. Non-detectable or detectable mesh or tape shall be installed twelve inches (12") above a ductile iron force main. The mesh or tape shall have a warning about the sanitary sewer line below it.
- f. Detectable mesh or tape shall be installed twelve inches (12") above a PVC or HDPE force main. The detectable mesh or tape tracer wire shall stub out of the ground at a minimum every five hundred feet (500') in a valve box and at all air release valve manholes. The detectable mesh or tape shall have a warning about the sanitary sewer line below it.
- g. Force mains shall discharge to a gravity sewer in a manner that smoothly directs the force main flow into the gravity sewer flow. There should not be a turn of greater than ninety degrees (90°) in the terminating manhole.
- h. The terminating manhole shall be lined with a protective coating (SpectraShield, or an approved equal).
- i. Force mains shall be continuously sloped between high and low points.
- j. Force mains shall be clearly marked on the outside of the pipe with green markings or striping prior to installation for identification purposes.
- k. All main line valve boxes shall be painted green and appropriately marked for sewer.
- l. The Contractor shall place a vertical piece of two inch (2") diameter PVC pipe at all bends, fittings, elevation transitions, and at a minimum of every one hundred feet (100') along the force main for the purpose of attaining the vertical elevation of the pipe at the time the "as-built" drawings are surveyed.





The contractor shall also be responsible for removing or abandoning the PVC pipes upon approval of the “as-built” drawings by the Phenix City Utilities Department.

- m. All pump stations shall include four inch (4”) diameter intake and discharge quick-connections for bypass pumping purposes. The quick-connect intake piping shall be extended to the low water level inside the wet well. The quick-connect discharge piping shall connect directly to the force main and shall be equipped with a check valve and an isolation valve.
- 3. Wall Penetrations
  - a. All pipe penetrating the wet well shall be Type 316 stainless steel.
- G. Air Release and Vacuum Valves
  - 1. Air release valves
    - a. Shall be automatic and designed to allow escape of air under pressure and close water-tight when liquid enters the valve.
    - b. Shall have a 1-inch NPT inlet and a maximum orifice diameter of 3/32-inch.
    - c. The valve body shall be designed to facilitate disassembly for cleaning and maintenance.
    - d. The valve body, float, valve seat and all working parts shall be of corrosion-resistant materials.
    - e. Shall be equipped with the necessary attachments, including valves, quick disconnect couplings and hose, to permit back flushing after installation without dismantling the valve.
  - 2. Air/Vacuum Valves
    - a. Shall be automatic air and vacuum valves designed to allow escape of air, close water-tight when liquid enters the valve, and allow air to enter in the event of a vacuum.
    - b. The valve body shall be designed to facilitate disassembly for cleaning and maintenance.
    - c. The valve body, float, valve seat and all working parts shall be of corrosion-resistant materials.
    - d. Valves shall be equipped with the necessary attachments, including valves, quick disconnect couplings and hose, to permit back flushing after installation without dismantling the valve.
    - e. The valves shall have an orifice diameter of 2-inches and NPT inlet and outlet diameters of 2 x 2-inches.
  - 3. Automatic air release valves shall be installed in relatively flat areas of the force main or as indicated on the construction drawings.
  - 4. Combination air/vacuum valves shall be installed at crests or high points of the force main or as indicated on the construction drawings.



5. Air release valves shall be specifically manufactured for wastewater applications. The valve body shall be constructed of Type 316 stainless steel.
  6. Air release valves shall be manufactured by Vent-O-Mat, ARI, Val-Matic or an approved equal.
  7. A hand wheel valve shall be installed above the connection to the force main to isolate the air release valve.
  8. All air release valves shall be placed in a manhole and installed as shown in the standard details. The manhole rim shall be level with the surrounding grade near any traffic area.
  9. Air Release Valves shall be installed on a level section of pipe equidistant between joints.
- H. Electrical - All electrical components of a pump station shall be installed in accordance with National Fire Protection Association (NFPA) Article 820, the Institute of Electrical and Electronics Engineers (IEEE), and the National Electrical Code (NEC), as well as all local electrical codes. The wet well of a sewer pump station is classified as a Class I, Division 1 or 2, Group D hazardous location per NFPA Article 820.
1. Power Supply
    - a. Pump stations shall be served by utility supplied 3-phase power.
    - b. A UL recognized 3-phase power monitor shall interrupt the control power in the event of phase loss, phase reversal, low voltage, and phase unbalance. The power monitor shall have primary fuse protection. The contacts shall be rated for fifteen amps (15A) resistive at one hundred and twenty volts alternating current (120 VAC).
    - c. For most installations, the standard electrical supply shall be four hundred and eighty Volt (480 V), and sixty Hertz (60 HZ).
    - d. All electrical breakers shall be located inside the fenced site.
    - e. The surge protector shall be parallel MOV design and shall provide protection for Category C Transient Surges as defined in ANS/IEEE C62.41 without degradation of components. Protection shall be provided between each phase line and the ground line. The surge protection shall be Stedi-Volt, V-Blox or approved equal.
    - f. The electrical system shall also be protected by a lightning arrester capable of handling up to six hundred volts alternating current (600 VAC).
    - g. A one hundred and ten Volt (110 V), ground fault interrupter (GFI), 2-plug outlet inside a weather enclosure shall be provided and have a dedicated fifteen amp (15 A) circuit breaker. The outlet shall be located at the electrical control panel.
  2. Motors



UTILITIES DEPARTMENT

Physical Address: 1119 Broad Street  
Phenix City, AL 36867

Mailing Address: P.O. Box 760  
Phenix City, AL 36868

Ph: 334-448-2880

Fx: 334-291-4742

phenixcityal.us

- a. All pump stations shall include three-phase, explosion-proof motors, with a maximum speed of one thousand eight hundred revolutions per minute (1,800 RPM).
  - b. Motors shall be high efficiency, utilizing copper winding, Class F or H insulation, and heavy varnish.
  - c. The motor shall be non-overloading for the entire pump curve.
  - d. The motor electrical design shall comply with National Electrical Manufacturers Association (NEMA) Design B.
  - e. The motors shall be equipped with thermal overload protectors embedded in each phase of the windings to sense high temperatures.
  - f. The pump motor shall be housed in an air-filled or oil-filled water tight chamber designed to operate continuously in a nonsubmerged application. The chamber shall be constructed of heavy duty cast iron.
  - g. The cable entry shall be sealed to prevent capillary leakage into the motor chamber. The motor and motor housing shall be bolted to the pump body to allow for removal and repair.
  - h. Motors shall be supplied with a high quality, factory applied epoxy coating system.
3. Control Panel
- a. The pump control panel system shall be fabricated by a current 698A listed industrial control panel manufacturer. The panel manufacturer shall show its UL follow-up service procedure file number on submittals. All devices within the panel shall be UL listed and/or recognized where applicable and shall be mounted and wired in accordance with the most current edition of 698A and NFPA.
  - b. The panel shall be factory assembled, wired, and fully tested prior to shipment. Testing shall include both power and control devices as well as all control functions. A final inspection shall be performed prior to shipment and a copy of this form shall be provided with the panel. The panel manufacturer shall supply two (2) sets of as-wired drawings upon completion of construction to the City of Phenix City.
  - c. An HOA Switch shall be included for each pump and shall provide the following functionality:
    - 1) HAND—In this position, the applicable pump shall run without regard for the level sensing commands and will rely on operator discipline to run and stop.
    - 2) AUTO—In this position, the pumps shall be controlled by the local pump controller in the control panel. The controller will sense the level in the wet well and initiate start and stop commands to the pumps based on







- configured on/off set points.
- 3) OFF—In this position, the applicable pump will not run under any circumstance.
- d. All electrical enclosures shall be NEMA -4X standard lockable control panel on a stainless steel frame with an external operating handle to padlock the breaker in the “ON” or “OFF” positions. The enclosure shall be sized sufficiently to contain the required components and shall be designed specifically for municipal wastewater applications.
- e. All pump controls shall be located inside the lockable control panel.
- f. An equipment data tag shall be permanently affixed on the inside of the exterior door of the control panel with the station designation, power source, pump horsepower, and pump full load amps.
- g. In addition to the label requirements of UL 698A, an engraved legend plate shall be permanently affixed on the inside of the exterior door of the control panel with the name, address, and telephone number of the service representative for the pumps and control panel.
- h. All conduits shall be rigid galvanized (no PVC) and electrical equipment shall be explosion proof for installation inside the wet well.
- i. Electrical penetrations into the wet-well shall be appropriately sealed using explosion-proof seal fittings and approved sealing compound. Fittings shall be Crouse-Hinds or approved equal, and sealing compound shall be Chico SpeedSeal or approved equal.
- j. An explosion-proof junction box shall be provided below the control panel for each motor control cable.
- k. Power cords must be one-piece construction with sufficient length to extend from the pump to the control panel. Splices will not be permitted.
- l. Control sequence shall be designed so that panel returns to normal automatic operation after a power failure. Manual reset shall not be necessary. The control sequence shall also be designed to allow back up float operation in the event of a level controller failure.
- m. A time delay relay to prevent the pumps (duplex) from starting simultaneously after power failure.
4. Alarm
- a. A weatherproof, red-flashing, incandescent or LED alarm light shall be provided and be mounted in a location visible from the access road. There shall also be an audible horn alarm rated at ninety decibels (90 db) at ten feet (10'). The alarm light and horn shall indicate a high wet well level alarm condition or power failure.
- b. Alarm power shall be derived from the one hundred and twenty Volt (120 V)



**PHENIX CITY**  
*Alabama*

**UTILITIES DEPARTMENT**

Physical Address: 1119 Broad Street  
Phenix City, AL 36867

Mailing Address: P.O. Box 760  
Phenix City, AL 36868

Ph: 334-448-2880

Fx: 334-291-4742

phenixcityal.us

- control power and battery backup.
- c. A silencing switch for the audible alarm shall be located inside the control panel.
- 5. Liquid Level Controls
  - a. The design pump control elevations shall be shown on the pump station construction drawings and shall control as follows:
    - 1) All Pumps Off; low water level
    - 2) Lead Pump On; shall alternate on each call
    - 3) Lag Pump On/Warning Alarm; both pumps running
    - 4) High Level Alarm; activate alarm light and siren
  - b. The controller shall use a 4-20 milliamps (mA) level instrument as the primary level indication and two float inputs for back-up control.
    - 1) The level instrument shall be a loop-powered submersible level transducer and units of measurement in "feet of water."
  - c. The level transducer shall be wired per the Manufacturer's Certification Drawings for Intrinsically Safe Circuits to meet Class I, Division 1, Group D area classification. The manufacturer's literature and device nameplate must call out hazardous area (Class I, Division 1, Group D) approval.
  - d. The float leads, submersible level transducer cables, and pump cords shall not be located near the incoming flow or the turbulence of the incoming sewer line.
  - e. The float leads and pump cords shall be suspended with stainless steel kellum grips from the bracket supplied by the pump manufacturer. The bracket shall be attached to the wet-well hatch frame or firmly bolted to the concrete immediately below the hatch frame. The bracket shall be positioned so the float leads and pump cords are easily accessible without entering the wet-well.
  - f. The float wires shall be neatly routed away from the pump access hatch opening then through the chamber access conduit, without excessive wire strain or pull.
  - g. Wire length on all float wires shall be such that each float may be adjusted to the bottom of the station wet-well.
  - h. The floats shall be hermetically sealed and intrinsically safe, and shall be Roto-Float Type S or approved equal.
- I. Wet Well
  - 1. The wet well shall be pre-cast concrete with a protective PVC or HDPE liner cast into the concrete. Small fiberglass wet wells may be approved by the Phenix City Utilities Department on a case by case basis.
  - 2. The minimum thickness of the liner shall be .065 inch, and the material shall have locking extensions spaced a maximum of 2.5 inches apart by 3.75 inches high.





**PHENIX CITY**  
*Alabama*

**UTILITIES DEPARTMENT**

Physical Address: 1119 Broad Street  
Phenix City, AL 36867

Mailing Address: P.O. Box 760  
Phenix City, AL 36868

Ph: 334-448-2880

Fx: 334-291-4742

phenixcityal.us

3. The PVC or HDPE liner shall be spark tested upon finishing of the installation in the field and any defects identified shall be repaired to the satisfaction of the City of Phenix City.
  4. Alternate spray-on protective coatings (SpectraShield or approved equal) may also be approved for wet well applications.
  5. The floor of the wet well shall be sloped towards the pump intakes to facilitate solids removal and shall be designed according to the pump selection. The minimum slope allowed for the floor of the wet well shall be one horizontal foot to one vertical foot ratio (1H:1V).
  6. The wet well dimensions shall be as shown on the construction drawings and as recommended by the pump manufacturer. The wet well depth shall in no case be less than 5 feet from the floor elevation to the lowest wet well invert elevation. The wet well diameter shall be a minimum of 5 feet.
  7. All penetrations into the wet well shall have gas-tight and water-tight seals.
  8. The wet well shall be vented through an isolated 4 inch diameter schedule 40 stainless steel vent pipe in the top of the wet well. The vent pipe shall be turned down one hundred and eighty degrees (180°) and shall be equipped with a screen to prevent animal or pest intrusion.
- J. Valve Vault
1. The valve vault shall include at a minimum a check valve, an isolation valve, an air release valve, and a pressure gauge for each submersible pump discharge.
  2. The individual pump discharges shall manifold into a single force main inside the valve vault.
  3. All appurtenances and fittings inside the valve vault shall be flanged and shall be properly supported and restrained.
  4. All piping and assemblies should be centered in the valve vault.
  5. The valve vault shall be of adequate size to allow a minimum of twelve inches (12") spacing around all appurtenances, and between paralleling appurtenances where possible for maintenance and repair.
  6. A flexible connection shall be provided inside the valve vault for each pump discharge.
  7. The depth of the valve vault shall be no greater than necessary to accommodate the necessary piping and assemblies and shall be no more than six feet (6') deep from the lid to the floor elevation.
  8. A drain pipe with a minimum diameter of two inches (2") shall be installed from the valve vault to the wet well. The drain shall include a flapper-style back-water check valve or similar device to prevent water and gasses from entering the valve pit. The floor of the valve vault shall be sloped as necessary to the drain piping to prevent standing water.



9. All penetrations into the valve vault shall have gas-tight and water-tight seals.
- K. Hatch
1. An aluminum, lockable hatch shall be provided on the wet well and valve vault and shall be rated for a minimum loading of three hundred pounds per square foot (300 psf) with a noncorrosive locking bar with a padlock hole of at least three eighths of an inch (3/8") (10 millimeters [mm]) (Halliday Products, Thompson Fabrication, or approved equal).
  2. All hardware shall be A.S.T.M. A276 Type 316 Stainless Steel.
  3. The frame and cover shall be cast into the concrete and shall be flush with the top of the concrete.
  4. The hatch shall be equipped with compression springs, an automatic hold-open arm, a water tight slamlock device, and a removable key wrench.
  5. The hatch shall be sized sufficiently to allow the maximum opening over the wet well and valve vault for access and maintenance.
- L. Access
1. All pump stations shall include a minimum twelve foot (12') wide access road constructed of 825B, asphalt, or concrete.
  2. Access roads constructed of 825B shall have a compacted thickness of at least twelve inches (12").
  3. Access roads constructed of asphalt shall consist of six inches (6") of crushed aggregate base (825B), two inches (2") of binder (424B), and one inch (1") of wearing surface (424A).
  4. Access roads constructed of concrete shall have 4,000psi minimum compressive strength at 28 days and shall have a minimum thickness of six inches (6").
  5. The access road and site shall be sloped to properly drain storm water. The maximum allowable grade on a pump station access road or site shall be 4 horizontal feet to 1 vertical foot ratio (4H:1V).
  6. The entire pump station site, inside the fenced area, shall be covered with 825B at a minimum compacted thickness of twelve inches (12") at eighty five percent (85%) standard proctor.
- M. Fencing
1. All pump station sites shall be enclosed with suitable security perimeter fencing. The fencing shall be 6-foot-high and shall typically be constructed of galvanized chain-link. The fencing shall be located so that a minimum five foot (5') spacing is provided between all pump station equipment and the fence perimeter.
  2. The chain-link fabric shall be a two inch (2") mesh woven from number nine (No. 9) gauge aluminum-coated steel or aluminum-zinc alloy conforming to ASTM A491 or A783.
  3. Aluminum-coated steel fabric shall be given a clear organic coating after fabrication.



4. Aluminum-zinc alloy coating on steel fabric shall be not less than forty seven hundredths of an ounce per square foot (0.47 oz/sf) of uncoated wire surface.
  5. The framework of the fencing shall be galvanized steel conforming to ASTM F1083 or ASTM A123, with not less than one and eight tenths ounces (1.8 oz) of zinc per square foot of surface, or steel conforming to ASTM A569 externally triple-coated with hot-dip galvanizing at one ounce per square foot (1 oz/sf).
  6. All fence fittings shall be galvanized according to ASTM A153, with zinc weights per Table 1.
  7. The chain-link fencing shall include three strands of barbed wire conforming to ASTM A585-81, Type 1 located at the top held out at a forty five degree (45°) angle on galvanized supports.
  8. The bottom tension wire shall be number seven (No. 7) gauge aluminumcoated steel conforming to ASTM A824, Type 1.
  9. The post tops shall be designed as weather-tight closure caps for tubular posts.
  10. Continuous fence shall be grounded at each corner post and at intervals not to exceed five hundred feet (500').
  11. At least one lockable gate shall be provided into the pump station site centered on the access road. The gate shall be a minimum of twelve feet (12') wide and shall provide an unobstructed path for maintenance vehicles to the wet well, valve vault, and standby pump and/or generator. The access gate shall not be placed over a manhole.
  12. The gate shall either be hinged and free to rotate to both the interior and the exterior of the fenced site as needed or installed on a roller wheel assembly sized to adequately support the weight of the gate and allowing the gate to slide open in a parallel direction to the fence.
  13. Gates shall be constructed of the same material as the perimeter fencing.
- N. Lighting
1. All pump station sites shall be equipped with suitable security lighting. The lighting shall be controlled with a photocell, with an additional on/off switch located in the lockable control panel.
- O. Potable Water Service
1. A one inch (1") water service with standard single three fourths of an inch (3/4") meter and meter box with a customer side shutoff valve and yard hydrant (Simmons 800 series or approved equal) shall be provided from the potable water service.
  2. The yard hydrant shall be located near the fence in an area that does not hinder or obstruct maintenance of the pump station or gate access.
  3. A testable reduced-pressure backflow assembly is required on all potable water service lines serving a sanitary sewer pump station.





P. Generators

1. General:

- a. The standard for generators shall be natural gas or diesel driven.
- b. The Supplier shall be a company specializing in packaged engine generator system with minimum three years' experience. The Supplier shall be an authorized distributor of an engine generator manufacturer with service facilities within 100 miles of project site at time of delivery. The supplier must carry sufficient inventory to cover no less than 80% parts service within 24 hours and 95% within 48 hours. If, within the two-year warranty period of the unit, spare parts are not available within the time frame described herein, the manufacturer shall provide and connect a portable unit to be used until the parts are received and installed and the original unit is again operational. If warranty work is necessary, the Supplier shall supply all parts and labor required to restore the engine generator system to operational condition.
- c. Supplier shall provide a two-year warranty for all major parts and equipment.
- d. Furnish service and maintenance of packaged engine generator system for two years from date of delivery. Maintenance shall include a 6-month inspection and annual PM each year with oil and filter changes, and oil testing. Manufacturer shall provide the owner the option to extend the maintenance contract at the end of the two-year period.

2. Submittals

- a. Submit product data showing dimensions, weights, ratings, interconnection points, and internal wiring diagrams for engine, generator, control panel, battery, battery rack, battery charger, exhaust silencer, enclosure, vibration isolators, fuel system, tank and radiator.
- b. Submit manufacturer's installation instructions. Include instructions for normal operation, routine maintenance requirements, service manuals for engine, oil sampling and analysis for engine wear, and emergency maintenance procedures.
- c. Submit manufacturer's certification stating that "This is to certify that we have examined the Plans and Specifications for this Project and have ascertained that this generator and accessories are suitable for the purpose and use intended."
- d. Submit manufacturer's operation and maintenance data.
- e. Furnish one set of tools per generator for preventative maintenance of the engine generator system. Package tools in adequately sized metal toolbox with provisions for storage within the unit enclosure.
- f. Provide two additional sets of each fuel, oil, and air filter element required for each engine generator system.



3. Warranty

- a. Engine and generator set shall carry a Standard Two Year Warranty for Standby Power Systems. Contractor shall provide a scheduled maintenance agreement with a local generator manufacturer's authorized Dealer. Contractor shall provide a startup inspection by the authorized dealer and act as Owner's agent in obtaining warranty service.

4. Design and Construction:

a. Manufacturer:

- 1) Engine and generator set shall be manufactured by Generac Power Systems, Katolight Corporation, Kohler Power Systems, Caterpillar, or an approved equal.

b. Engine:

- 1) The engine shall be of a water cooled inline or V-type, four stroke cycle, natural gas or diesel internal combustion engine.
- 2) The engine shall be sufficient to operate at 100 percent rated load for the duration of any power outage at specified elevation and ambient limits.
- 3) The engine speed shall be rated at 1800 rpm.
- 4) The engine governor shall be a mechanical type (under 200 KW) and isochronous type (200 KW and larger) to maintain engine speed within 0.5 percent, steady state, and 5 percent, no load to full load, with recovery to steady state within 2 seconds following sudden load changes. (Governor shall be capable of providing regulation when the load has a high reactive/capacitive component)
- 5) The engine safety devices shall shutdown the engine on low water level, high water temperature, low oil pressure, over speed, and engine overcrank. Limits shall be selected by manufacturer. All safety devices shall be connected to a common fault output for future connection.
- 6) The DC starting system with positive engagement, number and voltage of starter motors shall be in accordance with manufacturer's instructions. Remote starting control circuit, with MANUAL-OFF-REMOTE selector switch on engine-generator control panel shall be included. When this switch is not in "REMOTE" (Auto), it shall output a fault signal to the common fault alarm.
- 7) The Engine Block Heater shall be suitable for operation at 120 volts.
- 8) The radiator shall use glycol coolant, with blower type fan, sized to maintain safe engine temperature in ambient temperature of 110 degrees F (43 degrees C). Radiator airflow restriction shall be 0.5 inches of water (9.34 mm of mercury), maximum.
- 9) Engine Accessories shall include fuel filter, lube oil filter, intake air filter,



lube oil cooler, fuel transfer pump, fuel priming pump, gear-drive water pump, water temperature gauge, and lube oil pressure gage on engine-generator control panel.

10) Mounting shall provide unit with suitable vibration isolators for mounting on structural concrete base.

c. Generator

- 1) The generator shall be an ANSI/NEMA MG 1 three phase, four pole, reconnectible brushless synchronous generator with brushless exciter.
- 2) The generator shall have a unit capacity suitable to run all pumps at the lift station.
- 3) The generator insulation shall be ANSI/NEMA MG 1, Class F.
- 4) The generator shall have a 150 degree C standby temperature rise.
- 5) The generator enclosure shall be ANSI/NEMA MG 1 rated and shall be open drip proof.
- 6) Voltage Regulation shall include generator-mounted volts per Hertz exciter-regulator to match engine and generator characteristics, with voltage regulation +/- two percent from no load to full load and shall include manual controls to adjust voltage drop +/- 5 percent voltage level and voltage gain.
- 7) The generator shall be capable of delivering full load amps with up to 5% total harmonic distortion.
- 8) The generators shall have PMG (permanent magnet generator) exciters.
- 9) The manufacturer shall provide computer generated analysis of the generator showing that the proposed generator is capable of starting and operating electrical loads of the wattage ratings necessary. The system should be designed to accommodate loads starting at the same time.

d. Accessories

- 1) Fuel System: Natural Gas or Diesel
- 2) Exhaust Silencer: Critical type silencer, with muffler companion flanges and flexible stainless steel exhaust fitting, suitable for horizontal orientation, sized in accordance with engine manufacturer's instructions.
- 3) Batteries: Heavy duty, diesel starting type lead-acid storage batteries, with cold cranking amps and ampere-hour rating as required by the manufacturer. Match battery voltage to starting system. Include necessary cables and clamps.
- 4) Battery Tray: Plastic coated metal, constructed to contain spillage of electrolyte.
- 5) Battery Charger: Ten ampere, float-type, current limiting type designed to float at 2.17 volts per cell and equalize at 2.33 volts per cell. Include





- overload protection, full wave rectifier, DC voltmeter and ammeter, and 120 volts AC fused input. Provide enclosure to meet ANSI/NEMA 250, Type 1 requirements. Battery chargers shall be mounted within the generator enclosure.
- 6) Line Circuit Breaker: NEMA AB 1 molded case circuit breaker on generator output with integral thermal and instantaneous magnetic trip in each pole; sized in accordance with ANSI/NFPA 70. Include battery-voltage operated shunt trip, connection to open circuit breaker on engine failure. Mount unit in enclosure to meet ANSI/NEMA 250, Type 1 requirements. The breakers shall be clearly and appropriately marked in 2-inch high numbers and letters.
- 7) Engine-Generator Control Panel: ANSI/NEMA 250, Type 1 generator mounted control panel enclosure with engine and generator controls and indicators. Include provision for padlock and the following equipment and features:
- i. Frequency Meter: 45-65 Hz range, 3-1/2 inch (89 mm) dial.
  - ii. AC Output Voltmeter: 3-1/2 inch (89 mm) dial, 2 percent accuracy, with phase selector switch.
  - iii. AC Outlet Ammeter: 3-1/2 inch (89 mm) dial, 2 percent accuracy, with phase selector switch.
  - iv. Output voltage adjustment.
  - v. Push-to-test- indicator lamps, one each for low oil pressure, high water temperature, overspeed, and overcrank.
  - vi. Engine start/stop selector switch.
  - vii. Engine running time meter.
  - viii. Oil pressure gage.
  - ix. Water temperature gage.
  - x. Auxiliary Relay: 3 PDT, operates when engine runs, with contact terminals prewired to terminal strip.
  - xi. Remote Alarm Contacts: Pre-wire SPCT contacts to terminal strip for remote alarm functions required by ANSI/NFPA 99. Also included in this alarm shall be a "Not in Automatic" signal.
  - xii. Provision for regularly scheduled starting and operation of engine generator for maintenance purposes.
  - xiii. Overvoltage shutdown.
- 8) Microprocessor control panel which shall include a common fault contact for connection to existing or future SCADA systems by others.
- 9) Sound attenuating enclosure: reinforced steel housing allowing access to control panel and service points, with lockable doors, fixed louvers, and



- panels. Enclosure shall be sized large enough to house battery rack, battery charger, and silencer.
- 10) Enclosure to be in Engineer's Choice of Color which may not be the Manufacturers standard color. The Owner's selected color shall be provided at no additional costs to the Owner.
- 11) The generator shall have an isolated neutral bus installed in an easily accessible location adjacent to or near the line circuit breaker.
- Q. Pump Station Inspection - All sanitary sewer pump stations shall be thoroughly inspected during construction and at the end of construction prior to acceptance by the Phenix City Utilities Department.
1. Final Inspection
- The final inspection shall be arranged through the Phenix City Utilities Department. The final inspection shall show that the pump station is fully operable and all necessary appurtenances have been installed and constructed in accordance with all applicable design and installation standards as well as the approved construction drawings.
  - Representatives from the Contractor, the installing electrical contractor, any applicable subcontractors, the Project Engineers (civil, electrical, etc.), and the pumping equipment manufacturer shall be present at the pump station site for the final inspection in addition to the City of Phenix City representatives.
  - The Contractor shall subject all the pumping equipment including all submersible pumps, and the standby diesel pump to operating tests for all possible pumping scenarios to demonstrate satisfactory performance of the equipment including proper controls and float switch operation. All equipment associated with the pump station shall be tested for proper operation.
  - If tests do not demonstrate satisfactory performance of the equipment, deficiencies shall be corrected and equipment shall be retested.
  - If sufficient waste water or storm water to test the pumps is not available when the final inspection is scheduled, the Contractor shall arrange to obtain a sufficient volume of water, at the Contractor's expense, from the public water supply for the test. The minimum quantity of water to be pumped for the test shall be equivalent to one and one half (1.5) minutes of continuous pumping at rated pump capacity for each pump operating alone and for every possible combination of pumps operating simultaneously. Each pump combination shall be tested a minimum of two (2) times.
  - All pump station equipment shall be tested by the contractor prior to requesting a final inspection. At a minimum each pump shall be started with the voltage, current and other significant parameters being recorded. The manufacturer shall provide a formal test procedure and forms for recording





data. The recorded data shall be submitted to the Phenix City Utilities Department in conjunction with the as-built electrical schematics before the final inspection is requested with the City of Phenix City.

- g. All ground surrounding the pump station must be graded, seeded, and mulched per the City of Phenix City requirements and satisfactory erosion control measures installed and functioning properly prior to scheduling a final inspection.
  - h. The following documentation and items shall be provided to the Phenix City Utilities Department as a minimum prior to scheduling a final pump station inspection:
    - 1) Three (3) sets of as-built wiring and piping schematics of the pump station site and any station access areas.
    - 2) Three (3) sets of operation and maintenance manuals, "asbuilt" drawings, O&M Manuals, copies of certified tests, and inspection data.
    - 3) Warranty documents.
    - 4) One (1) spare impeller for each pump.
    - 5) Two (2) seal assemblies for each pump: top and bottom at impeller and at winding of motor.
    - 6) One (1) complete set of bearings for each pump.
    - 7) One (1) additional level float switch (normally open type) with sufficient cable for the lowest level float.
    - 8) O-ring and gasket kit for each pump motor and impeller housing.
    - 9) One (1) complete set of spare fuses for all electrical devices.
    - 10) Ten (10) spare bulbs for each lamp type.
    - 11) Two (2) sets of keys to standby diesel pump enclosure.
    - 12) Standby pump fuel tank shall be filled to capacity.
- X. **TESTING** – Sewer structures shall be thoroughly cleaned and maintained in workable condition until final acceptance. If ground water or storm water infiltration is occurring after the pipe is installed, the Contractor shall find and repair any problem areas. Infiltration shall be evident by visible flow in pipes or wet spots in manholes.
- A. Visual Tests (required)
    - 1. All materials shall be subject to being visually inspected by the Inspector at the site for conformance to the required specifications. When reasonable doubt exists that said material meets the specifications, the City of Phenix City may require certified mill tests, samples, and/or tests by an independent laboratory or other suitable form of verification that the material meets the required specifications.
    - 2. Sewer lines are subject to be inspected for alignment after the pipe has been backfilled and compacted to one foot (1') above the pipe. However, approval of this



**PHENIX CITY**  
*Alabama*

**UTILITIES DEPARTMENT**

Physical Address: 1119 Broad Street  
Phenix City, AL 36867

Mailing Address: P.O. Box 760  
Phenix City, AL 36868

Ph: 334-448-2880

Fx: 334-291-4742

phenixcityal.us

- stage shall not relieve the Contractor of liability should misalignment occur during subsequent backfilling or construction. If inspector is not available to inspect the pipe at this stage, the Contractor is still liable for any misalignment.
3. The Inspector will visually inspect the sewer and construction site periodically during construction and at the completion of construction. The Contractor shall immediately repair all noted leaks, defects, and deficiencies upon such inspection.
  4. Sewers shall be built so as to remain true to line and grade. Any section of pipe that does not comply with the specifications at any time previous to final acceptance of the work shall be replaced or re-laid at the Contractor's expense.
  5. The Contractor will be held strictly responsible that all parts of the work bear the load of the backfill. If cracks one hundredth of an inch (0.01") develops in the pipe prior to the City of Phenix City accepting the sanitary sewer for maintenance, the Contractor will be required to replace, at his expense, all such cracked pipe. To this end, the Contractor is advised to purchase pipe under a guarantee from the manufacturer, guaranteeing proper service of sewer pipe under conditions established by the construction drawings, specifications, and local conditions at the site of the work.
  6. All inverts must be completed and inspected before proceeding with the CCTV, mandrel and/or pressure tests except in doghouse manholes where the tests may be performed before the inverts are complete and the existing main is cut.
  7. A closed circuit television (CCTV) inspection of the sanitary sewer is required prior to issuance of a certificate of occupancy or acceptance of the final subdivision plat by the City of Phenix City.
    - a. The CCTV inspections provided by the developer require the following:
      - 1) Videos must begin above ground with visual evidence of the location of the beginning manhole
      - 2) Video must be clear enough to see small objects in the pipe
      - 3) Video must look at each joint and service connection
      - 4) Video must look at objects closely if it is not obvious what the objects are
      - 5) Video must have a date and distance indicator in feet
      - 6) Video distance indicator must start at zero at beginning manhole.
    - b. When the City of Phenix City's CCTV van is available, the City of Phenix City provides CCTV inspection services as a courtesy to the developer at no cost to the developer the first time the sanitary sewer is televised and charges a fee for all subsequent CCTV inspections. Any CCTV inspections after the first, will be at the current rate as per the City of Phenix City water and sewer rates and shall be paid by the contractor within thirty (30) days of receiving the CCTV invoice from the City of Phenix City.
    - c. The developer is required to have a CCTV inspection performed on the sanitary



**PHENIX CITY**  
*Alabama*

**UTILITIES DEPARTMENT**

Physical Address: 1119 Broad Street  
Phenix City, AL 36867

Mailing Address: P.O. Box 760  
Phenix City, AL 36868

Ph: 334-448-2880

Fx: 334-291-4742

phenixcityal.us

- system whether the City's CCTV van is available or not. The City is not required to pay you or the developer to have the CCTV inspections performed even if the City's CCTV van is not available.
- d. If the developer wishes to have the City of Phenix City perform CCTV inspections, the contractor shall submit a written request to the Phenix City Engineering Department for any CCTV inspection stating that the sanitary sewer is ready for inspection.
  - e. If the City of Phenix City's CCTV system is not available, the developer is responsible for having the CCTV inspections performed.
  - f. Any deficiencies found by the CCTV inspection shall be corrected by the contractor at his own expense prior to the issuance of a certificate of occupancy or acceptance of the final subdivision plat by the City of Phenix City and will require an additional CCTV inspection by the City of Phenix City to confirm that the deficiencies have been corrected.
8. The City of Phenix City may require additional tests, including but not limited to mandrel testing of pipe and vacuum testing of manholes, based on the results of visual inspections.
- B. Hydrostatic Pressure Testing of Force Mains (required)
1. Sanitary sewer force mains shall be filled with water and pressure tested at two hundred pounds per square inch (200 psi) for two hours (2 hrs.) and shall not show a loss of more than five pounds per square inch (5 psi) over such time. If the system fails the tests, necessary repairs shall be made and lines shall be retested.
  2. Air should be expelled from the line before testing.
  3. It shall be the contractor's responsibility to pass the pressure test. Any extra valves, taps, plugs, or bracing required to perform testing procedures will be at the contractor's expense.
  4. All air release valves shall be isolated or removed prior to flushing and pressure testing the line.
  5. Each valved section of pipe shall be slowly filled with clean water and the specified pressure shall be applied by means of a pump connected to the pipe in a satisfactory manner. The pump, pipe connection, gauges, meters and other apparatus required for the tests shall be furnished and installed by the Contractor.
- C. Low Pressure Air Testing for Gravity Mains (required) – Low pressure air tests are required for all sanitary sewer mains unless the low pressure test cannot be performed due to the pipe diameter being too large to plug.
1. The Contractor shall furnish all equipment, facilities, and personnel necessary to conduct the test. A representative of the City of Phenix City shall observe the test.
  2. Air test shall be performed after all services have been installed and backfilling has been completed and compacted.





**PHENIX CITY**  
*Alabama*

**UTILITIES DEPARTMENT**

Physical Address: 1119 Broad Street  
Phenix City, AL 36867

Mailing Address: P.O. Box 760  
Phenix City, AL 36868

Ph: 334-448-2880

Fx: 334-291-4742

phenixcityal.us

3. The pipe shall be cleaned prior to testing. Cleaning may be performed by passing a full-gauge squeegee through the pipe. It shall be the Contractor's responsibility to have the pipe cleaned. Other methods to clean pipes shall be approved by the City of Phenix City prior to cleaning.
  4. Plug all pipe outlets with suitable test plugs, and brace each plug securely. Plugs used to close the sewer pipe for the air test must be securely braced to prevent the unintentional release of a plug, which can become a high velocity projectile. Locate gauges, air piping manifolds, and valves at the top of the ground. No one shall be permitted to enter a manhole where a plugged pipe is under pressure. Provide a safety release device set to release at ten pounds per square inch (10 psi) between the air supply and the sewer under test.
  5. Supply the air slowly to the plugged pipe installation until the internal air pressure reaches four pounds per square inch (4.0 psi). Allow at least two (2) minutes for temperature stabilization, adding only the amount of air required to maintain pressure. After two (2) minutes disconnect the air supply.
  6. The pipeline shall be considered acceptable when the pipe holds four pounds per square inch (4.0 psi) for two (2) minutes.
  7. If the pipe installation fails to meet these requirements, the Contractor shall determine at his own expense the source or sources of leakage and repair or replace all defective materials or workmanship. The completed pipe installation shall meet the requirements of this test before being considered acceptable. Regardless of the outcome of the tests, the contractor shall repair any noticeable leak.
- D. Mandrel Test (optional)
1. The City of Phenix City may require a mandrel test if a notable deflection or other deficiency is seen in the in the sanitary pipe CCTV inspection or other inspection.
  2. PVC sewer will be tested with a Go, No-Go mandrel, sized to allow a maximum of five percent (5%) deflection based on the internal diameter of the pipe.
  3. The Contractor is responsible for providing pull ropes, mandrel and the actual pulling of the mandrel in the presence of the City Inspector.
- E. Vacuum Testing for Manholes (optional)
1. All manholes shall be vacuum tested per ASTM C1244 - 93.
  2. Manholes shall be prepared by plugging all lift holes and pipes entering manhole. Care shall be taken to securely brace the pipes and plugs to prevent them from being drawn into the manhole.
  3. The test head shall be placed at the top of the manhole in accordance with manufacturers recommendations and a vacuum of ten inches (10") of mercury shall be drawn on the manhole, the valve on the vacuum line of the test head closed, and the vacuum pump shut off.



**PHENIX CITY**  
*Alabama*

**UTILITIES DEPARTMENT**

Physical Address: 1119 Broad Street  
Phenix City, AL 36867

Mailing Address: P.O. Box 760  
Phenix City, AL 36868

Ph: 334-448-2880

Fx: 334-291-4742

phenixcityal.us

4. The time shall be measured for the vacuum to drop to nine inches (9") of mercury.
5. The manhole shall pass if the time for the vacuum reading to drop from ten inches (10") of mercury to nine inches (9") of mercury meets or exceeds the values indicated in Table C.
6. If the manhole fails the initial test, necessary repairs shall be made by an approved method. The manhole shall then be retested until a passing test is obtained.

DRAFT

7.0 UTILITIES (POTABLE WATER AND SANITARY SEWER)



Table C - Minimum Test Times (sec.) Based On Manhole Diameter

Depth (ft.)	Outside or Inside Diameter (in.)									Time (Seconds)
	30	33	36	42	48	54	60	66	72	
8	11	12	14	17	20	23	26	29	33	
10	14	15	18	21	25	29	33	36	41	
12	17	18	21	25	30	35	39	43	49	
14	20	21	25	30	35	41	46	51	57	
16	22	24	29	34	40	46	52	58	67	
18	25	27	32	38	45	52	59	65	73	
20	28	30	35	42	50	53	65	72	81	
22	31	33	39	46	55	64	72	79	89	
24	33	36	42	51	59	64	78	87	97	
26	36	39	46	55	64	75	85	94	105	
28	39	42	49	59	69	81	91	101	113	
30	42	45	53	63	74	87	98	108	121	

XI. **MAINTENANCE** – The Contractor shall maintain all street and road surfaces, trench backfill and all completed sections of pipelines in good condition until the warranty period ends and the City of Phenix City accepts the subdivision infrastructure for maintenance. The Phenix City Utilities Department may use completed sections of the water mains when needed even prior to the City of Phenix City accepts the subdivision infrastructure for maintenance. However, such use shall not relieve the Contractor of his responsibility for maintaining or replacing defective work.

**APPENDIX 7D**  
**SANITARY SEWER DETAILS**

DRAFT

DRAFT



**TYPICAL BORE ENCASEMENT**

CARRIER PIPE		SPACER	STEEL ENCASEMENT	
NOMINAL PIPE DIAMETER	STANDARD PIPE BELL O.D.*	CASING SPACER BAND WIDTH	MINIMUM CASING THICKNESS	MINIMUM CASING DIAMETER**
4	6.40	8	0.25	14
6	8.60	8	0.25	16
8	11.16	8	0.25	18
10	13.25	8	0.25	20
12	15.22	8	0.25	22
14	17.73	12	0.3125	24
16	19.86	12	0.3125	26
18	22.16	12	0.3125	30
20	24.28	12	0.3125	32
24	28.50	12	0.3125	36
30	34.95	12	0.5	42
36	41.37	12	0.5	48

ALL SIZES INDICATED ARE IN INCHES

\*PIPE BELL OUTSIDE DIAMETER BASED ON PRESSURE CLASS 350 DUCTILE IRON PIPE.

\*\*CASING DIAMETERS BASED ON BEING A MINIMUM OF 6 INCHES GREATER THAN THE OUTER DIAMETER OF THE JOINT BELL, TO THE NEAREST EVEN SIZE.

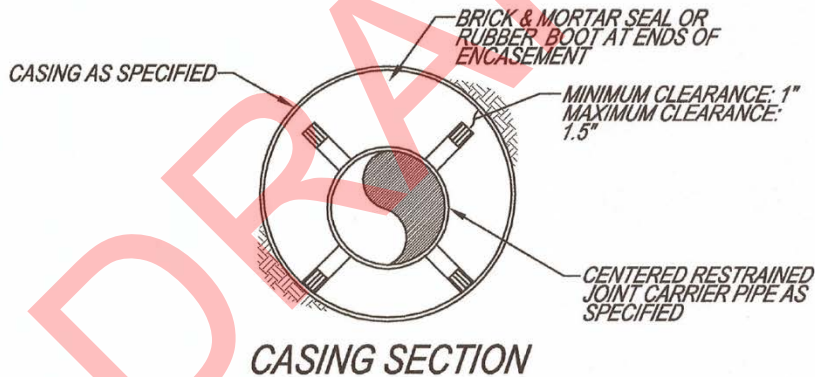

**CASING SECTION**

**NOTES**

1. ALL SPACER BANDS SHALL BE MADE FROM T-304 STAINLESS STEEL OF A MINIMUM 14 GAUGE THICKNESS.
2. ALL SPACERS SHALL HAVE A SYNTHETIC RUBBER OR PVC LINER TO INSULATE THE PIPELINE FROM THE SPACER.
3. ALL SPACERS SHALL HAVE 1.5" WIDE GLASS REINFORCED PLASTIC OR UHMW POLYMER RUNNERS TO INSULATE THE SPACER.
4. SPACERS TO BE MANUFACTURED BY CASCADE WATERWORKS MFG. CO. (PSI) PIPELINE SEAL AND INSULATOR, INC. OR EQUAL.
5. 4" THRU 12" DIAMETER PIPELINE SHALL USE 8" WIDE BANDS: GREATER THAN 12" DIAMETER PIPELINES SHALL USE 12" WIDE BANDS.
6. CENTERED RESTRAINED CASING SPACERS SHALL BE SPACED AT A MAXIMUM OF TEN FEET APART WITH A MINIMUM OF TWO SPACERS PER JOINT OF PIPE.
7. ALL PIPE SHALL BE COATED INSIDE AND OUT WITH AT LEAST ONE SHOP COAT OF AN APPROVED PRIMER PAINT. IN ADDITION, THE EXTERNAL SURFACE SHALL BE TREATED WITH ONE COAT OF ASPHALTUM PAINT, MEETING THE REQUIREMENTS OF FEDERAL SPECIFICATION TT-C-494B TYPE II, COMPOSITION G. FUSION-BONDED EPOXY COATING, MEETING THE REQUIREMENTS OF AWWA C213, MAY BE USED AS AN ALTERNATIVE TO THE SHOP COAT PRIMER AND ASPHALTUM PAINT.

DRAFT

**PIPE CONNECTION AT MANHOLE**

NOT TO SCALE

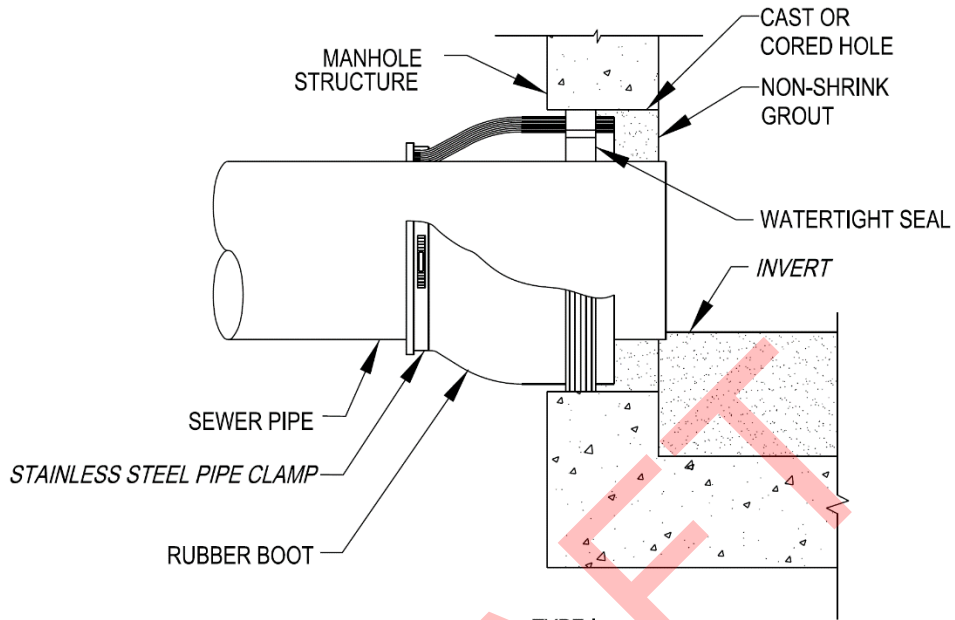

**TYPE I**

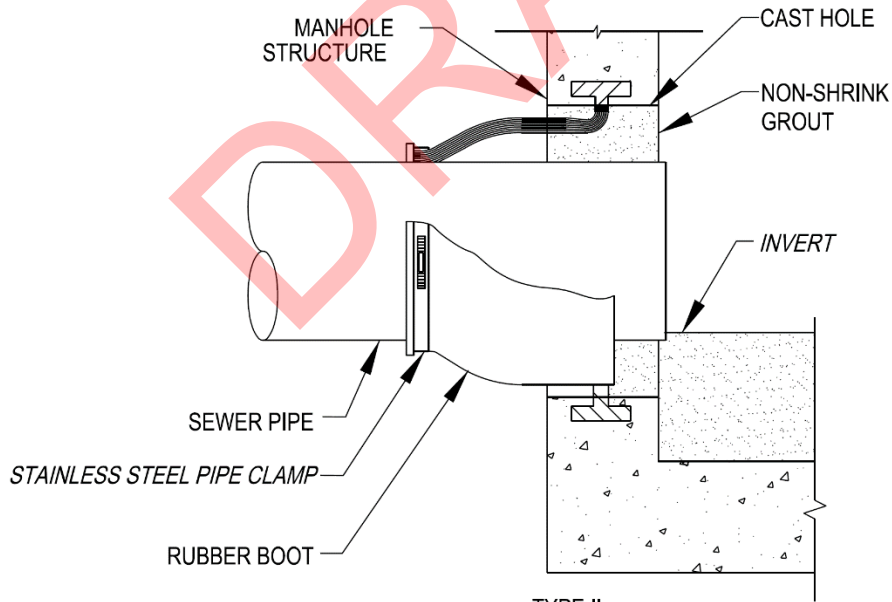

**TYPE II**

**NOTE:**

1. USE BOOTS FOR PIPES WITH DIAMETERS LESS THAN 42".
2. TYPE I IS FOR MECHANICALLY ATTACHED TYPE BOOTS.
3. TYPE II IS FOR CAST-IN BOOTS

DRAFT

**TYPICAL SADDLE MANHOLE**

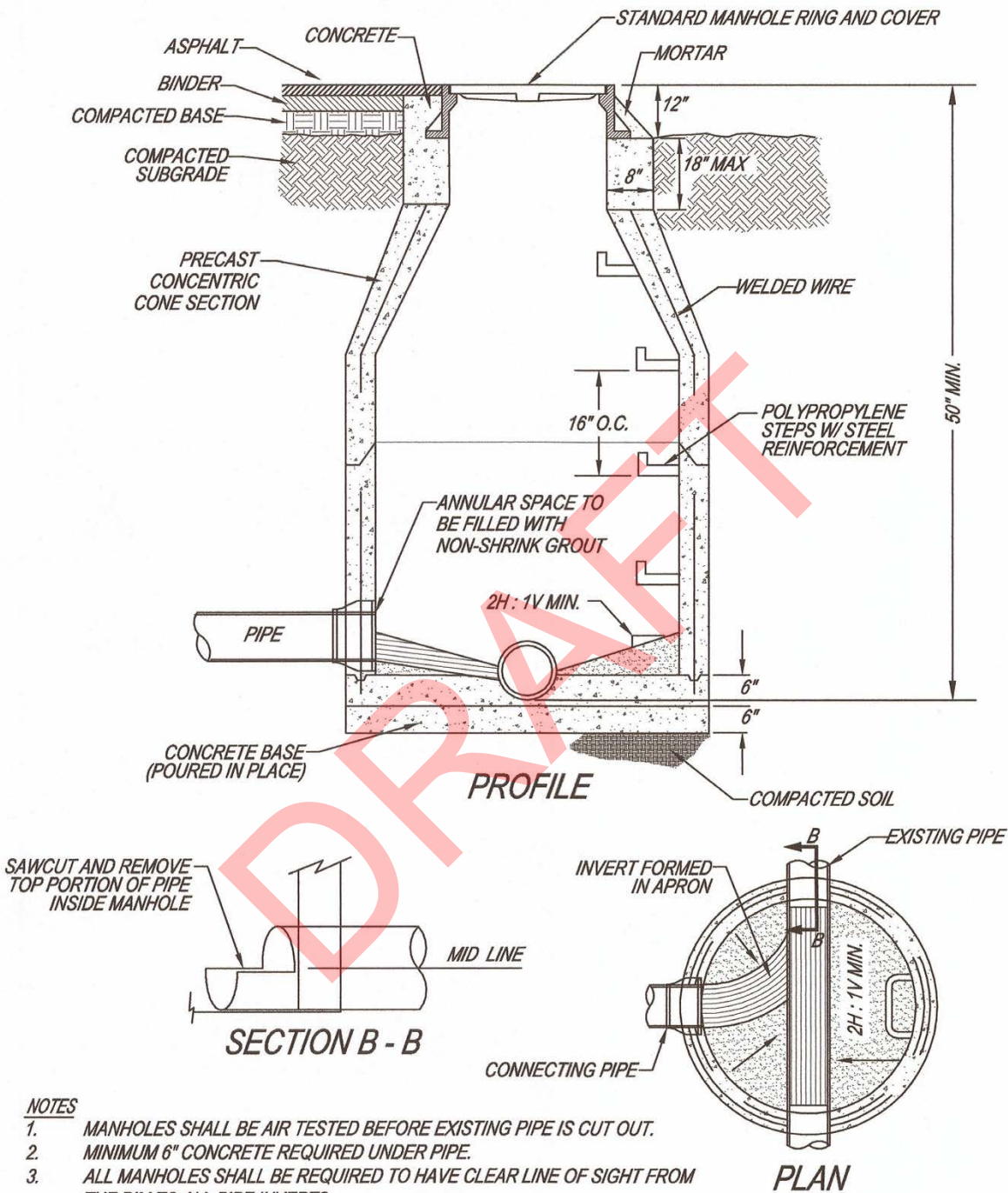

**NOTES**

1. MANHOLES SHALL BE AIR TESTED BEFORE EXISTING PIPE IS CUT OUT.
2. MINIMUM 6" CONCRETE REQUIRED UNDER PIPE.
3. ALL MANHOLES SHALL BE REQUIRED TO HAVE CLEAR LINE OF SIGHT FROM THE RIM TO ALL PIPE INVERTS.
4. ALL MANHOLE SECTIONS SHALL BE CYLINDRICAL SHAPED PRECAST STRUCTURAL CONCRETE.
5. ALL MANHOLES SHALL BE PROPERLY GROUTED AND WATER TIGHT.

DRAFT



## 7.0 UTILITIES (POTABLE WATER AND SANITARY SEWER)

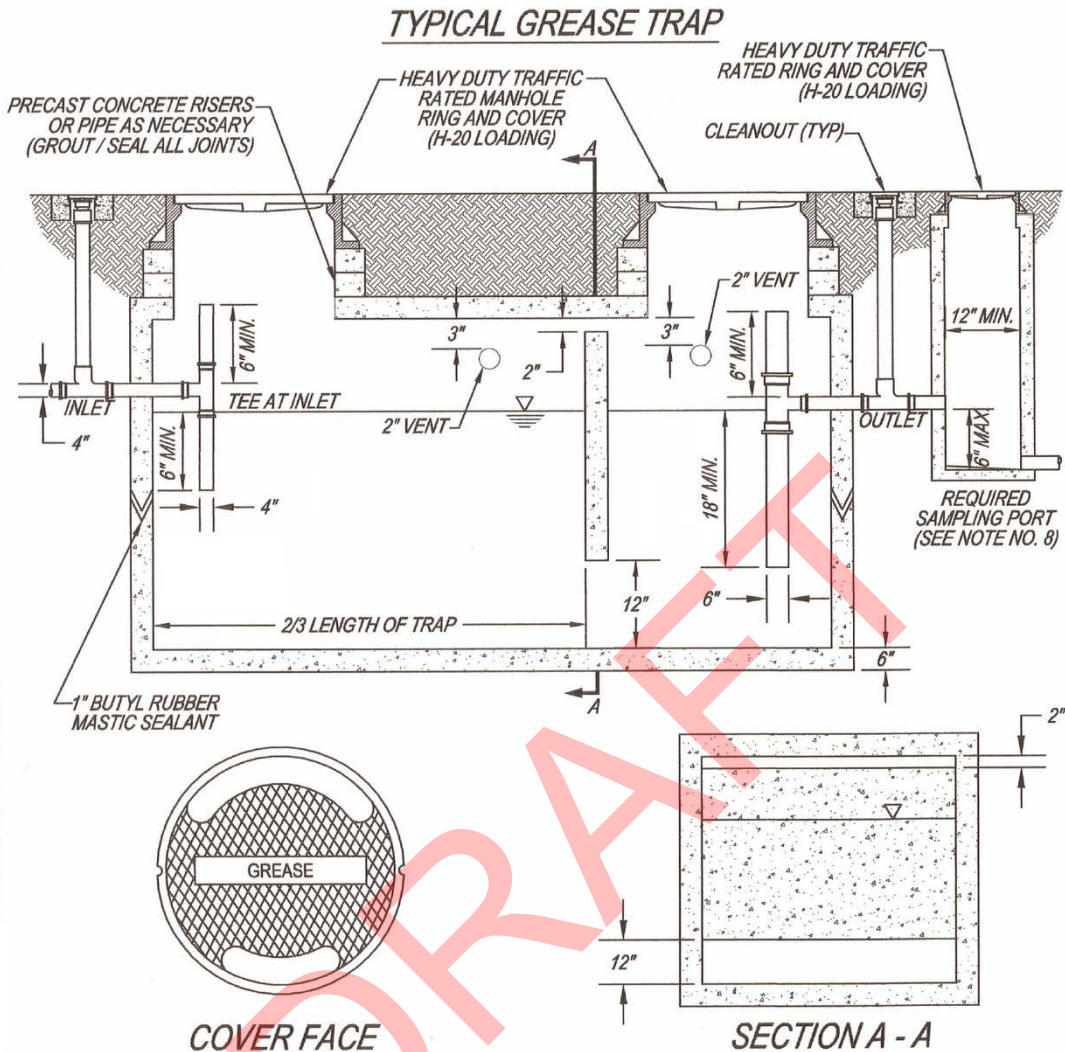

**NOTES:**

1. MANHOLE, RING AND COVERS SHALL NOT BE COVERED, OR OBSCURED BY LANDSCAPING, PAVEMENT, ETC.
2. INLET AND OUTLET PIPES SHALL BE SCHEDULE 40 PVC, AND SHALL NOT BE COVERED OR CAPPED.
3. INLET PIPE MUST BE A MINIMUM OF 4" IN DIAMETER. VERTICAL PIPE ON OUTLET SIDE MUST BE A MINIMUM OF 6" IN DIAMETER.
4. TRAPS SHALL NOT BE LOCATED IN AN ENTRANCE, EXIT, DRIVE-THRU, OR UNDER A MENU BOARD.
5. SIZE TO BE PER STANDARD SIZING WORKSHEET (MIN. 1000 GALLONS).
6. 2" DIAMETER VENTS TO BE CONNECTED TO BUILDING VENT SYSTEM (WHERE REQUIRED BY THE PLUMBING PLANS).
7. GREASE TRAPS SHALL MEET STATE OF ALABAMA HEALTH REGULATIONS SECTION 420-3-1-23; 420-3-1-24; 420-3-1-25
8. A DOWNSTREAM SAMPLING PORT OR MANHOLE WILL BE REQUIRED. NO OTHER CONNECTIONS ARE ALLOWED BETWEEN GREASE TRAP AND SAMPLING MANHOLE.
9. RESTROOM AND NON-GREASE LADEN WASTE SHALL NOT PASS THROUGH THE GREASE TRAP.

DRAFT



7.0 UTILITIES (POTABLE WATER AND SANITARY SEWER)

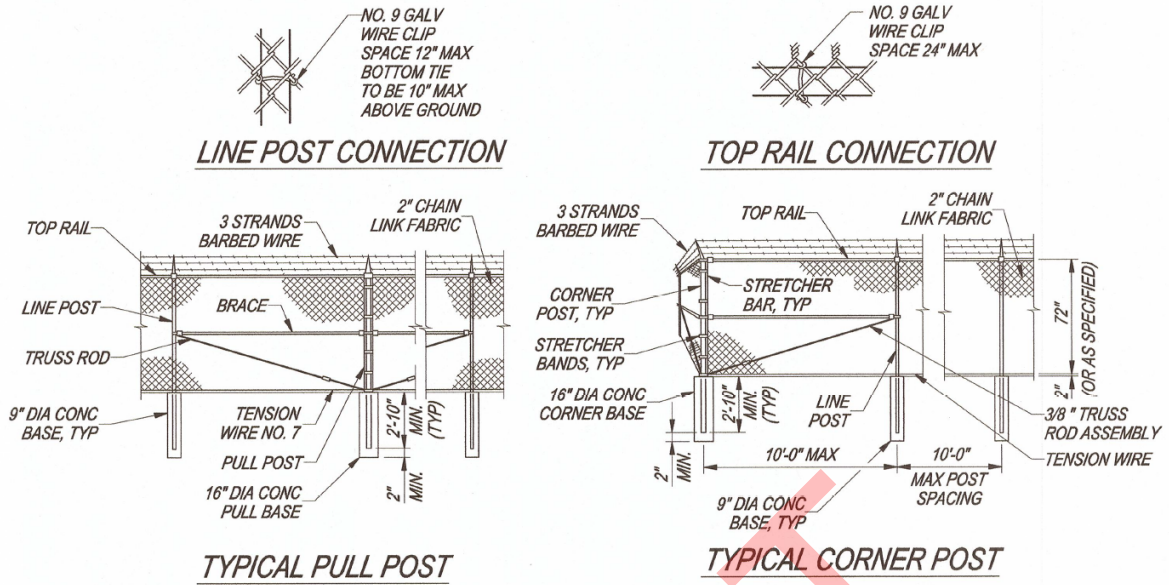

**FENCE NOTES:**

1. BRACE AND TRUSS ROD REQUIRED AT GATES AND SIDE OF ALL CORNER POSTS.
2. FABRIC ATTACHED TO OUTSIDE OF POSTS.

DRAFT

DRAFT

**7.0 UTILITIES (POTABLE WATER AND SANITARY SEWER)**

**GENERAL PUMP STATION SITE PLAN**

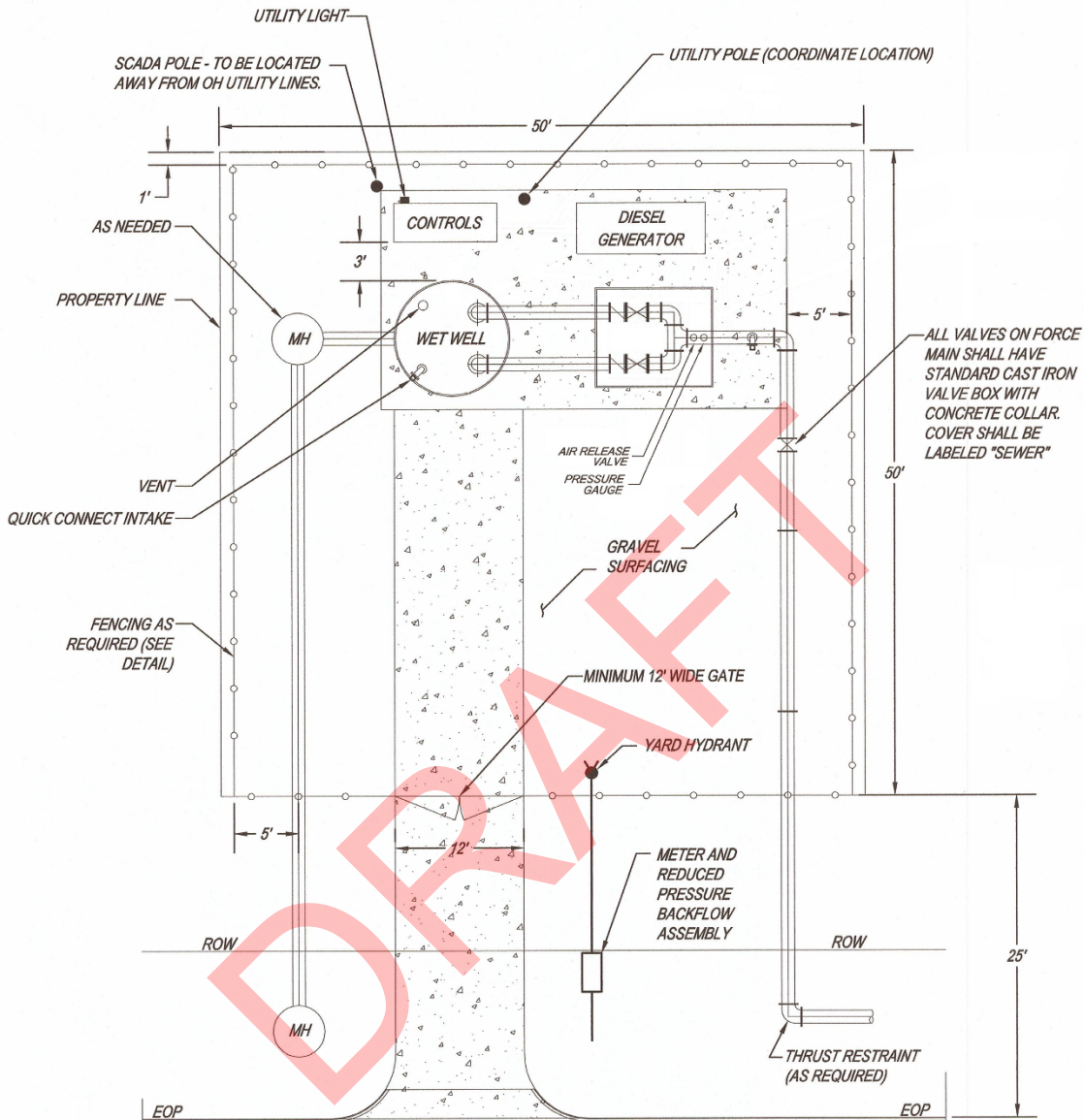

DRAFT

# 7.0 UTILITIES (POTABLE WATER AND SANITARY SEWER)

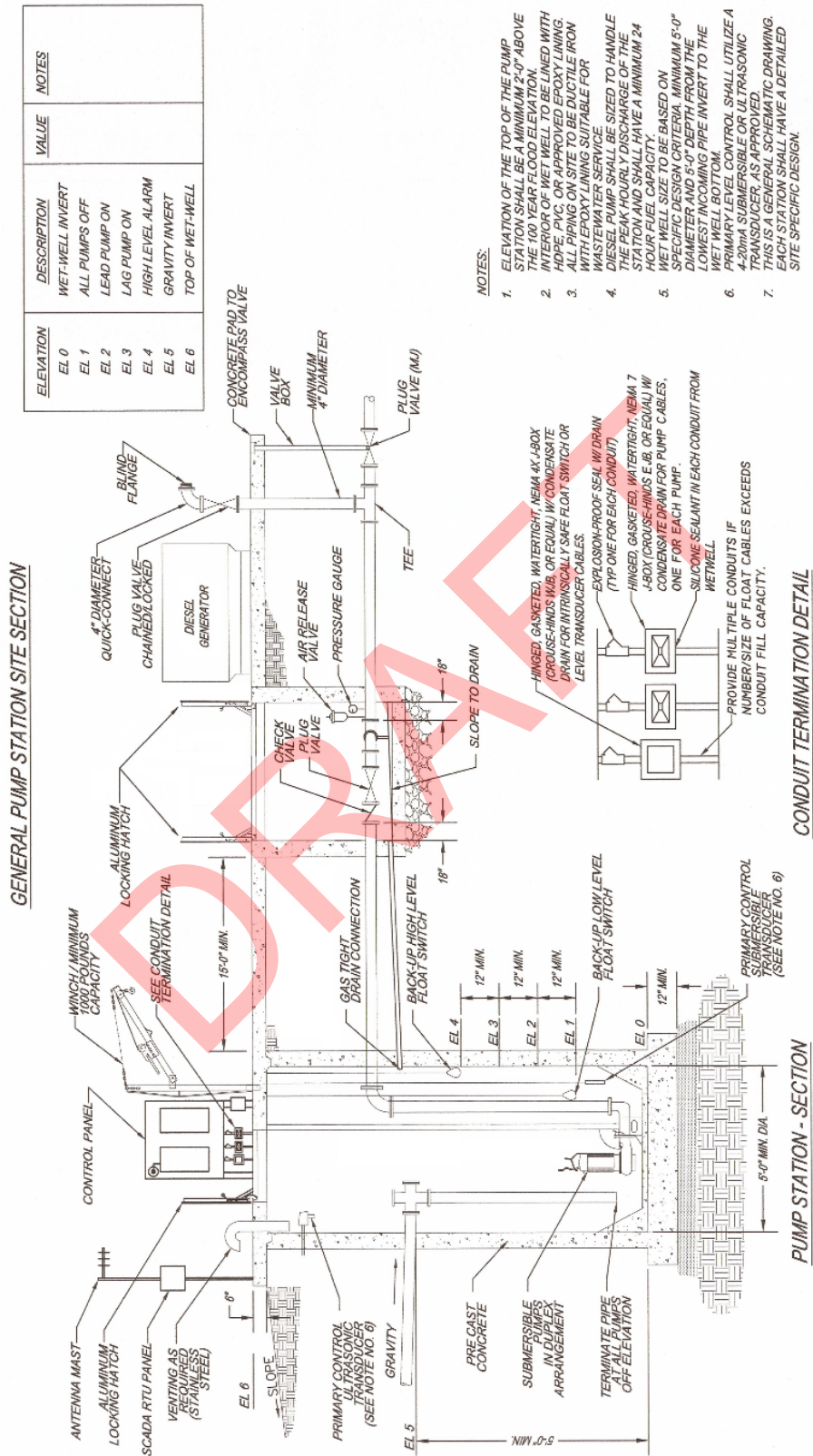

DRAFT

7.0 UTILITIES (POTABLE WATER AND SANITARY SEWER)

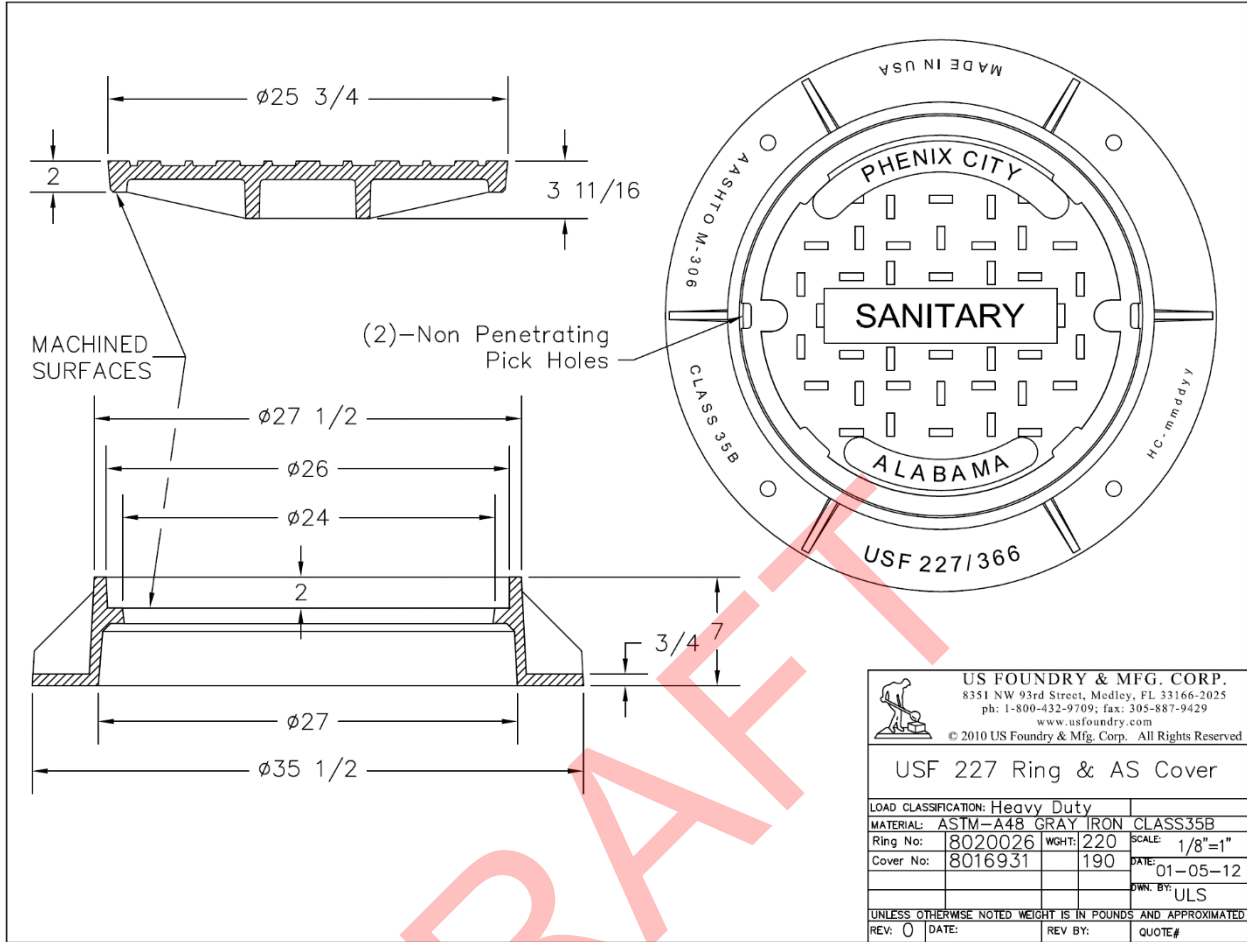

DRAFT



## 7.0 UTILITIES (POTABLE WATER AND SANITARY SEWER)

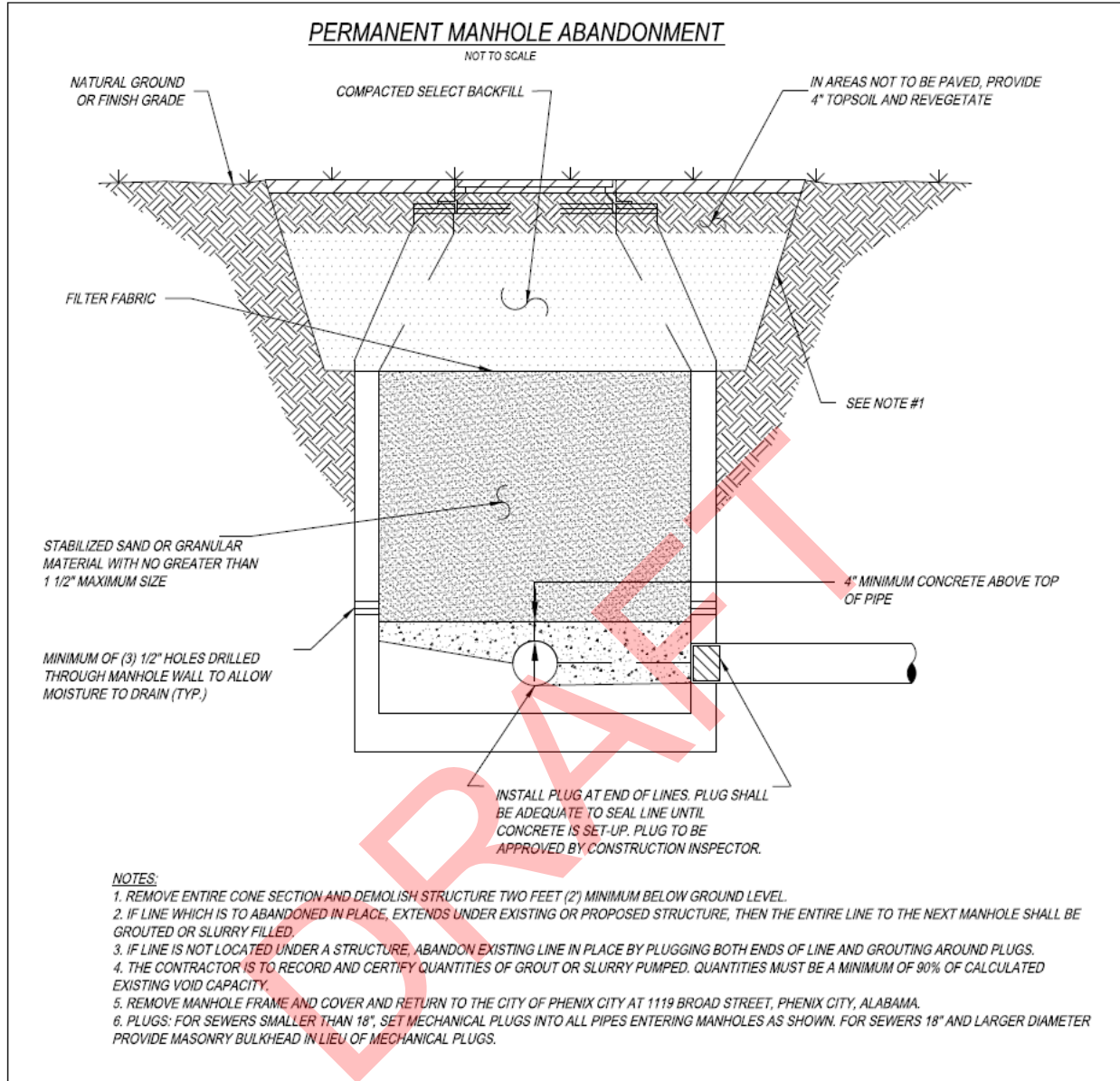

DRAFT

**TYPICAL 4" OR 6" DROP SERVICE LINE**

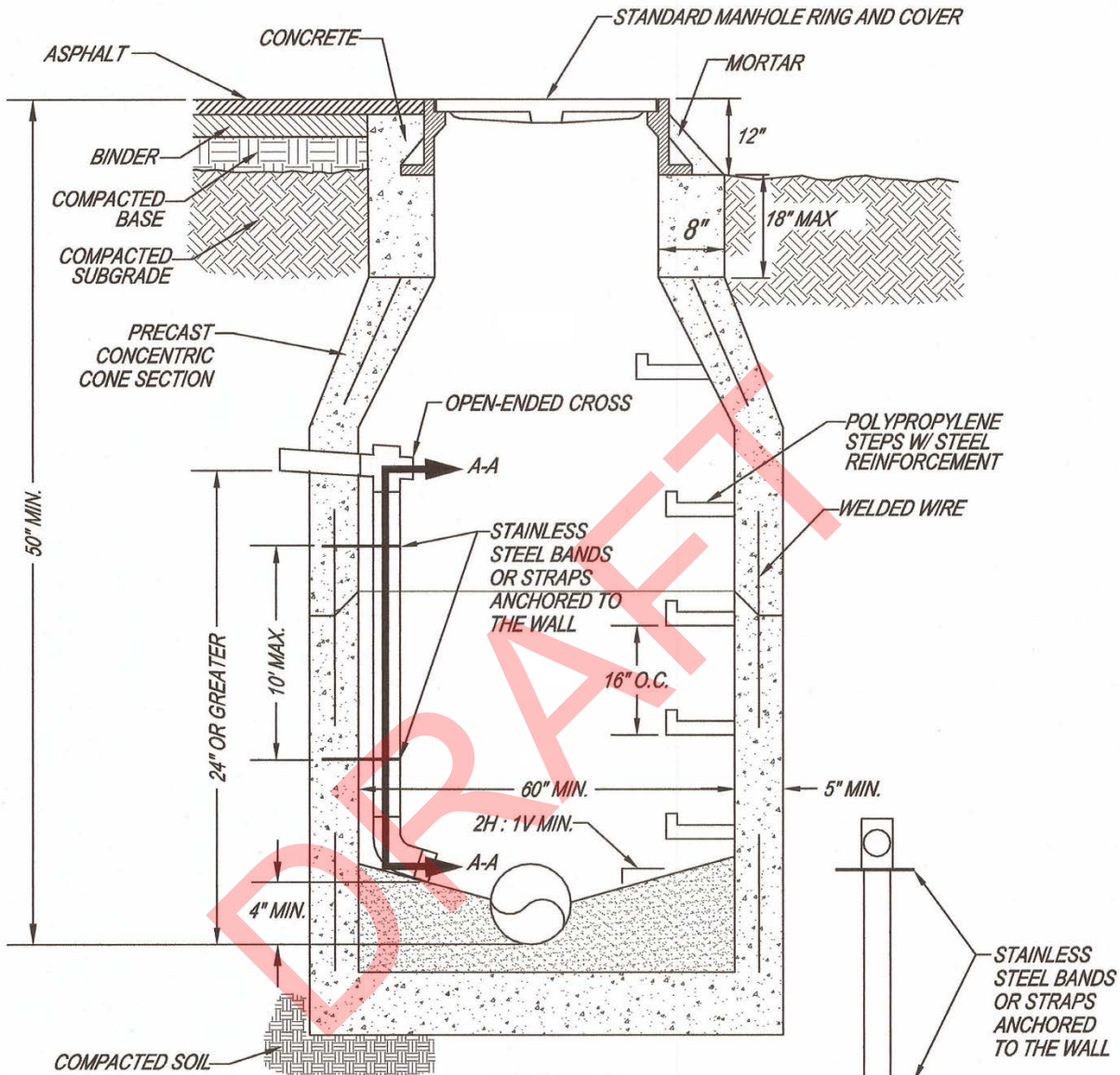

**PROFILE**

**SECTION A - A**

**NOTES:**

1. SERVICE LINES SHALL BE A MINIMUM OF FOUR (4) INCHES ABOVE THE INVERT OF THE MANHOLE OR FLOW LINE OF OUTGOING PIPE. SERVICE LINES ANGLED AGAINST THE DIRECTION OF FLOW SHALL BE A MINIMUM SIX (6) INCHES ABOVE THE FLOWLINE. IF THE ANGLE IS GREATER THAN 135 DEGREES, THE SERVICE LINE SHALL TIE TO THE MAIN.
2. ALL MANHOLES SHALL BE REQUIRED TO HAVE CLEAR LINE OF SIGHT FROM THE RIM TO ALL PIPE INVERTS IN THE MANHOLE.
3. ALL MANHOLE SECTIONS SHALL BE CYLINDRICAL SHAPED PRECAST STRUCTURAL CONCRETE.
4. ALL MANHOLES SHALL BE PROPERLY GROUTED AND WATER TIGHT.

DRAFT



DRAFT

MANHOLE ADJUSTMENT RISER

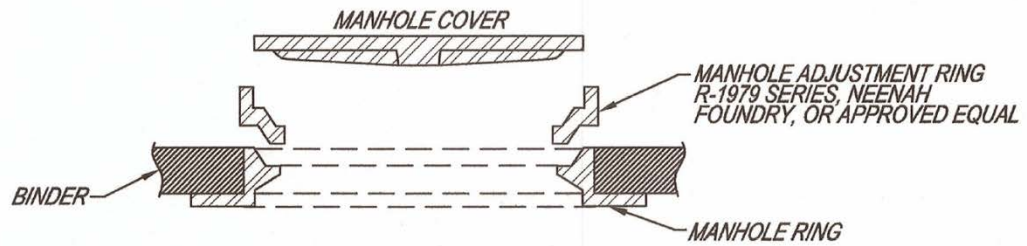

NOTES:

1. ONE PIECE CONSTRUCTION, NO WELDS. COATED TO PREVENT RUST.
2. MULTIPLE RISERS ARE NOT ALLOWED.
3. ALL MANHOLES IN PAVEMENT MUST BE FLUSH WITH THE BINDER LAYER. THE MANHOLE ADJUSTMENT RISER SHALL BE USED UPON PLACEMENT OF WEARING SURFACE.

DRAFT

DRAFT



**STANDARD MANHOLE**

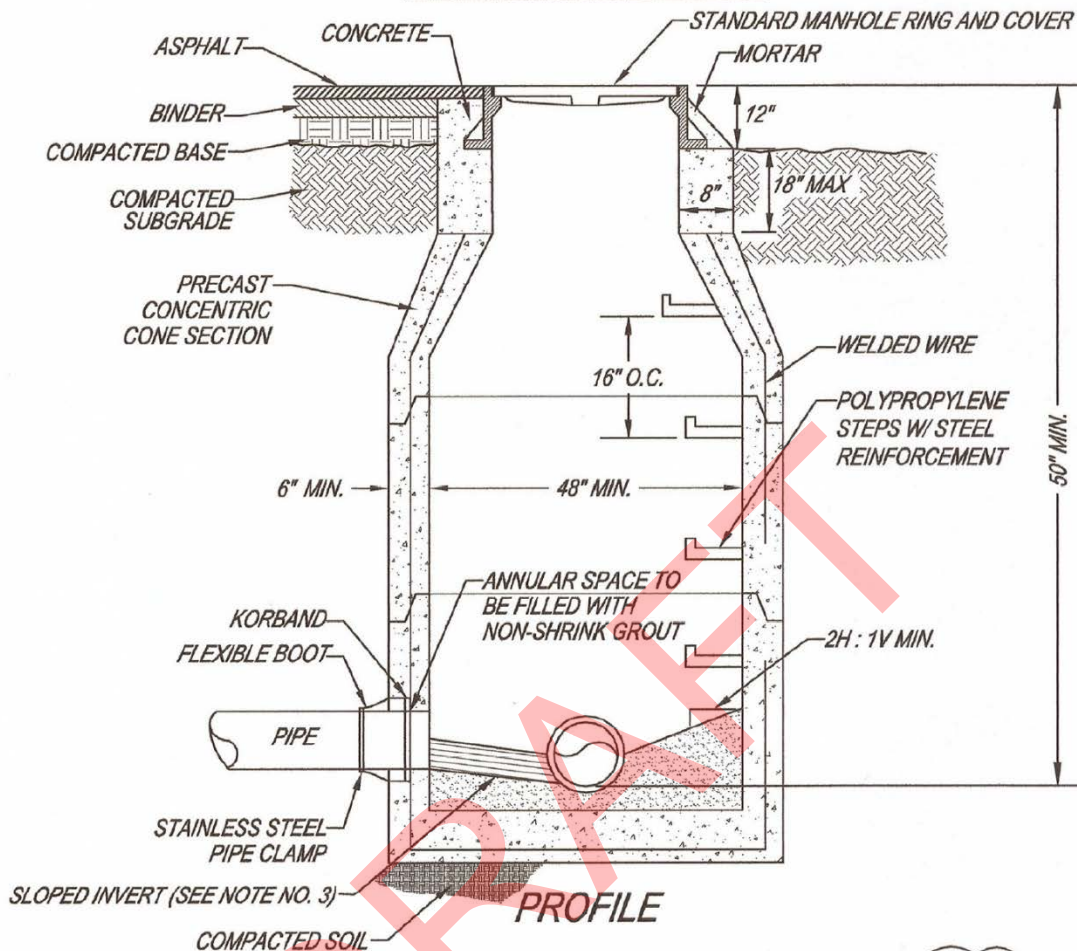

**PROFILE**

INVERT SHALL BE CONSTRUCTED OF SOLID CONCRETE AND SHALL CLOSELY APPROXIMATE THE SIZE, SHAPE, AND SMOOTHNESS OF THE SEWER PIPE.

**NOTES:**

1. ALL MANHOLES SHALL BE REQUIRED TO HAVE CLEAR LINE OF SIGHT FROM THE RIM TO ALL PIPE INVERTS.
2. ALL MANHOLE SECTIONS SHALL BE CYLINDRICAL SHAPED PRECAST STRUCTURAL CONCRETE.
3. ALL MANHOLES SHALL BE PROPERLY GROUTED AND WATER TIGHT.
4. INVERT SLOPE SHALL PROVIDE A 0.10' MIN. DROP ACROSS THE MANHOLE WHERE THERE IS NOT A TURN GREATER THAN 22 DEGREES AND A 0.25' MIN. DROP ACROSS THE MANHOLE WHERE THE TURN IS GREATER THAN 22 DEGREES.

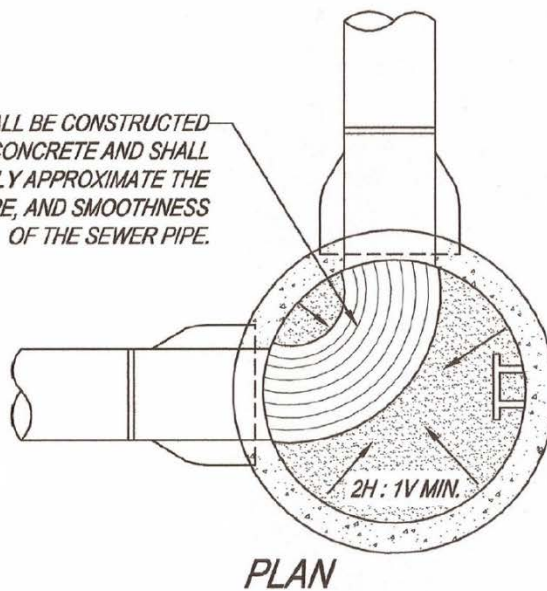

**PLAN**

DRAFT

TYPICAL OIL/GRIT SEPARATOR

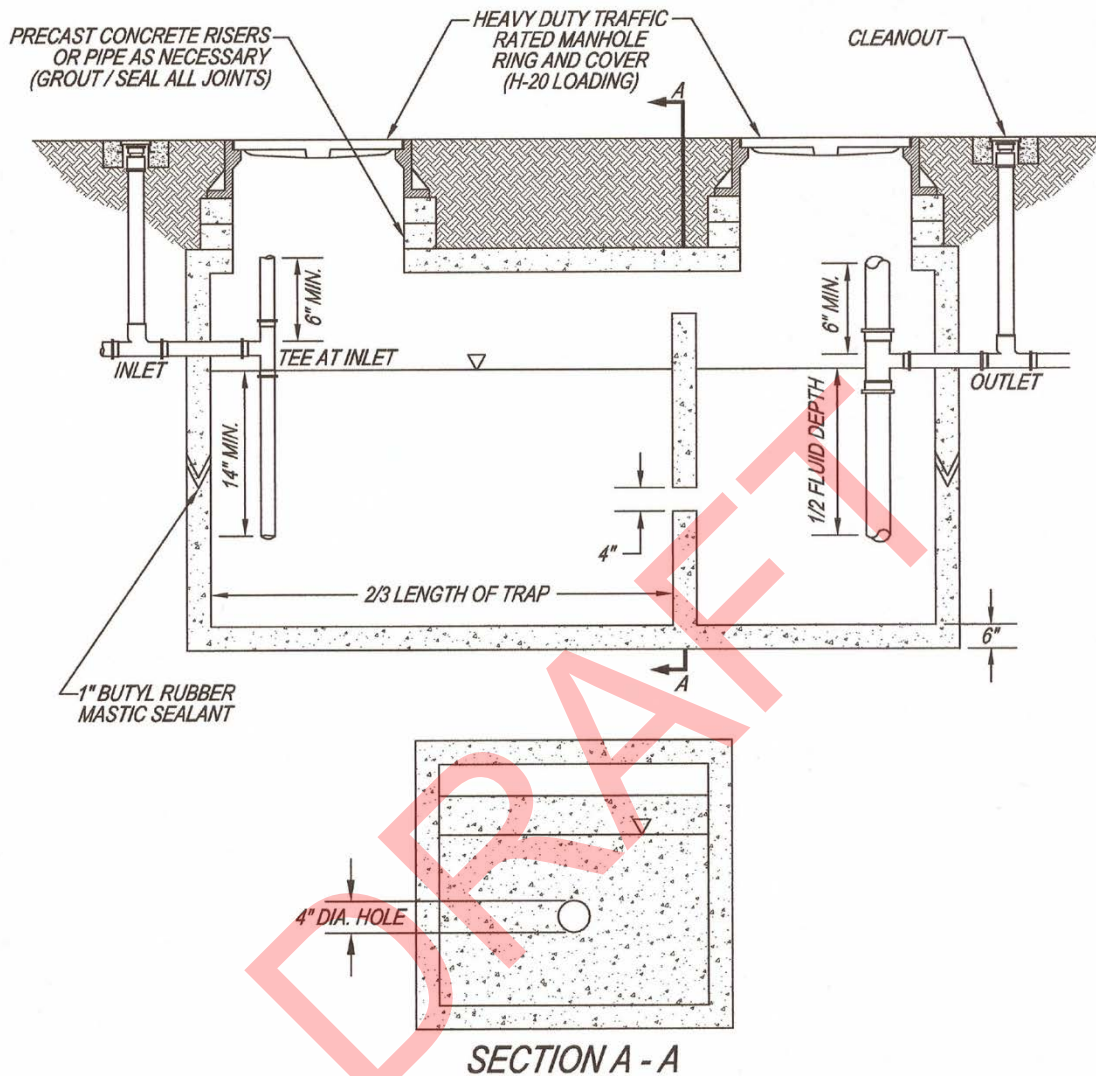

NOTES:

1. MANHOLE RING AND COVERS SHALL NOT BE COVERED, OR OBSCURED BY LANDSCAPING, PAVEMENT, ETC.
2. INLET AND OUTLET PIPES SHALL BE SCHEDULE 40 PVC, AND SHALL NOT BE COVERED OR CAPPED.
3. INLET PIPE MUST BE A MINIMUM OF 4" DIAMETER. VERTICAL PIPE ON OUTLET SIDE MUST BE A MINIMUM OF 6" IN DIAMETER.
4. SEPARATOR SHALL NOT BE LOCATED IN AN ENTRANCE, EXIT, DRIVE-THRU, OR UNDER A MENU BOARD.
5. MINIMUM SIZE: 1000 GALLONS.

DRAFT

PIPE ABANDONMENT AT MANHOLE

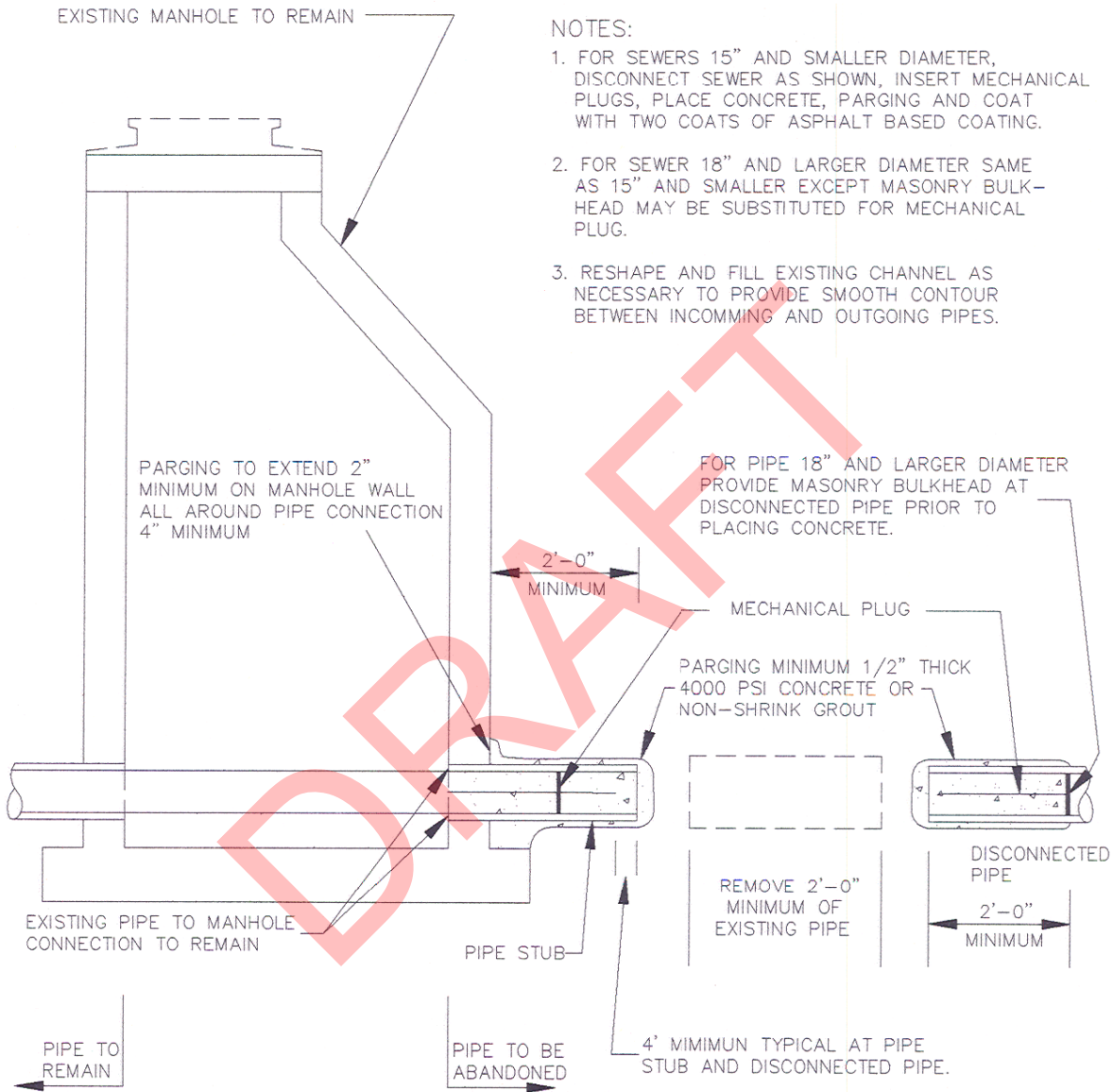

DRAFT



***BEDDING REQUIREMENTS FOR TRENCHES***

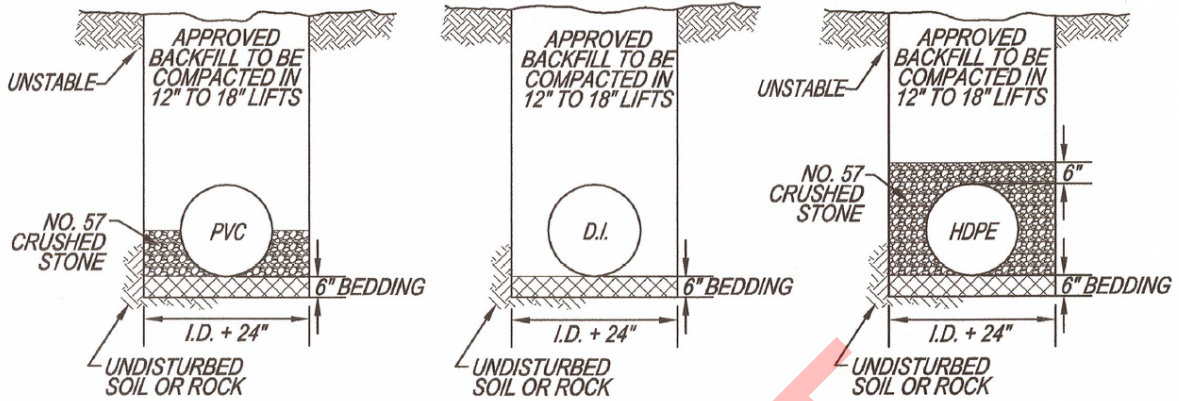

***NON-STREET TRENCH***

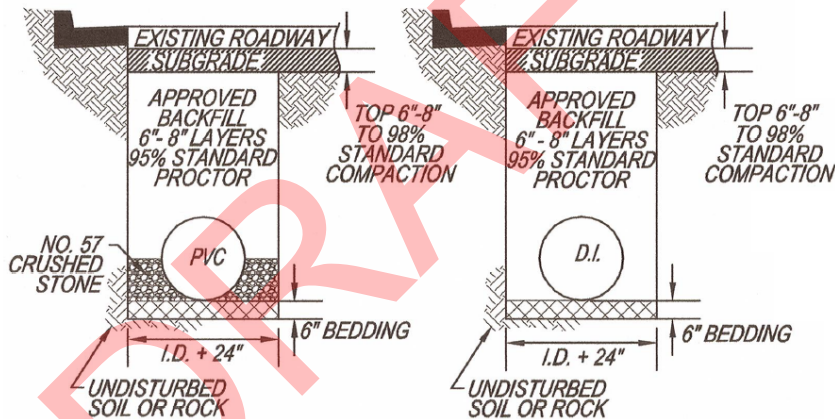

***STREET TRENCH***

***NOTES:***

1. BEDDING MATERIALS FOR PVC AND HDPE PIPE SHALL BE 1/4" TO 1 1/2" GRADED CRUSHED STONE SUCH AS: 56, 57, 6, 67, 68, 7, OR 78, STONE PER ALDOT STANDARD SPECS. SAND OR GRAVEL MAY BE USED AS BEDDING MATERIAL FOR D.I. PIPE.
2. WIDTH VARIES BASED ON WALL STABILITY. STABLE WALLS WIDTH AS NEEDED TO JOIN PIPE AND COMPACT HAUNCHING AND INITIAL BACKFILL. UNSTABLE WALLS: WIDTH TO BE A MINIMUM OF FIVE TIMES PIPE DIAMETER.
3. FLOWABLE FILL CAN BE USED AS BACKFILL, BUT MUST HAVE PRIOR APPROVAL AND MUST BE ALLOWED TO SETUP FOR 24 HOURS PRIOR TO TOPPING.
4. APPROVED BACKFILL MATERIAL INCLUDES 825 B, FLOWABLE FILL AND APPROVED DIRT. ALTERNATIVE MATERIAL MUST BE APPROVED BY PROJECT MANAGER PRIOR TO USE.
5. HDPE PIPE SHALL NOT BE USED IN ROADWAY.

DRAFT



TYPICAL SERVICE LINE

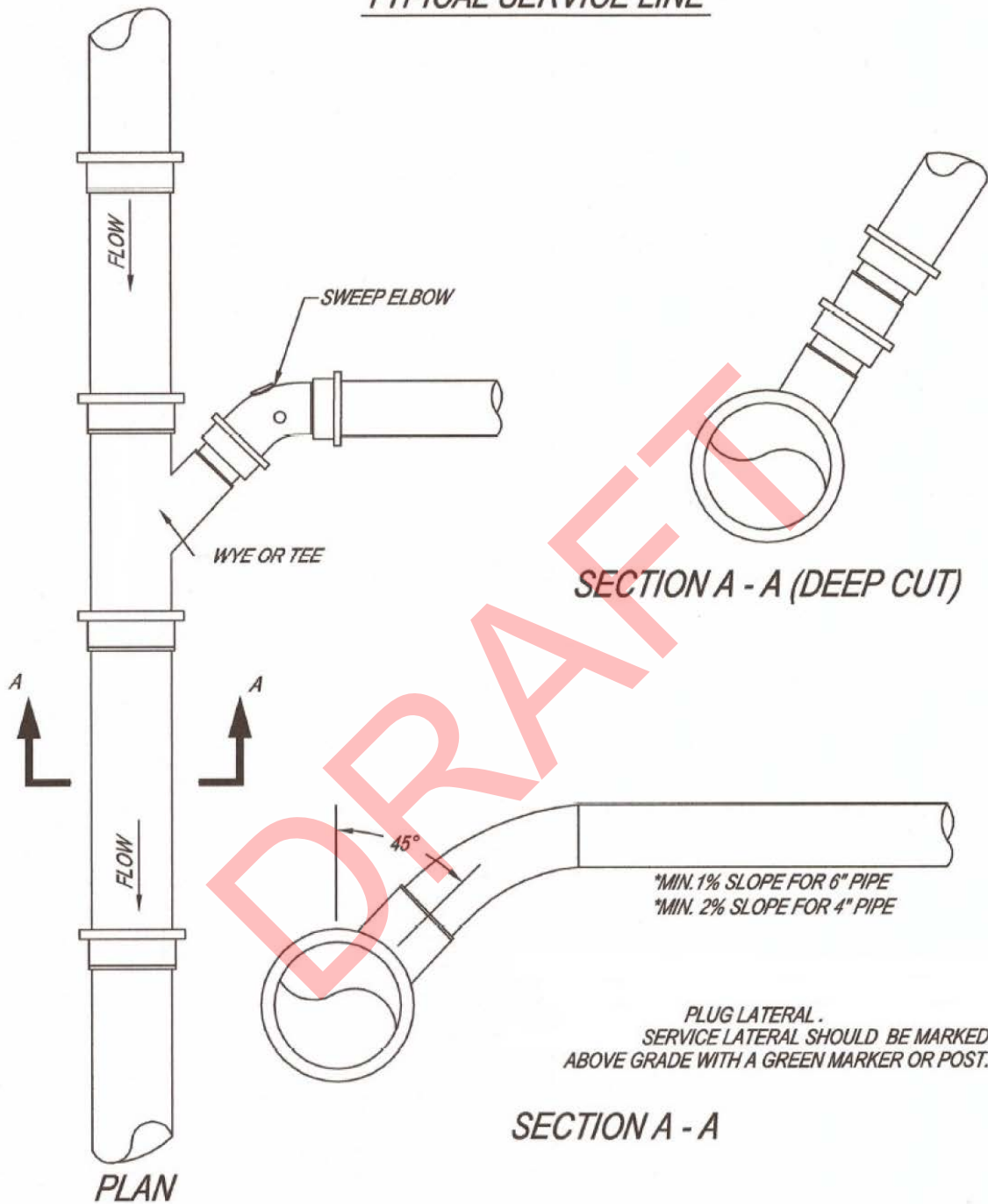

DRAFT

## 7.0 UTILITIES (POTABLE WATER AND SANITARY SEWER)

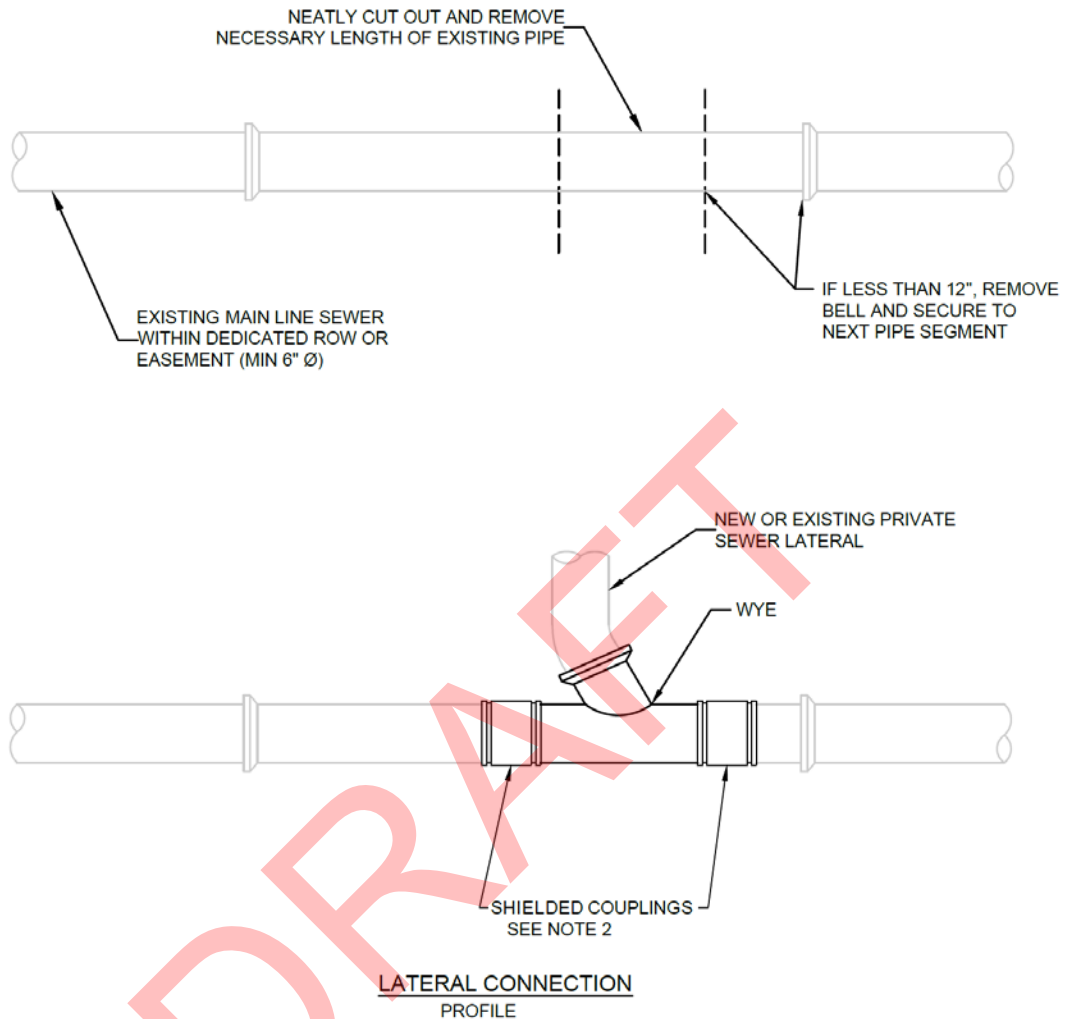

### NOTES

1. WHEN INSTALLING A NEW WYE ASSEMBLY TO AN EXISTING SEWER MAIN, THE MAIN SHALL BE INSPECTED BEFORE AND AFTER INSTALLATION AS DIRECTED BY PHENIX CITY UTILITIES.
2. SECURE ENDS WITH SHIELDED COUPLING WITH 316 STAINLESS STEEL COMPRESSION BANDS AND SHEER RINGS AS MANUFACTURED BY FERNCO JOINTS INC. OR APPROVED EQUAL. COUPLING TO BE MIN 6" WIDE.

DRAFT

TYPICAL AERIAL STREAM CROSSING

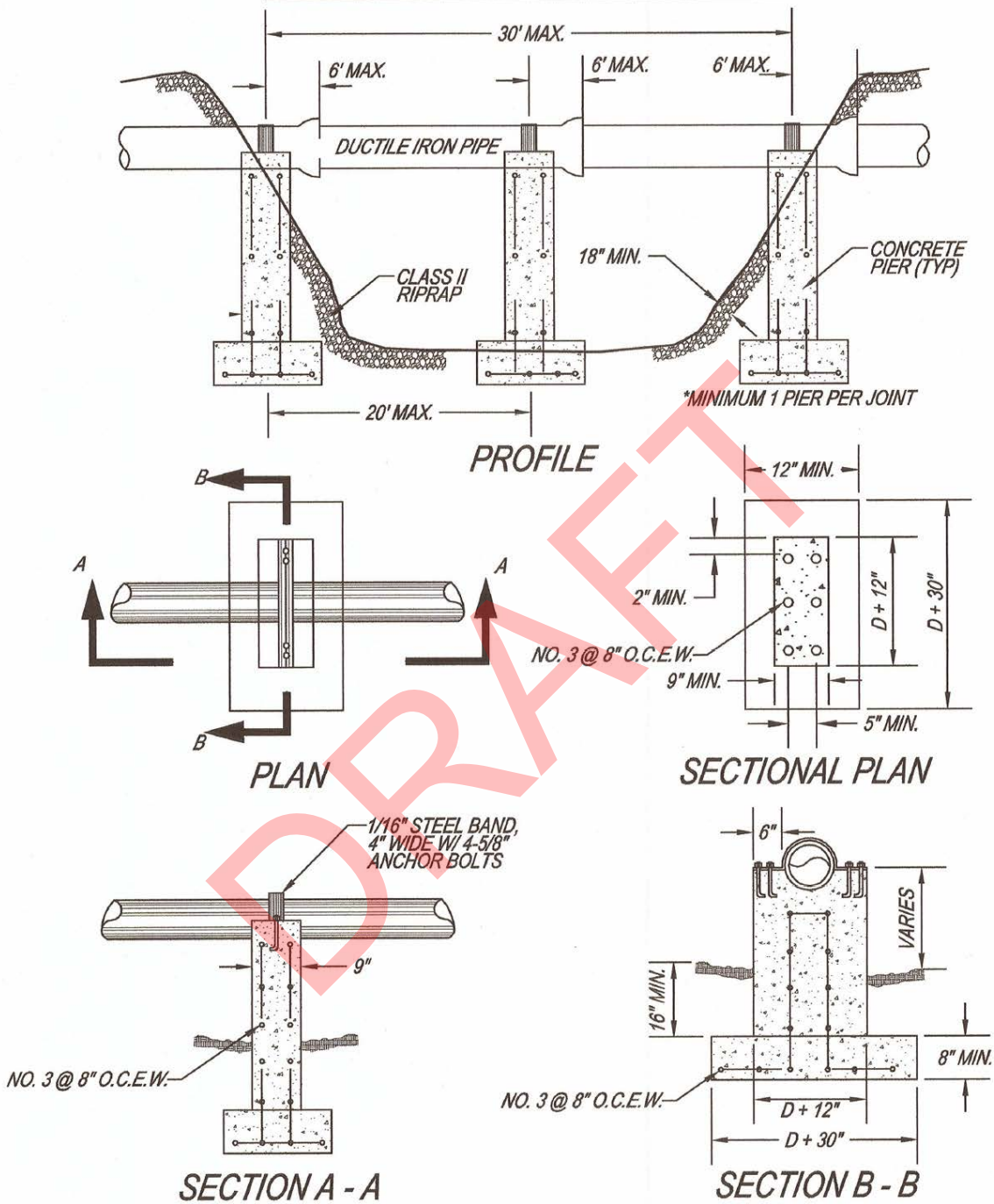

NOTES:

1. ALL CREEK CROSSINGS SHALL BE DUCTILE IRON, PRESSURE CLASS 350 PIPE.
2. FOUNDATION AND OR FOOTINGS FOR PIERS SHALL BE PLACED A MINIMUM OF TWO (2) FEET BELOW STREAM BED OR ANCHORED TO SOLID ROCK AND SHALL BE CERTIFIED BY A GEOTECHNICAL ENGINEER.
3. PIPE SHALL HAVE LOCKING GASKETS OR RESTRAINED JOINTS.

DRAFT

TYPICAL STREAM CROSSING

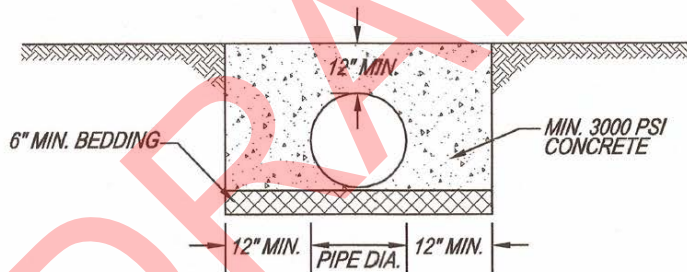
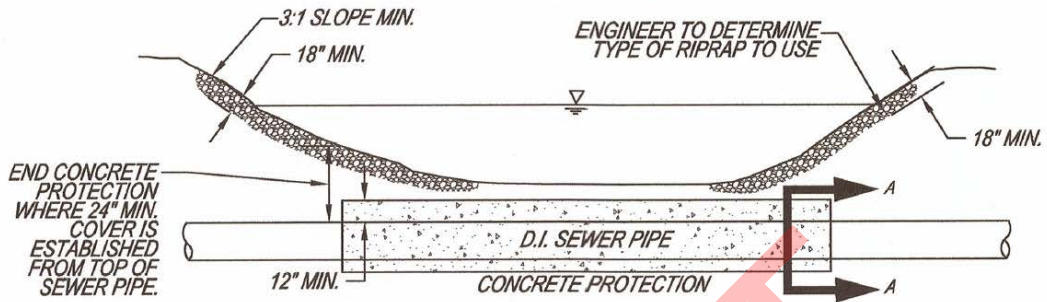

\*END CONCRETE PROTECTION WHERE 24" MIN. COVER IS ESTABLISHED FROM TOP OF SEWER PIPE.

**DETAIL SECTION A - A**

**NOTES:**

1. ALL CREEK CROSSINGS SHALL BE DUCTILE IRON, PRESSURE CLASS 350 PIPE.
2. PIPE SHALL HAVE LOCKING GASKETS OR RESTRAINED JOINTS WHERE LOCATED INSIDE STREAM BANKS.
3. END CONCRETE PROTECTION WHERE 24" MINIMUM COVER IS ESTABLISHED FROM THE TOP OF THE SEWER PIPE.

DRAFT



## 8.0 CONSTRUCTION

### 8.1 INTRODUCTION

The purpose of this section of the Manual is to provide construction and inspection procedures for infrastructure projects within Phenix City. Construction shall not begin without approved construction plans conforming to all applicable design standards in this Manual. Any changes in the design after plan approval must be submitted to the City Engineer. The City Engineer will distribute the plans to the appropriate departments for review and approval. If changes are required during construction, all work in the area of the changes shall cease until the plans have been revised, submitted, and approved.

### 8.2 CONSTRUCTION PROCESS

#### 8.2.1 Contacts

During construction activities, the Contractor's first point of contact for project related issues or questions shall be the assigned City inspector. This inspector is not authorized to make any changes to the issued construction plans or specifications. When further technical assistance or clarification is required, the inspector will contact the appropriate City department. Any direction received from the City authorizing changes in design or construction methods that vary from the approved plans shall be approved in writing. Verbal approval shall not be an acceptable authorization to deviate from the approved plans or standards. Changes in the approved design will typically require revisions to the plans to be submitted and approved.

Utility locate requests shall be submitted to Alabama One Call at 811 or 1-800-292-8525. All utility owners are not members of the One Call system. It is the Contractor's responsibility to ensure that all utilities are located. The Contractor shall contact the Phenix City Utilities Department Dispatch at 334-448-2902 to have Phenix City water and/or sanitary sewer located.

#### 8.2.2 Materials

Construction materials shall meet the requirements of the plans and specifications for each project. For items not specifically described in the project's specifications, the Contractor shall refer to ALDOT's Standard Specifications. The City may require detailed submittal information for any materials being installed. Materials that are not compliant with the specifications shall be removed and replaced at the Contractor's expense.

#### 8.2.3 Submittals

After approved plans have been issued and prior to construction, material submittal packages shall be provided to the City for review and approval. The packages shall

include all product specifications and material data sheets for public infrastructure to be installed during construction and to be owned and operated by the City. Submittal packages shall be provided to the City Engineering Department. Submittals shall not be provided for infrastructure to be owned and operated by other private or public owners or entities.

All material submittals shall clearly detail all necessary product information as applicable including, but not limited to: product ID, dimensions, type, material, construction, strength or rating, graphical schematic, picture or sketch, standard technical specifications, or any other attribute critical to the design and function of the material. Material submittals for concrete structures such as manholes, vaults, or wet wells shall clearly detail all dimensions, reinforcement, layout of affected appurtenances, hatch or cover specifications, and the associated fabrication manufacturer. Each material submittal package shall include a minimum of five full sets of all necessary material data sheets with a cover sheet detailing all included submittals and referencing the appropriate specification section to which the submittal applies.

The Contractor is responsible for reviewing submittals prior to transmission for approval and shall note any discrepancies between the submittals and the specifications. The Contractor is still responsible for providing materials which adhere to the project specifications even if discrepancies are not noted and inadvertently approved.

The City will review and approve, conditionally approve (as noted), or reject the material submittals for the proposed application in accordance with the requirements detailed in this Manual and the project's approved construction plans and specifications. The City will keep three copies of the material submittals and will return the remaining two copies to the Contractor. All rejected material submittals shall be resubmitted and approved prior to the start of construction. The City may opt to receive and review submittals in BlueBeam, or some other electronic format, in place of paper submittals.

### **8.2.4 Preconstruction Meeting**

Prior to beginning any work, the Contractor shall coordinate with the City to schedule a Preconstruction Meeting. Preconstruction Meetings are only required for Commercial/Residential Subdivisions as well as developments that involve new public infrastructure. Meetings for all other developments will be scheduled at the discretion of the City Engineer. If a meeting is required, the Contractor's Superintendent and Project Manager are required to attend. If requested by the City, the Contractor shall provide a schedule for the work at this meeting.

### **8.2.5 Installation Requirements**

Installation and construction shall follow the manufacturer's recommendations, the project's approved construction plans and specifications, and the City's specifications and requirements. Where a discrepancy exists between these documents, the more

stringent requirements shall apply. Where noted on certain equipment items, the City may require the manufacturer to certify the installation.

### **8.2.6 Inspection and Testing**

The City will assign an inspector to the project who will be responsible for inspecting the construction. The inspector shall be present for all pavement applications, water connections, sanitary sewer connections, storm sewer connections, and testing procedures. All testing procedures shall be coordinated with the inspector, and adequate notice of the testing schedule shall be given.

Certification of all tests is required prior to final acceptance of roadways as City streets.

### **8.2.7 Erosion Control**

The Contractor shall install and maintain all erosion control devices required by the contract documents, construction plans, or as directed by the City inspector. The Contractor shall employ a Qualified Credentialed Inspector (QCI) who is responsible for the proper installation and maintenance of the erosion control devices and who will make and document the inspections required by the Alabama Department of Environmental Management (ADEM).

### **8.2.8 Maintenance of Traffic**

A Traffic Control Plan shall be developed in conformance with the Manual on Uniform Traffic Control Devices Part 6, latest edition. Additional traffic control devices may be warranted based on actual physical conditions. These devices shall be installed in conformance with the MUTCD Part 6 as directed by the City Engineer.

Only devices or signs warranted during the current phase or section of construction shall be visible. All other devices or signs shall be removed, relocated, or covered if not in use.

Construction entrances shall be marked.

The Contractor shall coordinate with the City Engineer for traffic and/or work restrictions due to local policies. For work impacting State Routes, the Contractor shall coordinate with ALDOT for traffic and/or work restrictions due to state holidays, peak hour restrictions, etc.

### **8.2.9 Jobsite Safety**

It is solely the Contractor's responsibility to comply with all federal, state, and local laws, rules, and regulations regarding construction safety and health. The Contractor's attention is called to the guidelines established by the Occupational Safety and Health Administration (OSHA).

## 8.3 TRAFFIC SIGNAL CONSTRUCTION

A certified IMSA Level II Traffic Signal Technician shall have active involvement with all work required for the installation and operational testing of electrical materials and equipment (conduit, boxes, conductors, etc.). This Technician shall be onsite when any work is being performed. All installations shall comply with the regulations of the National Electrical Code and the National Electrical Safety Code, latest editions, and with the service rules of the electric service provider. In the case of a signal upgrade, existing equipment that is not placed back in operation shall be returned to the Phenix City Public Works Department (or to the Owner).

### 8.3.1 Materials Submittal

Equipment shop drawings and manuals must be submitted to the City for approval before materials are ordered. All materials furnished for use shall conform to the requirements given in the Alabama Standard Specifications for Highway Construction, latest edition. Unless the City has specific material requirements, the Contractor is directed to ALDOT's Qualified Products List (located on ALDOT's website under the Bureau of Materials and Tests) for material references.

Materials shall comply with requirements that may be given on the plans. Concrete for foundations shall comply with the requirements for Class B concrete as defined in ALDOT's Standard Specifications for Highway Construction (current edition), Section 501 (Structural Portland Cement Concrete). Reinforcing steel shall meet the requirements for Steel Reinforcement and shall be Grade 60 (400) billet steel. Minimum design wind speed shall be based on ALDOT standards. All materials and equipment furnished shall be new, except when the plans specifically provide for the re-use of existing equipment.

### 8.3.2 Testing

Before the installation of a traffic control system, the Contractor shall perform a pre-installation test. This test shall include the bench testing of all controllers, signals, detectors, etc. under signal load conditions for fourteen (14) consecutive days. The Contractor shall secure an acceptable site, approved by the City Engineer, for the bench test and shall perform all work required in the performance of the test. The Contractor shall notify the City Engineer a minimum of seven (7) days prior to the date that the test is to begin. The City Engineer shall be allowed to witness portions of the test if he/she wishes. None of the equipment shall be installed on the project until the bench test has been completed, the Contractor has submitted a letter to the City Engineer certifying that the equipment performed satisfactorily during the test, and the City Engineer has had sufficient time to review the letter. There will be no direct payment to the Contractor for the cost of the pre-installation test including the cost of a suitable test site and the setup of equipment for the test.

A complete 30 calendar day operational test of the new, or modified, traffic signal system shall be executed under normal traffic conditions. During the test period, the Contractor shall immediately address any inadequacies and shall have the system completely functional before leaving the project site at the end of any work day.

### **8.3.3 Inspection**

Some materials and equipment required to be furnished will be standard production type products. Acceptance shall be made by the City Engineer based on selected confirmation tests, the manufacturer's certification of the materials and equipment, and visual inspection at the job site. The manufacturer shall make test data and material samples from the production runs available to the City for use in evaluation of these items. Approved devices are shown on ALDOT's Approved Traffic Control Devices and Materials list which is part of the Qualified Products List located on ALDOT's website under the Bureau of Materials and Tests.

### **8.3.4 Closeout**

After all equipment has been installed and the operational check has been completed, the Contractor shall submit a set of plans showing in detail all changes to construction from the original plan details with special notation given to conduit location, elevation, and schematic circuit diagrams. This submittal shall be made both digitally and hard copy. Operation manuals and as-built wiring diagrams shall be furnished for all equipment and accessories required in the controller cabinet. These manuals and wiring diagrams shall be mounted to the cabinet in an appropriate manner.

## **8.4 ROADWAY CONSTRUCTION**

### **8.4.1 Clearing and Grubbing**

On new public roads, the right-of-way shall be graded to its full width. The right-of-way shall be cleared of all vegetation, trees, stumps, large rocks and other objectionable or unsuitable material prior to grading or filling unless otherwise approved, in writing, by the City Engineer.

### **8.4.2 Subgrade**

Prior to placing any base material on the subgrade, the Contractor shall have the subgrade material on grade, compacted, tested, and accepted by the City.

The City Engineer shall have the right to approve all borrow sources; however, this does not relieve the Developer and Contractor from full responsibility for the quality of material used.

In fill areas, the embankment material shall be installed in lifts no greater than 12". One (1) density test shall be taken for every 24" of fill for every 250' of roadway. The density

requirements for the embankment, up to 12" below subgrade, shall be 95% of Standard Proctor Density (ASTM D-698). Once the density passes, the next layer of fill can be installed. The density requirements for the top 12" of the embankment (the roadbed) shall be 98% Standard Proctor Density (ASTM D-698), and one (1) density test should be completed for every 250' of roadway. Once the density passes and the roadbed is accepted by the inspector, the Contractor can move forward with the next layer.

In cut areas, the material shall be cut to subgrade, compacted, and tested. The density requirements for the top 12" shall be 98% Standard Proctor Density (ASTM D-698), and one test should be completed every 250' of roadway.

Once the density tests for the subgrade have been accepted, the Contractor shall schedule a proof roll test with the City inspector. The Contractor shall provide a tandem dump truck with a driver to perform the proof roll test. The truck shall be loaded with at least 17 tons of material, and a weight ticket shall be provided to document the load. The truck driver shall slowly drive down one side of the road, turn around, and then slowly (no greater than 5 mph) drive down the other side of the road. The inspector will follow closely behind the truck to identify and mark (with pink paint) any areas of failure or areas that are questionable. A failure is defined as an area where the subgrade flexes, moves, or pumps under the weight of the tire. To proof roll a cul-de-sac, the truck driver shall drive around the perimeter of the cul-de-sac and then make three passes in the center to ensure that most of the area has been proof rolled.

If failures have been identified, the Contractor and the inspector shall discuss options to correct the failures. Once an option is agreed upon, the Contractor shall make the corrections, and the subgrade in the area of the failure shall be retested (density checked and proof rolled).

When all testing has been completed and is satisfactory to the City, the Contractor may proceed with the placement of the base material. The subgrade layer must remain free of ruts, ridges, and holes, and must remain true to grade until the next layer is placed. If a rain event occurs between the acceptance of the subgrade and the placement of the base material (crushed aggregate base), an additional proof roll will be required.

The Contractor should reference ALDOT's Standard Specifications for Highway Construction for additional QA/QC requirements for the subgrade.

### **8.4.3 Base**

Prior to placing any asphalt on the base layer, the Contractor shall have the base material on grade, compacted, tested, and accepted by the City. The Contractor shall install grade control, such as blue tops, to ensure that the grade and depth of the material installed meets the requirements of the contract documents and/or the

construction plans. The type of base material to be used and the required thickness will be identified in the approved contract documents and/or construction plans.

The base material (crushed aggregate base) shall be installed in one (1) layer up to a maximum of 6" compacted thickness. Layers greater than 6" shall be installed in equal layers not to exceed a maximum of 6" compacted thickness. The density requirements for the base material shall be 100% Standard Proctor Density (ASTM D-698) with one (1) test for every 250' of roadway.

Each base layer must have the required density and moisture at the time it is covered by another layer. However, maintenance requirements for moisture will be waived for a crushed aggregate base after the layer has been properly compacted with proper moisture content. Deficient base layers shall be corrected prior to the placement of the next overlying layer.

Where utilities are installed within the roadway, one (1) density test shall be performed for every 200 linear feet of utility line and one (1) density test shall be performed for every 2' of vertical fill.

Once the density tests for the base have been accepted, the Contractor shall schedule a proof roll test with the City inspector. The Contractor shall provide a tandem dump truck with a driver to perform the proof roll test. The truck shall be loaded with at least 17 tons of material, and a weight ticket shall be provided to document the load. The truck driver shall slowly drive down one side of the road, turn around, and then slowly drive down the other side of the road. The inspector will follow closely behind the truck to identify and mark (with pink paint) any areas of failure or areas that are questionable. A failure is defined as an area where the base flexes, moves, or pumps under the weight of the tire. To proof roll a cul-de-sac, the truck driver shall drive around the perimeter of the cul-de-sac and then make three passes in the center to ensure that most of the area has been proof rolled.

If failures have been identified by the inspector, the Contractor shall make the corrections and the base in the area of the failure shall be retested (density checked and proof rolled).

When all testing has been completed, and accepted by the City, the Contractor may proceed with the asphalt placement. The base layer must remain free from ruts, ridges, holes, and defects and must remain true to grade until the next layer is placed or the project is satisfactory. If a rain event occurs between acceptance of the base and the placement of the asphalt, an additional proof roll will be required.

The Contractor should reference ALDOT's Standard Specifications for Highway Construction for additional QA/QC requirements for the base.



#### **8.4.4 Asphalt**

The Contractor shall submit a pre-approved ALDOT mix design for each asphalt mix required for the project to the City for approval. No asphalt shall be placed until the corresponding mix design has been approved.

All underground utility lines shall pass their respective tests prior to placement of the asphalt binder layer.

At the City's discretion, samples shall be taken every 500 tons, or daily, and tested by an ALDOT approved materials lab acceptable to the Owner to confirm conformity with the approved design mix. The Contractor shall provide the City inspector with a letter noting the temperature delivery range for each mix. The inspector will check the temperature of the delivered asphalt to confirm that it falls in the designated range.

Each asphalt delivery ticket shall contain the approved mix design code. The ticket should also contain the job name and/or number. Tickets that do not contain the proper code/identification will be rejected. The inspector will verify that the ticket for each load is acceptable, and that the correct mix for the work item has been delivered prior to any of that load being placed. For City projects, the inspector will document all work for payment and shall be given all asphalt tickets for the project files and for determination of rates, pay quantities, etc.

##### **8.4.4.1 Patching**

The Contractor and the City inspector shall walk the street(s) designated for overlay and identify any base failures. The limits of areas that require patching shall be marked with pink paint.

The Contractor shall sawcut the limits of the required patch. The depth of the patch will be as shown on the drawings or as determined in the field. No material shall be removed until the depth of the patch is determined. Once the depth is determined and the material is removed, the inspector will visually inspect the material, ensure that all bad material has been removed, and make the necessary measurements for documentation.

Prior to placing any asphalt in the excavated patch area, the Contractor shall apply a tack coat to all edges of the existing asphalt to ensure a good bond with the new asphalt. Once the tack coat has been applied, the asphalt shall be installed and properly compacted. The maximum thickness of any installed layer shall not exceed 2". Where layer thickness exceeds this limitation, the asphalt shall be installed in 2 or more equal thickness compacted layers.

For City projects: Once the Contractor's invoice has been submitted, the inspector will verify the amount requested with his project records. If the totals



concur, the invoice will be forwarded on for processing. If totals do not concur, the Contractor and the inspector shall meet to determine the reason for the discrepancy. In the event that the Contractor and the inspector cannot reach an agreement, they will defer to the City Engineer whose ruling will be final.

### **8.4.4.2 Leveling**

The Contractor and the City inspector shall walk the street(s) designated for overlay and identify any areas that need to be leveled. The limits of areas that require leveling shall be marked with pink paint.

The Contractor shall clean the area to be leveled of all sand, dirt, debris, and loose material. Once the area is cleaned and acceptable to the inspector, the Contractor shall place tack coat at the rate established in the contract documents, the construction plans, or as designated by the inspector.

Once the tack coat is acceptably placed, the Contractor shall proceed with placing the asphalt leveling at the rates required to correct the profile or cross-slope. The asphalt shall be rolled to the satisfaction of the inspector. The inspector will perform a visual inspection to identify any obvious issues with the asphalt.

For City projects: Once the Contractor's invoice has been submitted, the inspector will verify the amount requested with his project records. If the totals concur, the invoice will be forwarded on for processing. If totals do not concur, the Contractor and the inspector shall meet to determine the reason for the discrepancy. In the event that the Contractor and the inspector cannot reach an agreement, they will defer to the City Engineer whose ruling will be final.

### **8.4.4.3 Milling**

Prior to beginning milling operations, streets that require milling will be inspected to determine the area(s) that require milling. The designated areas will be marked and measured by the City inspector. The inspector will record a variety of measurements to document existing conditions to develop a baseline for calculating quantities for payment. The inspector will also confirm the cross slope that is to be achieved after milling is complete.

During the milling operations, the inspector will visually inspect the street to confirm the milling depth and to make sure base material is not being exposed. The Contractor shall take care not to damage any manhole rings and covers or valve boxes. The Contractor shall adjust any manhole rings and/or valve boxes including adding a riser, when necessary, to make sure the tops of the manhole rings and valve boxes are flush with the new asphalt surface. Only one riser is allowed on a manhole or valve box. If one riser will not raise the cover to the

proper elevation, the Contractor shall excavate the manhole and/or valve box and adjust or replace the manhole ring and cover and/or valve box to bring the top of said manhole and/or valve box to the proper elevation.

Once the milling operation is complete, the Contractor shall clean the street of all debris including debris in the curb and gutter, in the inlets, and on any of the adjacent properties.

For City projects: Once the Contractor's invoice has been submitted, the inspector will verify the amount requested with his project records. If the totals concur, the invoice will be forwarded on for processing. If totals do not concur, the Contractor and the inspector shall meet to determine the reason for the discrepancy. In the event that the Contractor and the inspector cannot reach an agreement, they will defer to the City Engineer whose ruling will be final.

#### **8.4.4.4 Asphalt Overlays and New Pavement**

All required patching, leveling, and/or milling shall be complete prior to placing any asphalt on an existing road/street. On new roads/streets, the base material (crushed aggregate base) shall be complete, tested, and accepted prior to placing any asphalt (or tack coat if required). The City inspector and the Contractor will review and confirm the required rate of placement.

On new roads/streets, the contract documents and/or construction plans may require a prime coat on the base material. If a prime coat is required, it shall be applied as soon as possible after the base is accepted. The Contractor shall maintain traffic at an extreme minimum (preferably no traffic) until, in the opinion of the inspector, the prime coat is dry and cured. The Contractor shall not proceed with subsequent layers until the prime coat has been accepted by the inspector. The first layer of asphalt shall be installed as soon as possible after the prime coat (if required) has been installed and accepted.

For an overlay, the Contractor shall sweep the road/street clean to the satisfaction of the inspector. Once the cleanliness of the street is accepted, the required tack coat shall be applied at a uniform rate as established by the contract documents and/or construction plans.

After the inspector verifies the ticket and checks the temperature, the Contractor can begin placing the asphalt. Each load must undergo a ticket verification and temperature check. The inspector will continuously calculate the application rates and inform the Contractor if the rate is high or low so the rate can be adjusted accordingly.

After proper cooling time, the Contractor shall begin compaction of the asphalt

with a roller. The rolling patterns shall be such that the proper density is attained without over-rolling the asphalt. The Contractor shall confirm that all joints are properly compacted and rolled smooth. The inspector will verify that the joints are acceptable.

The inspector will perform a visual inspection of the asphalt to determine if any segregation has occurred. If segregation is evident, the inspector and the Contractor shall develop a plan for remediation.

For City projects: Once the Contractor's invoice has been submitted, the inspector will verify the amount requested with the project records. If the totals concur, the invoice will be forwarded on for processing. If totals do not concur, the Contractor and the inspector shall meet to determine the reason for the discrepancy. In the event that the Contractor and the inspector cannot reach an agreement, they will defer to the City Engineer whose ruling will be final.

### **8.4.5 Curb and Gutter**

The Contractor shall review the contract documents and/or construction plans to determine the type of curb and gutter required and the location. The City inspector will verify the type and location prior to installation.

The curb and gutter can be hand formed and poured or can be installed using a machine. Prior to the placement of any concrete, the Contractor shall have the proper forms for the chosen method installed with alignment and grade checked. As the curb and gutter is being installed, the Contractor shall determine the proper location of expansion joints. The curb and gutter shall have a smooth finish without any cracks.

Once the curb and gutter has been poured, the inspector will check the dimensions to verify that they meet the requirements of the contract documents and/or construction plans. Any curb and gutter that does not comply with the contract documents and/or construction plans shall be removed and replaced at the Contractor's expense.

If small cracks develop during the curing process, the inspector will identify those cracks. The Contractor shall saw cut the cracks and fill with an approved industrial caulk (from ALDOT's Materials, Sources and Devices with Special Acceptance Requirements Manual – Qualified Products List). Width and depth of the saw cuts shall be as recommended by the caulk manufacturer. If large cracks develop, those sections will need to be removed and replaced. The limits of the replacement shall be expansion joint to expansion joint unless different limits are approved by the inspector. The inspector will review the entire project for repairs or deformities and will notify the Contractor of any findings. The Contractor shall address these findings prior to acceptance.

## **8.5 DRIVEWAY CONSTRUCTION**

The Contractor shall apply for a driveway permit from the Building Department. After making the permit application, the Contractor shall formally request a site evaluation inspection for the proposed driveway. During this review, the inspector will confirm that the proposed location of the driveway meets the requirements of Section 4.0 of this Manual with regards to distance from intersections and conflicts with utilities. The inspector will also confirm that the proposed driveway will have a minimum of five (5) feet of horizontal separation from existing water and sanitary sewer services, including the flares at the curb, and the water and/or sanitary sewer piping under the curb. Once these conditions have been confirmed, the permit will be processed for approval and issued to the Contractor. After receiving the approved permit, the Contractor may begin construction.

After forming the driveway, the Contractor shall formally request a pre-poured forming inspection. Once the inspection has been completed, the Contractor will be notified that either all City requirements have been met and the driveway is approved or that corrections are needed. A reinspection of the driveway will be required if corrections are needed. Once the driveway has been approved, the Contractor may pour concrete in the form.

## 8.6 DRAINAGE CONSTRUCTION

Storm line installations, storm boxes, and curb inlets shall be inspected by the City's Engineering Department. The City encourages developments to incorporate LID practices as outlined in the Low Impact Development Handbook for the State of Alabama.

### 8.6.1 Storm Boxes and Curb Inlets

Installation of the storm boxes and curb inlets shall be in accordance with the lines and grades established as part of the approved construction plans and specifications. Three types of boxes are allowed based on the requirements of the construction plans: (1) poured-in-place, (2) precast, or (3) masonry.

The width and length of the excavation for the boxes and inlets shall be a minimum of 2' larger than the outside dimensions. The depth of the excavation shall be as required to meet the elevations shown on the construction plans. The boxes and inlets shall be installed on a suitable foundation. If, in the opinion of the City's inspector, the material in the bottom of the excavation is not suitable, it shall be removed and replaced with acceptable compacted material. The City's inspector will review and approve the excavation prior to installation of any inlet or box. All excavations shall meet the requirements of OSHA.

If the box/inlet is cast-in-place, the Contractor should refer to the details provided in the approved construction plans and specifications and construct the box/inlet accordingly.

The City's inspector will confirm the dimensions of the box/inlet, the placement of the steel, and the location/size of the holes for the pipe.

If the box/inlet is precast, the Contractor shall order the material in accordance with the details provided in the approved construction plans and specifications. Once the material is delivered, the Contractor shall verify that the material meets the project requirements. The City's inspector will confirm the dimensions of the box/inlet and the location/size of the holes for the pipe.

If the box/inlet is masonry, the Contractor should refer to the details provided in the approved construction plans and specifications and construct the box/inlet accordingly. The bricks shall be laid level with no more than ½" mortar joints. Mortar shall be plastered on the inside of the box/inlet to cover all exposed brick surfaces. The City's inspector will confirm the dimensions of the box/inlet and the location/size of the holes for the pipe.

For cast-in-place and mortar boxes/inlets: if at all possible, the storm piping should be installed to the proper line and grade prior to the construction of the box/inlet. For precast boxes/inlets: once the structure is installed, the storm piping should be installed to the proper line and grade and the annular space between the outside of the pipe and the box shall be sealed/waterproofed with a product from ALDOT's MSDSAR Manual.

Once the boxes/inlets and the storm piping are installed, backfill shall be installed around the structures and the piping and compacted in lifts not to exceed 12". For cast-in place and mortar boxes, backfill should not begin until the concrete/grout has cured for a minimum of 7 calendar days. In all cases, the backfill shall be brought up evenly around the perimeter of the structure. The City's inspector will approve the backfill prior to allowing the tops to be constructed.

Prior to beginning the construction of the tops, the Contractor shall remove all debris, grout, etc. from the interior of structures.

Once the backfill has been installed and accepted, the Contractor shall proceed with construction of the tops to the line and grade required by the approved construction plans. If required, the Contractor shall install a ring and cover, approved by the City, in the top. When forming is complete, the City's inspector will verify the size of the inlet tops and the placement of the steel.

When the box/inlet is complete, The City's inspector will verify that the construction meets the requirements of the approved construction plans and specifications.

At any point during the construction process, if the City inspector finds that the Contractor is not installing the box/inlet in accordance with the approved construction

plans, the inspector will immediately notify the Contractor of any concerns and make note of the concerns and the location on the Daily Field Report.

If the City's inspector finds that the construction of the box/inlet is acceptable, the inspector shall make note of the acceptance and the location on the Daily Field Report.

### **8.6.2 Storm Piping**

Installation of the storm piping shall be in accordance with the lines and grades established as part of the approved construction plans and specifications.

The Contractor shall review the construction plans and specifications and order storm piping of the size and material to conform with the job requirements. The City's inspector will confirm the piping size and material once delivered to the project.

The excavation for and installation of the storm piping shall begin at the outlet/downstream end and proceed upgrade. The trench width shall be sufficient to ensure room to properly and safely install the pipe and to place and compact the backfill material. The minimum trench width shall be the inside diameter of the pipe plus 24". In the case of multiple barrel runs, the clear span between pipes shall be a minimum of 12". If rock or any unsuitable material is encountered in the bottom of the excavation, it should be removed to a minimum depth of 12" and replaced with a material acceptable to the City's inspector.

The Contractor shall ensure that each joint is completely "belled-up" prior to installing the next joint. Prior to any backfilling, the City's inspector will review the installation for conformance with the approved construction plans and specifications and take pictures of each joint.

#### **8.6.2.1 Reinforced Concrete Pipe (RCP)**

Each joint shall be grouted watertight, and each lifting hole shall be grouted or plugged with an acceptable manufacturer supplied plug. The pipe shall be laid true to grade with no deflection. The gap at each joint shall be consistent for the entire circumference. No backfill shall begin until the grout has cured.

The pipe shall be installed on a minimum of 6" of #57/#67 stone bedding material. The #57/#67 stone shall be brought up to the spring line of the pipe, evenly compacted in 6" lifts.

In trenches not in streets, an approved backfill material shall be installed from the spring line of the pipe to the top of the trench, compacted in 12" to 18" lifts. Approved backfill material includes 825B crushed stone, flowable fill, or dirt approved for use.

In trenches in streets, an approved backfill material shall be installed from the spring line of the pipe to the subgrade of the street, compacted in 6" to 8" lifts and tested. Density shall be a minimum of 95% standard proctor. The top 6" to 8" of the backfill (subgrade) shall be tested, and density shall be a minimum of 98% standard proctor. Approved backfill material includes 825B crushed stone, flowable fill, or dirt approved for use.

The City's inspector shall witness the backfill, particularly under streets, and shall review the density tests to ensure the compaction meets or exceeds the project requirements.

If the City's inspector deems that the installation does not meet the project requirements, the inspector will immediately notify the Contractor of the deficiencies and note the deficiencies in the Daily Field Report along with the location.

If the City's inspector deems that the installation meets the project requirements, the inspector will note such approval in the Daily Field Report.

### **8.6.2.2 High Density Polyethylene (HDPE) Pipe**

The manufacturing and installation of the HDPE pipe shall meet the requirements of ASTM-F2306, ASTM-D2321, ASTM-D2412, and ASTM-D3350.

The pipe shall be installed so that the joint will form a continuous line, free from irregularities in the flow line. The inside diameter of the pipe shall not be reduced by more than 7.5% of the base inside diameter when measured or visually inspected not less than 30 days after completion of the installation.

If the City's inspector deems it necessary, the Contractor shall perform a go/no-go mandrel test on a minimum of 10% of the pipe installed for pipes up to 36" diameter. The Contractor shall provide a 92.5% mandrel for the test. For pipes greater than 36", the deflection will be determined by manual measurements. If any of the deflection tests fail, the Contractor shall replace the pipe at no extra charge to the owner.

The pipe shall be installed on a minimum of 6" of #57/#67 bedding material, loosely compacted.

In trenches not in streets, the #57/#67 stone shall extend to 6" above the top of the pipe, installed in 6" maximum compacted layers (95% standard proctor). The remainder of the trench shall be backfilled with an approved backfill material. Approved backfill material includes 825B crushed stone, flowable fill, for dirt approved for use.

The City's inspector shall witness the backfill and shall review the density tests to ensure the compaction meets or exceeds the project requirements.

If the City's inspector deems that the installation does not meet the project requirements, the inspector will immediately notify the Contractor of the deficiencies and note the deficiencies in the Daily Field Report along with the location.

If the City's inspector deems that the installation meets the project requirements, the inspector will note such approval in the Daily Field Report.

HDPE pipe shall not be used in streets.

### **8.6.2.3 Side-Drain/Driveway Pipe**

All side-drain and/or driveway pipes require concrete headwalls. The Contractor shall refer to the approved construction plans and specifications, if applicable, for details. The City's inspector will review the concrete headwall for acceptability.

## **8.7 UTILITY CONSTRUCTION**

### **8.7.1 Water**

The installation of all potable water lines shall be subject to inspections by the City's Engineering and Utility Department personnel.

Upon successful installation of potable water lines, including all piping, fittings, valves, fire hydrants, and service piping up to and including the meters, the Contractor shall contact the City to schedule a pressure test on the completed line or line segment. The Contractor must provide all necessary equipment to perform the required hydrostatic pressure test and record the results. Successful results shall be turned over to the City. The test must run for two hours with no more than a 5 psi pressure loss. The test fails if more than 5 psi are lost. The Contractor must reschedule another test if failing results are received. All pressure tests shall be completed in the presence of a City representative.

After a successful pressure test on the potable water line, all potable water components shall be flushed to remove dirt and debris, chlorinated with an elevated concentration of chlorine solution (at least 50 ppm), and allowed to sit for 24 hours. Next, the potable water line shall be flushed until the chlorine residual is acceptable for human consumption. This process shall be followed by the collection of samples for bacteriological testing. Chlorination and testing of the potable water line shall be



repeated as necessary until a clear fecal coliform sample is obtained. All chlorination and sampling shall be completed in the presence of a City representative.

Additional information regarding the required construction materials and installation requirements may be found in the most current version of the City's Water Distribution Specifications (see Appendix 7A) and the City's standard details for water line construction (see Appendix 7B). All pressure charts indicating passing pressure tests and results indicating a clear coliform sample from an approved laboratory (certified by the EPA and the State to analyze drinking water) shall be submitted to the City with the project closeout documents.

### **8.7.2 Sanitary Sewer**

During installation of the sanitary sewer infrastructure, the City inspector will perform a visual inspection of the installed material. Any issues noted with the material or installation procedure shall be immediately corrected by the Contractor at no cost to the City.

Upon completion of the installation process, the gravity sanitary sewer, the sanitary sewer manholes, the sewer force mains, and the sanitary sewer pump/lift stations shall undergo the appropriate testing. The City shall be contacted to schedule the testing.

#### **8.7.2.1 Gravity Sanitary Sewer**

Upon completion of the installation, all lines shall be flushed (jetted) clean to remove all dirt and debris. The Contractor shall furnish all equipment, material, and personnel necessary to perform the required low pressure air test on each segment of the gravity sewer as required by the City's Sanitary Sewer Specifications (see Appendix 7C). At the City's option, the Contractor may be required to perform a mandrel test on certain pipe segments if the visual inspections yield potential problems.

#### **8.7.2.2 Sanitary Sewer Manholes**

At the City's option, the Contractor may be required to vacuum test some or all of the manholes if visual inspections yield potential deficiencies. The Contractor shall furnish all equipment, material, and personnel necessary to perform the required vacuum test as required by the City's Sanitary Sewer Specifications (see Appendix 7C).

#### **8.7.2.3 Sewer Force Mains**

Upon completion of the installation of the force main piping, the line or line segments shall undergo a hydrostatic pressure test as required by the City's Sanitary Sewer Specifications (see Appendix 7C). The Contractor shall furnish all

equipment, material, and personnel necessary to perform the testing and record the results. The results shall be turned over to the City.

### **8.7.2.4 Sanitary Sewer Pump/Lift Stations**

Upon completion of the installation of the pump station and all appurtenances, the station will undergo a final inspection. The final inspection is to be coordinated through the City's Utilities Department. Required attendees are the Contractor, the electrical contractor, the project engineer(s), and the pumping equipment supplier/manufacturer. The Contractor shall supply all the necessary equipment, material, and personnel to subject the pump station and all equipment to all possible pumping scenarios as required by the City's Sanitary Sewer Specifications (see Appendix 7C). Upon final acceptance, the Contractor shall deliver all required O&M manuals, warranties, as-built drawings, and spare parts to the City.

### **8.7.2.5 Closed Circuit Television (CCTV) Inspection**

After a successful pressure test, but prior to acceptance, all sanitary sewer lines shall be inspected via closed circuit television (CCTV) by the City's Utility Department or the Developer if the City's is unable to televise the sanitary sewer. The Contractor shall notify the City's Engineering Department in writing that the sanitary sewer is complete and ready for CCTV inspection as required by the City's Sanitary Sewer Specifications (see Appendix 7C). Deficiencies found during the CCTV inspection of sanitary sewers shall be corrected by the Contractor and reinspected until all deficiencies have been corrected. If the City's CCTV system and staffing are available, the City will perform the CCTV inspections for the Developer at the Developer's expense based on the current fees/cost of the Phenix City Utilities Department.

## **References**

*Manual on Uniform Traffic Control Devices*, U.S. Department of Transportation, Federal Highway Administration (2009)

*ALDOT Standard Specifications for Highway Construction* (2018)

*National Electrical Code*, National Fire Protection Association (2020)

*National Electrical Safety Code*, Institute of Electrical and Electronics Engineers (2017)

*Low Impact Development Handbook for the State of Alabama*, Alabama Department of Environmental Management, Alabama Cooperative Extension System, and Auburn University

*ALDOT Materials, Sources and Devices with Special Acceptance Requirements Manual (Qualified Products List)* (Latest Edition)

*Phenix City's Water Distribution Specifications* (March 2018)

*Phenix City's Sanitary Sewer Specifications* (March 2018)

*Occupational Safety and Health Administration (OSHA) Regulations, Part 1926 – Safety and Health Regulations for Construction* (Latest Edition)

DRAFT